

More Than a Toy—But Just As Much Fun!



8 Electronic Learning Machine
37⁹⁹

Over 250 Learning Activities

2 extra card sets available



9 22⁴⁹

Quiz Wiz comes with "1,001" question/answer cartridge

SAVE \$1 when you buy any 2 extra cartridge/quiz booklet kits together

9 extra kits available including "Guinness Book of World Records," "People's Almanac," "Math Mania"



10 59⁸⁸

"Please spell kitten... that's correct; now spell pounce"

Speak & Spell
Now you can expand its vocabulary—

3 extra modules available



11

Melody Madness
29⁹⁹

- Play musical matching games
- Compose and play music

SAVE THIS CATALOG. Order anything from pages 375-527 until August 15, 1981



12 "Little Professor"
12⁹⁷



13 Spelling B
33⁸⁸



14 Mr. Challenger
33⁸⁸

Quiz Kid Math
977

He winks green for right answers—red for wrong!



15

Computer Mathematician
33⁹⁹



16

Quiz Kid® Speller
17⁸⁸



17

and Skill



Wish Book value

Cut \$1.00

Casino-style Dice Layout

Last Christmas was \$17.95 **\$16⁹⁵**



8

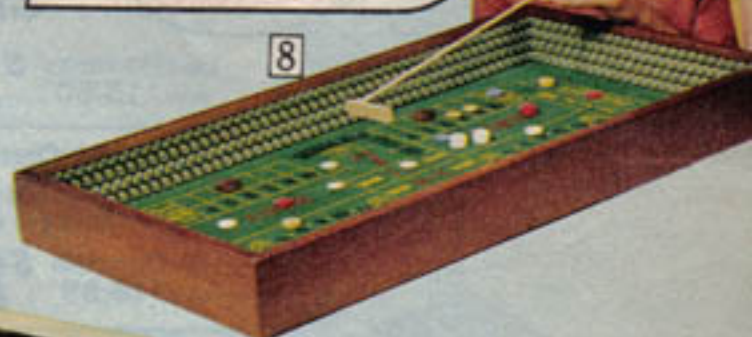

7
Pachinko
Pinball Machine
\$46⁸⁸



9
Electro Draw Poker
\$3⁵⁹
without battery



10
Table Model
Draw Poker
\$6⁶⁶
without batteries



11
Mini Electro
Slot Machine
\$16⁵⁰
without batteries

Wish Book value **Cut \$4.00**

Super Electro
Slot Machine
\$34⁵⁰
without batteries



12



13
Space Tilt
\$9⁹⁹

Wish Book value
Save \$21.40
\$29⁵⁰



Computatic®
Football/basketball
with hockey/baseball overlay

14

Wish Book value
Cut \$2
Skiddles
\$16⁹⁹

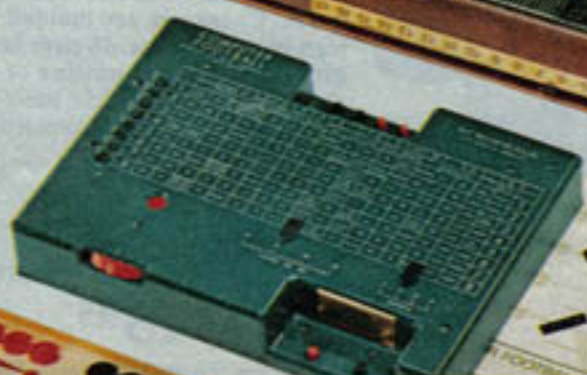

Wish Book value
Our lowest
price ever for a
Computerized
Football Game
\$9⁹⁹



18
Backgammon Set
with guide book
by Prince Obolenski
\$7⁵⁰



19
Space
Probe
\$5⁹⁹



17
Tri-Tac-Toe
\$6⁸⁹

Do you believe in lucky stars?

Believe in 'em or not, the new Zodiac™ Astrology Computer offers astral advice using modern electronics

With this fascinating electronic "brain" and the Zodiac™ Manual edited by world famous astrologer Sidney Omarr, you can chart horoscopes for anyone simply by knowing his or her birthdate, time and place

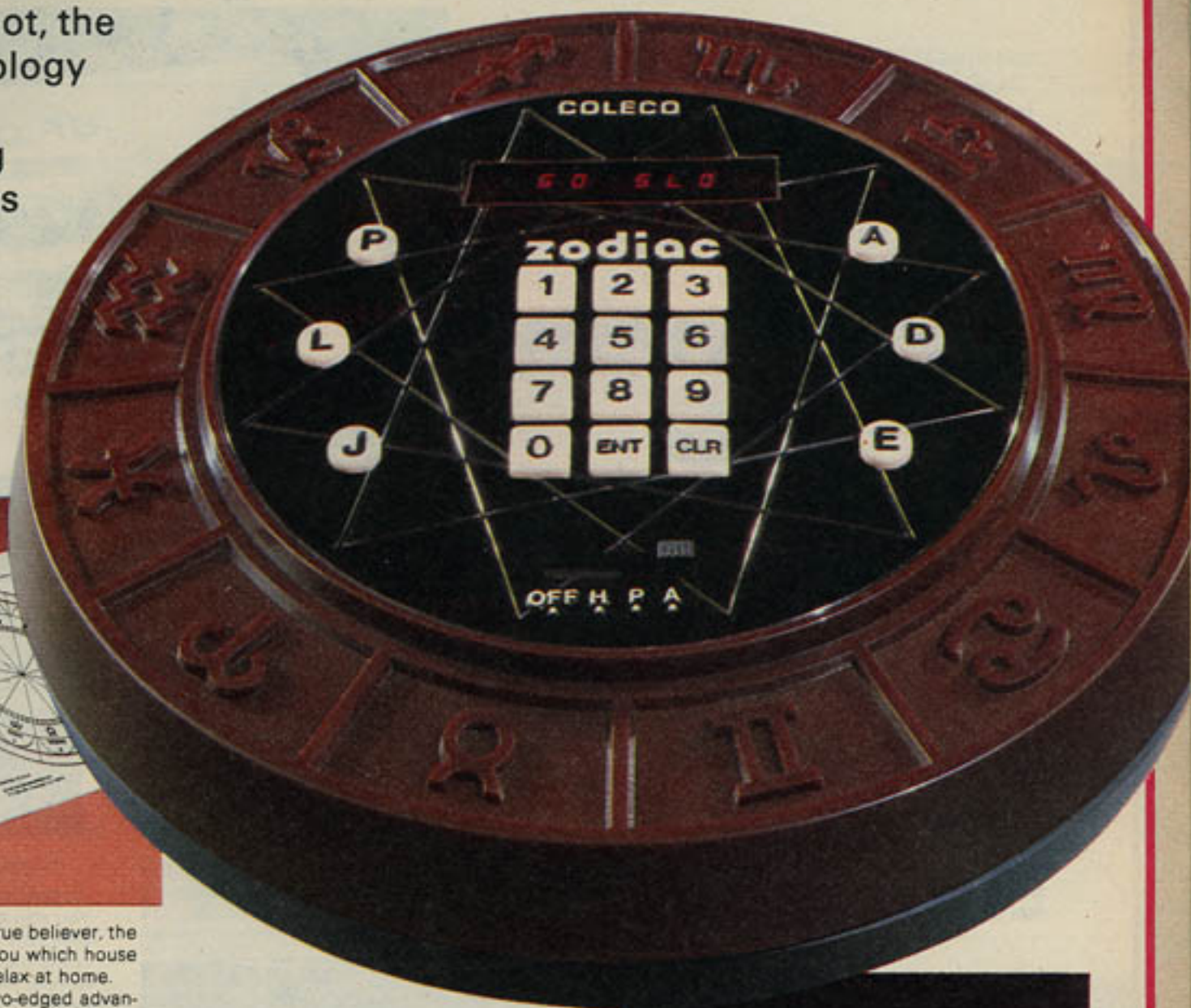

Whether you're a curious skeptic or a true believer, the Zodiac™ Astrology Computer can tell you which house your stars are moving into while you relax at home.

This electronic star gazer offers a two-edged advantage over other methods of determining your horoscope. It provides a "reading" that's far more personalized than horoscopes in the newspaper because you enter your own (or a friend's) day, time and place of birth into the computer's brain. And you won't have to travel to a professional astrologer for a daily survey of the comings and goings of cosmic influences.

INTRODUCING ZODIAC

Zodiac™. The Astrology Computer, is just the thing for people who believe that their lives are influenced by the stars. When used in conjunction with the Zodiac™ Manual, Zodiac™ can help you learn more about yourself, your friends, your past and your future.

ZODIAC™ MANUAL

The Zodiac™ Manual is a complete instruction and source book for Zodiac™. The Astrology Computer. The editor is well-known astrologer Sidney Omarr who is featured on his own radio program and in his daily astrology column which is published in newspapers throughout the world.



WHAT ZODIAC™ CAN DO FOR YOU

The Zodiac™ computer, when used with the Zodiac™ Manual, can furnish you with three different types of star-struck information.

In the Horoscope Mode, you can get a computer readout of the planetary positions at the time of your birth and a list of corresponding personality characteristics. With this information, plus the additional data found in the manual, you can chart anyone's horoscope simply by knowing the date, time and place of his or her birth.

In the Daily Preview Mode, Zodiac™ can clue you in to how the stars appear for any day you have in mind—past, present or future.

In the Advice Mode, the Zodiac™ computer can offer its opinion about some of the many questions you ask yourself each day: "Should I travel today?", "Is this a good time to start saving money or to spend it?", "Should I see my former boyfriend tonight?"

IT'S SIMPLE TO GET YOUR EXACT HOROSCOPE

As sophisticated as the computer sounds, the Zodiac™ is simple to use. To chart a horoscope, look in the manual to find the proper codes for the date and place of your birth and enter them in the computer. Next, punch in the time of your birth. Then, watch the lights and listen to the electronic sounds as Zodiac™ goes to work.

Code numbers will appear on the digital readout. Copy these down on the horoscope form provided and then match them up with the personality characteristics and assessments listed in the manual. It's that easy.

It's just as simple to get a daily preview or the computer's answer to a question. Just follow the directions in the manual.



Want to dig deeper? The Zodiac™ Manual can tell you how to work out more detailed astrological information.

Plastic unit measures 7x2 inches high. Manual and astrological charts included.

ORDERING INFORMATION: Uses two 9-volt alkaline batteries or AC adapter (not included).

3 C 2851—Shipping weight 1 lb. \$44.99

CHRISTMAS is for Children
FAMILY GAME CENTER

MAGNAVOX



G

- Pure, perfect sound—straight from the recording studio!
- No disc wear, no stylus to replace... ever!
- "Memory" remembers up to 15 tracks!
- Easier to operate than your turntable!

H

299.99 No money down
\$17 a month*

Magnavox audio disc player

G Magnavox compact digital laser beam disc player. Imagine no static, no cracking, no skipping—just pure sound, so close to a "live" performance. Unique single laser reads sound signals off the 4¼-inch discs. Signal is deciphered electronically to produce a pure audio signal with virtually no "wow" and "flutter". Its dynamic range is far greater than the 50 dB-range of conventional stereos. Channels are distinct since each one is digitally recorded. And it's so easy to use! Just insert disc and touch a button! Automatic cueing "Go To" takes you to your desired track. "Search" button locates a particular passage within a track. "Repeat" repeats the same track. "Pause" stops disc instantly; press again and music resumes exactly where it stopped. "Memory" lets you program up to 15 tracks—ready for recall. Connects to any sound system. 3 in. high x 12½ in. wide x 10½ in. deep. UL listed. Write for free copy of Mfr.'s Warranty, see page 497.
63 G 6760 MS—Ship. wt. 13 lbs. 299.99

H Start your disc collection here: Wt. 1 lb. ea.

Title	Catalog no.	Each
Thriller (Michael Jackson)	62 G 51101 LS	19.95
Eyes That See (Kenny Rogers)	62 G 51100 LS	19.95
Always On My Mind (W. Nelson)	62 G 51102 LS	19.95
Hooked On Classics	62 G 51103 LS	19.95
Chariots Of Fire (Vangelis)	62 G 51104 LS	19.95

*Montgomery Ward Credit customers:
This purchase may change your monthly payments depending on the highest balance on your account. Does not apply to AZ, NM and OR residents. See pg. 497.



E

F



Save \$15

Our lowest-priced scientific calculator with advanced features

29.98

- For students, architects, engineers—a truly professional instrument loaded with features
- A total of 69 pre-programmed functions
- 12-digit L.E.D. display in scientific notation
- 3 separate addressable accumulating memories
- 8 important metric conversions including lb./kg, inches/cm, US gallons/litres, °F/°C

A 10-digit mantissa, 2-digit exponent; 2 levels of parentheses; trig functions and their inverses, log functions. Degree/radian/grad and degree/minute/second conversions, polar/rectangular coordinates. Statistical summations, mean and standard deviation, factorial. Uses rechargeable batteries (batteries and recharger included). With full operating instructions. Carry case. High-impact plastic housing; abt. 6 1/4 x 3 1/4 x 1 1/4", weighs about 1 lb.

032 541 537—Regularly 44.98, Each 29.98

Save \$5 L.C.D. scientific

- Constant memory retains data even when unit is turned off, cuts down on repetitive operations
- Easy-to-read liquid crystal display
- 1000 hours of continuous battery life
- 15 parentheses levels, up to 4 pending operations

B Reliable, professional quality from Texas Instruments. The TI 50 is a powerful, slimline model with sixty functions (including the most useful slide-rule functions) to handle a wide range of mathematical problems. Scientific notation—5-digit mantissa and 2-digit exponent; 2 full accumulating arithmetic memories. Trig and log functions; mean, standard deviation and variance. Built-in battery saver. Operates off two silver oxide batteries (included). Black billfold carry case. Abt. 5 1/2 x 2 7/8 x 3/8"; 3 oz.

032 541 558—Regularly 54.98, Each 49.98

TI 'Business Card' L.C.D.

C From Texas Instruments—a super-slim calculator for business and finance. Pre-programmed financial functions help you compute compound interest, mortgage loans, annuity payments, investment yields etc. Constant memory feature retains data even when the unit is turned off. Financial functions include future value/present value, payment and interest per period. Cost/sell margin keys calculate profit margins directly. Auto % key, Δ% calculates percentage difference between two numbers. 8-digit liquid crystal display. 1000 hours battery life. Uses 2 silver oxide batteries (included). With billfold case. About 3 3/4 x 2 1/4 x 1/8"; weighs abt. 2 oz.

032 541 556—Each 54.99

NS106 Calculator/clock

D Calculator, clock, stopwatch and alarm combined in a precision unit no bigger than your credit cards—it's an ideal travel companion. Calculator functions include full accumulating memory; automatic % key with add-on and discount capability; automatic constants for \times , \div . The stopwatch times single events, laps and pause events to tenths of a second; display indicator for error-free timing. Easy-to-set alarm. Time continues when you are using calculator or stopwatch. 8-digit liquid crystal display. Uses two silver oxide batteries (included) which last about one year. With vinyl carry pouch for calculator and business cards. About 2 1/4 x 3 3/4 x 3/16"; 3 oz.

032 541 543—Each 49.99





ZT electronic auto computer

CUT \$40-\$50 99⁹⁹ without cruise control

A

A The ZT-1 is our most complete auto computer. Its 41 functions plus cruise control keep you informed on the road, helping to save time, gas and money. The new micro-chip technology gives you a small-sized, lightweight unit with a big capacity for checking and storing vital vehicle information. Complete operating manual makes the ZT-1 easy to operate.

SIZE: A compact 6 inches wide x 3 inches high x 1 1/4 inches deep.

INSTALLATION: For all gasoline engines and front-wheel drive vehicles, except diesel. Order adapters for special applications below. Installation available at most Montgomery Ward Auto Centers at extra charge.

ZT-1 computer with cruise control, Manufacturer's Warranty.* Was 179.99 in our 1981 Fall Big Book, page 696.

61 T 97139 LS—Ship. wt. 7 lbs. now 129.99

ZT-2, 41-function computer without cruise control, Manufacturer's Warranty.* Was 139.99 in our 1981 Fall Big Book, page 696.

61 T 97140 LS—Ship. wt. 3 lbs. 4 oz. now 99.99

ADAPTER for electronic fuel-injected cars

61 T 97097—Ship. wt. 1 lb. kit 13.79

FUEL RETURN KIT, required for vehicles with fuel return line from carburetor to fuel tank. Not required if fuel return is from fuel pump to tank.

61 T 97143—Ship. wt. 12 oz. kit 7.79

B FEATURES: At the touch of a button this computer offers instant trip information. By calculating miles traveled and miles to go, you can find your exact location for emergency CB calls. Having determined miles traveled, you can check the amount of fuel used, and the amount of fuel needed to complete your trip. You can also plan your fueling stops for areas where bargain prices are available. Accurate Estimated Time of Arrival allows you to plan your activities. Salesmen can accurately plan appointments. Vacationers can plan their entertainment schedule. Or you can plan your evening stops to avoid last minute problems. Precise speed readings (within 1/10 mph) help eliminate embarrassing and expensive penalties for speeding. When properly calibrated, you get accurate digital speed readouts with any tire size.

SIZE: 10 1/2 in. wide x 2 1/4 in. high x 1 1/4 in. deep.

INSTALLATION: Easy-to-plug-in wiring harness. No magnets to tape on drive shaft—permanent speed installation into speedometer cable at cruise control or from transmission. Lightweight computer head easily screws in under crash pad on dash. Tools needed: screwdriver, pliers and hacksaw. Average installation time for an amateur mechanic is about two hours. Was 109.99 in our 1981 Spring Big Book, page 630.

61 T 97089—Ship. wt. 5 lbs. now 79.99

Adapter kits may be needed for some cars.

61 T 97090—Adapter for Ford. Ship. wt. 1 lb. 9.99

61 T 97091—Adapter for Chrysler. Ship. wt. 10 oz. 9.99

61 T 97092—Adapter for imports. Ship. wt. 8 oz. 9.99

*Write for a free copy of Manufacturer's Warranty, see page 322.



Prince 50-function on-board computer

CUT \$30 79⁹⁹

B

C The most comprehensive stereo unit Dashmaster® has ever designed! Aside from making every state-of-the-art feature available, this designer stereo unit also comes with reversible face plates which allow you to choose from four separate styles. This unit is shown in the black-on-silver style. It also can be arranged in silver-on-silver, silver-on-black, and black-on-black.

FEATURES: A maximum power output of 20 watts per channel. Separate treble control and bass control for precise fine tuning. 4 AM or 4 FM pre-select pushbutton tuning for unlimited program selection. Manual radio tuning control also included. Stereo balance control and speaker fader control. AM/FM selector switch. Stereo/mono switch and FM muting switch. High blend switch. Loudness switch. FM stereo indicator lamp. Auto-reverse for continuous tape play. Locking fast forward and rewind control. Tape eject control and tape program switch. Tape direction indicator lamps. Dolby® noise reduction switch. Standard or metal tape switch. Sendust tape head.

INCLUDES: Installation hardware and instructions. Installs in most American-made cars without cutting, drilling or filing. Manufacturer's Warranty*. See rebate note below.

61 T 73169 LS—Ship. wt. 7 lbs. 289.00

D These speakers have maximum power handling capacity of 100 watts per speaker. Designed for rear deck mounting. Frequency response of 40-20,000 HZ. Complete hardware and installation instructions included. Manufacturer's Warranty*. Was 109.99 in our 1981 Fall Big Book, page 699.

61 T 73086—Made in Japan. Ship. wt. 8 lbs. 13 oz. pair 79.97

E This 4 x 10-inch 3-way speaker pair is designed for mounting in X-body cars. They also have a maximum power handling capacity of 100 watts per speaker. Frequency response of 40-20,000 HZ. Installation instructions and hardware included. Manufacturer's Warranty*. Was 109.99 in our 1981 Fall Big Book, page 699.

61 T 73082—Made in Japan. Ship. wt. 6 lbs. 9 oz. pair 79.97

F For total stereo sound you can add a pair of 5 1/4-inch round Turbo 3-way speakers to your car door. They deliver the same 100 watts per speaker as the other Turbo speakers. Frequency response of 70-20,000 HZ. Installation instructions and hardware included. Manufacturer's Warranty*. Was 109.99 in our 1981 Fall Big Book, page 699.

61 T 73085—From Japan. Ship. wt. 7 lbs. 8 oz. pair 79.97



Dashmaster® Designer AM/FM/cassette stereo with reversible face plates

SAVE \$50 Factory Rebate!
\$289 stereo includes Dolby®, auto-reverse and pushbutton tuning

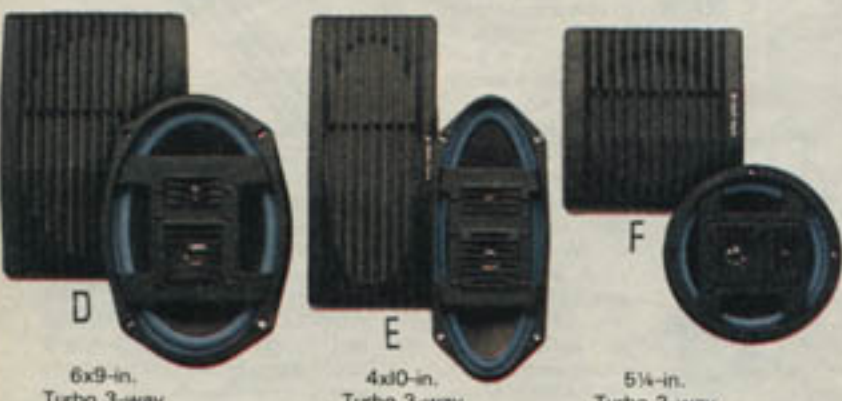

Your Choice CUT \$30 79⁹⁷

REBATE

Wards low price	\$289
Less Mfr.'s rebate	\$50
Price after rebate	\$239

REBATE

HOW TO GET YOUR MANUFACTURER'S REBATE
Upon receipt of your stereo remove the \$50 Rebate Certificate and complete it as directed. Attach to it your validated sales check.
MAIL TO: Kraco Rebate Offer
505 E. Euclid Ave.
Compton, California 90224
Kraco will mail you a check for \$50. Offer ends February 28, 1982. Coupon must be mailed by January 31, 1982. This offer is good only in the U.S.A. and is void where prohibited, taxed or restricted by law. Resellers are not eligible for rebate. Allow 4 to 6 weeks for delivery of your rebate check.



excellent teaching aids



COLECO

REBATE

Wards low price **37⁹⁹**

SAVE \$10

when purchased with Ray-O-Vac batteries
... see pg. 484



PARKER BROTHERS



Kenner

Electronic drag racing



Kenner



MB
MILTON BRADLEY

A Computer Chess . . . 4 levels, from novice to highly experienced.
FEATURES: LCD playing board offers shape recognizable pieces. No loose playing pieces . . . moves are made electronically. Take back up to 3 moves. Ask the computer for help on your next move. Play against an opponent, play against the computer or watch as the computer matches wits against itself. Set up selected moves, mating threats, checks or practice your attacking and retreating tactics.
48 T 14517—Uses 4 "AA" batteries.* AGES: 8 and up. Ship. wt. 7 oz. **98.99**

B Alien Attack™ . . . you command 3 defense ships against attacking aliens.
FEATURES: 4 direction movement, firing. Joy stick control. Multi-color display. 2 skill levels. 16 speeds. Electronic scoring. Sound effects. Uses 4 "C" batteries.* See pg. 484 for how to save \$10 when purchased with Ray-O-Vac batteries.
48 T 14533—AGES: 8 and up. Ship. wt. 1 lb. **37.79**

C Reflex™ . . . 5 electronic games of quick reaction for 1 or 2 players.
FEATURES: 12 action buttons control speed and direction of the 12 whirling balls of light. Adjust skill levels to ability. Automatic scoring, game repeat.
48 T 14509—Uses 6 "AA" batteries.* AGES: 8 and up. Ship. wt. 1 lb. 4 oz. **27.99**

D Redline™ electronic drag race game. You control elapsed time and speed.
FEATURES: Race without "jumping the green" or "blowing" your engine. 4 different classes of racing to test your skill, all with exciting "engine" sounds.
48 T 14542—Uses 2 9-volt batteries.* AGES: 8 and up. Ship. wt. 2 lbs. **39.88**

E Long Beach Grand Prix™ . . . electronic road race game.
FEATURES: Switch on the ignition, choose one of 3 classes of racing and select from 1 to 9 laps around the authentic Long Beach track. Once the flag flashes, shift into first, jam on the gas and go for your best elapsed time. Watch out for those hairpin curves . . . enter at too high a speed and you'll spin out and crash!
48 T 14545—Uses 6 "AA" batteries. AGES: 8 and up. Ship. wt. 1 lb. **43.88**

F Simon™—repeat his sequences of colored lights and sound to win!
FEATURES: Can you repeat exactly Simon's randomly generated sequences? If you slip, Simon will electronically "razz" you! 3 different games. AGES: 7 and up.
48 T 14669—Uses one 9-volt and 2 "D" batteries.* Ship. wt. 2 lbs. 8 oz. **27.99**

SUPER SIMON™ . . . Simon's big brother pushes your memory to its limits
FEATURES: 20 ways to play 5 different games. Repeat sound sequences, try to follow Super Simon or get your friends together for head to head or team play competition. Double the action and the fun. Uses one 9-volt and 2 "D" batteries.*
48 T 14671 X—AGES: 7 and up. Ship. wt. 3 lbs. 8 oz. **37.77**
*Batteries not incl.; order below or on pg. 380.

RAY-O-VAC ALKALINE BATTERIES.
60 T 75026—"C" size alkaline batteries. 2 pkgs. of 2. Wt. 5 oz. 2 pkgs. 3.58
60 T 75028—9-volt alkaline batteries. 2 pkgs. of 1. Wt. 2 oz. 2 pkgs. 3.58

Our Lowest Price Ever on an Old-English Pub-Design Dart Cabinet

Only 17⁶⁶

Includes 6 darts, score board, wall hanger

A Handsome Dart Cabinet of sturdy, fiberboard. Woodgrain vinyl veneer doors are decorated with silk-screen design of sailing ship. Doors have magnetic latches. 14 1/4 in. diameter paper-wound dart board. 1 dart rack, scoreboard (with chalk and eraser) on inside of doors. Includes 6 brass-weighted steel-tipped darts with plastic flights. Playing rules. Measures 19 1/4 x 15 1/4 x 2 1/8 in. when closed. Crafted in U.S.A.

X 641-4684 A—Delivery weight 14 lbs 17.66



A



The Game Cabinet

Holds 10

of your
favorite games

44⁹⁹

- Game chest hangs inside door of cabinet, can be removed for easy carrying
- Chest includes chess/checkers and backgammon boards, cribbage board and pegs, wooden checkers and staunton chessmen, 125 poker chips, playing cards, dice, dice cup and doubling cube

B Game Cabinet crafted of American pine in U.S. John Quincy Adams' coat of arms is silk-screened onto solid-wood doors. Doors have magnetic latches. 14 1/2 in. diameter, 2-sided paper-wound dart board. 1 dart rack, 1 slate-type scoreboard (with chalk and eraser) on inside of doors. Cork-backed interior. Includes 6 brass-weighted steel-tipped English darts with plastic flights. Playing rules for all games. Measures 23 x 17 x 4 in. closed. X 641-0542 A—Delivery weight 16 lbs 44.99



So Convenient!
Shop by Phone—Charge it—and use
Home Delivery. See page 363.



B



Backgammon Board



Chess/Checker Board



Game Chest

Fascinating Electronic Computer Games

C

Computer Gin

64⁹⁹

E

Electronic Poker

39⁹⁹



D

Horoscope Computer

54⁹⁹

C Computer Gin Game by Mattel Electronics.*

Computer controls shuffling, dealing, scoring, and game play. You push buttons for discard or draw. At game's end, computer hand is displayed along with score. Black and white plastic housing. 4 5/8 x 1 3/4 x 7 1/8 in. One 9-volt battery (incl.).

X 641-5111 A—Delivery weight 0.70 lb 64.99

D Horoscope Computer by Mattel Electronics.*

Gives you complete analysis on love, money, career, friends, travel, family, spirit, and creativity with quick and easy computations. All are valid astrological calculations from June 1979 to December 1987. Maroon plastic housing. 6 1/2 x 2 1/2 x 9 1/4 in. One 9-volt battery (incl.).

X 641-2761 A—Delivery weight 0.50 lb 54.99

E Electronic Poker. Player can draw as many as five cards, then it's just like Vegas. Dealer and /or player can bluff, call, fold or double the bets. Winnings and losses are recorded cumulatively. Suits are shown on a fluorescent display. Black plastic housing. 8 1/2 x 6 1/4 x 1 1/2 in. 4 AA batteries, (not incl., order on page 461).

X 641-4981 A—Delivery weight 1.50 lbs 39.99

IBM PC computer entertainment, education and finance/productivity software

Title**	Format	Description	Catalog number	Ship. wt.	Price each
IBM PC computer Entertainment software programs					
Murder by the Dozen	Disk	Identify the guilty party in twelve different mysteries.	62G40091	9 oz.	29.99
Temple of Apsah	Disk	Fantasy role playing game in the Dungeons & Dragons tradition.	62G40092	9 oz.	32.99
Oil Barons	Disk	A strategy game to test your skills and luck.	62G40093	9 oz.	44.99
Snooper Troops I	Disk	Mystery game helps develop vocabulary/reasoning skills.	62G40095	9 oz.	39.99
Zork I	Disk	Text adventure game for thought-provoking fun.	62G40096	9 oz.	32.99
Deadline	Disk	Text adventure mystery—you solve the crime!	62G40097	9 oz.	44.99
Enchanter	Disk	Fate has chosen you to combat a dark and fierce power.	62G40098	9 oz.	44.99
Dig Dug	Disk	Burrow underground to escape fire-breathing dragons.	62G40099	9 oz.	32.99
Donkey Kong	Disk	Help Mario save his girl in this arcade classic.	62G40100	9 oz.	32.99
Ms. Pac Man	Disk	Guide the First Lady of the arcades through multiple mazes.	62G40101	9 oz.	32.99
Pole Position	Disk	Ultra-realistic graphics and the sound of the Grand Prix.	62G40102	9 oz.	32.99
IBM PC education software programs					
Managing for Success	Disk	Learn what it takes to be a better manager.	62G40103	9 oz.	69.99
Master the S.A.T.	Disk	Pre-test tutorial for grade levels 2-8.	62G40104	9 oz.	129.99
Coast to Coast America	Disk	Five games in U.S. history and geography.	62G40105	9 oz.	44.99
Kids on Keys	Disk	Introduce your child to the keyboard.	62G40106	9 oz.	29.99
Facemaker	Disk	Create funny faces and see them come to life.	62G40107	9 oz.	29.99
Delta Drawing	Disk	Draw, color and learn computer concepts.	62G40108	9 oz.	39.99
Most Amazing Thing	Disk	Encourages problem solving by trial and error.	62G40109	9 oz.	32.99
IBM PC finance/productivity software programs					
Managing for Success	Disk	Learn what it takes to be a better manager.	62G40110	9 oz.	69.99
Bank St. Writer	Disk	Word processing program for novice or experienced user.	62G40111	9 oz.	69.99
Home Accountant Plus	Disk	Keep track of 200 plus budget categories for home or business.	62G40112	9 oz.	129.99
File-Catalog-Mail	Disk	Create your own data and retrieval system.	62G40113	9 oz.	109.99

IBM PC jr. computer entertainment, education and finance software

Title**	Format	Description	Catalog number	Ship. wt.	Price each
IBM PC Jr. Entertainment software programs					
Murder by the Dozen	Disk	Identify the guilty party in twelve different mysteries.	62G40114	9 oz.	29.99
Temple of Apsah	Disk	Fantasy game in the Dungeons & Dragons tradition.	62G40115	9 oz.	32.99
Oil Barons	Disk	A strategy game to test your skills and luck.	62G40116	9 oz.	44.99
Zork I	Disk	Text adventure game for thought-provoking fun.	62G40118	9 oz.	29.99
Deadline	Disk	Text adventure mystery—you solve the crime!	62G40119	9 oz.	44.99
Enchanter	Disk	Fate has chosen you to combat a dark and fierce power.	62G40120	9 oz.	44.99
IBM PC Jr. Educational software programs					
Webster Word Game	Cartridge	Sharpen spelling skills and vocabulary while having fun.	62G40121	9 oz.	32.99
Alphabet Zoo	Cartridge	Teaches relationship of letters to sounds.	62G40122	9 oz.	29.99
Facemaker	Cartridge	Create funny faces and see them come to life.	62G40123	9 oz.	29.99
Fraction Fever	Cartridge	Fast-paced action game helps kids understand fractions.	62G40124	9 oz.	29.99
Kindercomp	Cartridge	5 games in 1—draw, scribble, name, sequence and math.	62G40125	9 oz.	29.99
Master the S.A.T.	Disk	Pre-test is scored and evaluated for errors.	62G40126	9 oz.	129.99
Coast to Coast America	Disk	Five games in U.S. history and geography.	62G40127	9 oz.	44.99
Managing for Success	Disk	Learn what it takes to be a better manager.	62G40128	9 oz.	69.99
Kids on Keys	Cartridge	Introduce your child to the keyboard.	62G40129	9 oz.	29.99
Facemaker	Disk	Create funny faces and see them come to life.	62G40130	9 oz.	29.99
Most Amazing Things	Disk	Encourages problem solving by trial and error.	62G40131	9 oz.	32.99
IBM PC Jr. Personal Finance/Productivity software programs					
Managing for Success	Disk	Self-paced instruction in people management.	62G40132	9 oz.	69.99
Bank St. Writer	Disk	Word processing for novice or experienced user.	62G40133	9 oz.	69.99

Apple computer entertainment, education and finance software

Title**	Format	Description	Catalog number	Ship. wt.	Price each
Apple Computer Entertainment Software Programs					
Choplifter	Disk	Guide your craft through enemy defense to rescue hostages.	62G40134	9 oz.	29.99
Death on the Caribbean	Disk	A game of strategy and high adventure.	62G40135	9 oz.	29.99
Dig Dug	Disk	Burrow underground to escape fire-breathing dragons.	62G40136	9 oz.	32.99
Donkey Kong	Disk	Help Mario save his girl in this arcade classic.	62G40137	9 oz.	32.99
Ms. Pac-Man	Disk	Guide the First Lady of the arcades through multiple mazes.	62G40138	9 oz.	32.99
Robotron	Disk	Continuous space warfare action—an arcade classic!	62G40139	9 oz.	32.99
Pole Position	Disk	Ultra-realistic graphics and the sound of Grand Prix.	62G40140	9 oz.	32.99
Dr. J & Larry Bird	Disk	One on One. Basketball that feels real—for one or two players.	62G40141	9 oz.	32.99
Miner 2049'er	Disk	Bounty Bob tries to catch Yukon Ybkan—10 screens!	62G40142	9 oz.	32.99
Temple of Apsah	Disk	Fantasy role game in the Dungeons and Dragons tradition.	62G40143	9 oz.	32.99
Zaxxon	Disk	Fast-paced 3-D arcade like game—meet Zaxxon Robot.	62G40144	9 oz.	32.99
Zork I	Disk	Text-adventure game for thought-provoking fun.	62G40145	9 oz.	32.99
Zork II	Disk	More advanced version of Zork I.	62G40146	9 oz.	32.99
Zork III	Disk	Still more fun with Zork.	62G40147	9 oz.	32.99
Murder by the Dozen	Disk	Identify the guilty party in twelve different mysteries.	62G40148	9 oz.	29.99
Apple Computer Educational Software Programs					
Most Amazing Thing	Disk	Encourages problem solving by trial and error.	62G40149	9 oz.	32.99
Mastering the S.A.T.	Disk	Pre-test is scored and evaluated for errors.	62G40150	9 oz.	129.99
Managing for Success	Disk	Learn what it takes to be a better manager.	62G40151	9 oz.	69.99
Apple Computer Finance/Productivity Software Programs					
Bank St. Writer	Disk	Word processing for novice or experienced user.	62G40152	9 oz.	59.99
File-Catalog-Mail	Disk	Create your own data and retrieval system.	62G40153	9 oz.	84.99
Financial Facts	Disk	Information to help you reach financial decisions.	62G40154	9 oz.	49.99
Money Tool	Disk	Transaction, summary reports and budgeting.	62G40155	9 oz.	49.99
Homework	Disk	Word processing with audio instructional tape.	62G40156	9 oz.	59.99
Managing for Success	Disk	Self-paced instruction in people management.	62G40157	9 oz.	69.99
Home Accountant	Disk	Keeps track of over 200 budget categories.	62G40158	9 oz.	84.99

NOTE: Disk software requires a disk drive. Cartridge software requires minimum computer memory.

See Commodore, Atari and the ADAM computers and software on pages 516-523.

See page 519 for floppy disk organizer/storage case (3429, 3428, key D).



Coast to Coast



Home Accountant



Facemaker



Kids on Keys



Pole Position



Dr. J & Larry Bird

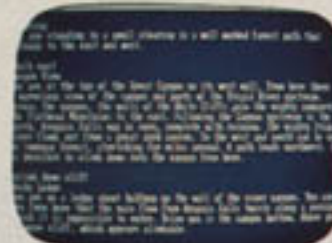

Zork I



Managing for Success



*Michael Jackson*TM



For musical good fun, you can't "beat it"

H "Thriller" would sound great on this Michael Jackson stereo! Manual solid-state phonograph plays both 33½ and 45 RPM records (built-in adapter). On/off, left and right volume controls. Two speakers can be placed up to ten feet apart. Removable clear styrene dust cover. Extra durable tone arm with snap away post, sapphire needle. Flared safety plug.
48 G 36072—Ship. wt. 10 lbs. 8 oz. 54.88

I Michael Jackson doll looks so real, you'll expect him to break into a dance. His outfit includes the Michael Jackson trademark silver glove, and he holds a microphone. 12 in. tall.
48 G 10519—Ages: 4 and up. Wt. 11 oz. 11.99

J Michael Jackson AM headset radio. Michael Jackson and your favorite station will keep you rockin' with this radio and headset. Solid-state circuitry. Can be used with or without headset, and headset is completely adjustable. Belt clip included lets you do other things while listening to your favorite radio station. Easy tuning with on/off, volume control. Uses one 9V battery, not included. To order batteries, see page 490.
48 G 36073—Ages: 6 years and up. Wt. 13 oz. 11.99

Michael Jackson microphone

K Put on your finest glitter glove and boogie down with the Michael Jackson microphone! No longer are you confined to just listening to Michael Jackson, now you can pretend to be Michael Jackson. Wireless microphone projects your voice through any AM radio. Microphone comes with glitter finish and Michael's autograph. So put on your Thriller album and sing along! Requires one 9-volt battery, not included (to order, see page 490). Ages: 6 years and up.
48 G 37318—Ship. wt. 11 oz. 9.97

Genuine wood guitar

L Fine quality wood guitar scaled down for junior strummers. It's easy to play. Has accurately fretted keyboards with position marks. Wood guitar has 6 steel strings and gear tuning pegs. You can magnify the sound with the Menudo amplifier (O) sold on this page. Measures 30½ in. Has anodized tailpiece, shoulder cord. So, get your little musician on the road! Ages: 6 years and up.
48 G 36662 G—Ship. wt. 3 lbs. 18.99

M Fraggles Rock Band 10-piece set comes with all you need for BIG sound; drum and stick, 2 castanets, 2 maracas, 2 bells, a trumpet and a kazoo!
48 G 36082—For ages 4 and up. Wt. 1 lb. 11 oz. 14.99

N Menudo solid-state phonograph. Plays 33½ and 45 RPM records (built-in adapter). Durable tone arm with snap-away post, sealed bottom. Sapphire needle. On/off, volume control. Flared safety plug. UL listed.
48 G 36076—Ages: 5 years and up. Wt. 5 lbs. 29.99

O Menudo solid-state amplifier—amplifies sound while multi-colored pulsating lights flash to the beat. Use with acoustical guitars or as a sing-along mike. 4-in. speaker, 9-ft. mike cord. Uses 4 "D" batteries, not incl. (order from pg. 490). High-impact plastic.
48 G 36078 D—Ship. wt. 1 lb. 8 oz. 24.97

P Join the band! Menudo six-string cutaway guitar features nylon strings with easy tuning friction pegs and an accurately fretted fingerboard with position marks. Use with Menudo amplifier above. Comes with pick and music/instruction book. 30 in. long. Ages: 6 and up.
48 G 36077—Ship. wt. 2 lbs. 2 oz. 11.97



1 and 2. Manual typewriters . . . in just the right size for beginning typists. Child-size, yet designed like and work like an adult model. Furnished with replaceable cartridge ribbon. Keyboard types capitals, numbers, fractions, punctuation plus has a figure shift key. Carriage return lever, paper release. Made of high-impact plastics with steel mechanical parts. Imported. Extra ribbon sold below. For ages 6 years and up.

1. The Sears Writer 2 with 54-character keyboard is 11 $\frac{1}{4}$ x11x4 $\frac{1}{2}$ inches high. 49 C 44630—Shipping weight 3 pounds 8 ounces. . . **\$24.99**

2. The Sears Writer 4 has an 80-character keyboard with line rollup, paper adjuster, scale and deluxe trim. Protective carrying case. 11x11 $\frac{1}{2}$ x4 $\frac{1}{2}$ in. high. 49 C 44628—Shipping weight 4 pounds 11 ounces. . . **\$29.99**

Extra cartridge ribbon for items (1 and 2), (not shown). 49 C 44631—Shipping weight 2 ounces. . . **\$2.99**

3 and 4. These Christmas toys are calculated to add up to fun! Features include working keys with realistic buzzer sound, manual tape dispenser, automatic sliding cash drawer with ringing bell and play money. Steel housing with plastic base and drawer.

3. Get your child this electronic play register and let him make the sale. Your youngster can enjoy feeling like Mom and Dad at the checkout counter and soon learn the value of a dollar, too. Requires 4 "C" batteries, sold separately on page 459. For ages 3 years and up. 49 C 44583—Shipping weight 26 pounds. . . **\$11.99**

4. This electronic calculator/cash register takes youngster a step further than (3). In addition to helping your child learn to count, this toy adds, subtracts, multiplies, divides and clears, making it perfect for the older pre-schooler who is ready for the "next step." Requires 2 "AA" batteries, sold separately on page 459. For ages 5 years and up. 49 C 44573—Shipping weight 1 pound. . . **\$16.99**

5. Bankers' hours? Your child will play even longer with this credit-card bank. Activate by inserting credit card into special slot. Large LCD screen shows addition/subtraction calculations. Push-button operation for deposit/withdrawal transactions, balance, opening of drawer. Steel housing with plastic base and drawer. Requires 6 "AA" batteries, sold separately on page 459. For ages 5 and up. 49 C 44589—Shipping weight 1 pound 6 ounces. . . **\$18.99**

6. The Tomy® "Tutor" Play Computer™ is educational and entertaining. It's the perfect "first" computer for pre-schoolers. 12 different pictures become animated when child pushes the space bar. Plastic. No batteries required. For ages 2 $\frac{1}{2}$ to 5. 49 C 45177—Shpg. wt. 1 lb. . . **\$14.88**

7. New at Sears! Super Vision™, from Tomy®, is the toy that has 27 different pictures and a telescope viewer that creates an "x-ray" to let you see inside of each picture. Plastic. For ages 3 to 6 years. 49 C 45170—Shpg. wt. 1 lb. . . **\$14.88**



B



C



A

A T.I.'s Speak & Spell—a remarkable talking machine with electronic voice and brain. Pronounces the word, then operator keys in the spelling.

FEATURES: Over 150 words, 4 levels of difficulty. Converts to pronunciation drill. Word games; scorekeeping. Solid state speech—no tapes, records or moving parts. Activities booklet incl. 10x7x1½ in. Uses 4 "C" Batteries (not incl.; order below). Mfr.'s warranty.*

67 T 8901 LS—Ship. wt. 1 lb. 13 oz. **69.99**

PADDED CASE (not shown).

67 T 8903—Ship. wt. 8 oz. **4.99**

SAVE \$2 when you buy Speak & Spell with case.

67 T 8823 LS—Ship. wt. 2 lbs. 5 oz. **72.98**

ADDITIONAL WORD MODULES: Approx. 140 words ea.

VOWEL POWER for grades 2-4.

67 T 8904—Ship. wt. 8 oz. **19.99**

SUPER STUMPERS for grades 4-6.

67 T 8905—Ship. wt. 8 oz. **19.99**

SUPER STUMPERS for grades 7, 8.

67 T 8906—Ship. wt. 8 oz. **19.99**

B T.I.'s Spelling B displays the word as you spell it: 3 levels of difficulty, kindergarten to intermediate.

FEATURES: Colorful pictures of 264 familiar objects to spell. Pre-spelling and 3 activity games. Activities book, book-style carrying case incl. Uses one 9V battery (not incl.; order below). Automatic power-off prevents accidental battery drain. Abt. 6½x4½x1½ in. including case. Manufacturer's warranty.*

67 T 8900 LS—Ship. wt. 10 oz. **37.99**

C T.I.'s Speak & Read duplicates the human voice to build reading skills naturally by associating the written word with the spoken word.

FEATURES: Introduces 250 of the most basic English words, with 3 levels of difficulty for pre-school through third-grade level. Uses fast-paced "see it/hear it" techniques to develop vocabulary skills and word meanings. Solid-state speech—no tapes, records or moving parts. Instructions and 64-page activity booklet included; in book-style case. Also includes earphone for silent study. 10x7x1½ in. Uses 4 "C" batteries (not incl.; order below). Manufacturer's warranty.*

67 T 8913 LS—Ship. wt. 2 lbs. 7 oz. **69.99**

ADDITIONAL READING MODULES; each with book.

WHO'S WHO AT THE ZOO; Grade 2.

67 T 8916—Ship. wt. 8 oz. **19.99**

SEA SIGHTS; Grade 3.

67 T 8915—Ship. wt. 8 oz. **19.99**

DOG ON A LOG; Grade 1.

67 T 8914—Ship. wt. 8 oz. **19.99**

D NSC's Math QuizKid—tells you only if your answer is right or wrong.

FEATURES: 33-pg. QuizBook of puzzles, games and problems. Owl flashes green eye for correct answers, red eye for incorrect answers. Uses one 9V battery (not incl.; order below). Tote bag incl. Mfr.'s warranty.*

67 T 8882—Ship. wt. 10 oz. **7.99**

E NSC's QuizKid "Racer" gives thousands of 10-question math quizzes at 3 levels of difficulty, for children 6 years and up.

FEATURES: Rewards correct answer with a green light—gives a second chance to wrong answers, gives correct answer after 2 wrong guesses. "Pro" key increases difficulty. "Complex" key asks child to supply one factor instead of the answer (2+7=6). Uses one 9V battery (not incl.; order below) or AC adapter sold below.

67 T 8910—Mfr.'s warranty.* Ship. wt. 10 oz. **9.99**

PADDED CASE (not shown) for (E) or (F).

67 T 8986—Ship. wt. 3 oz. **3.99**

SAVE \$2 when you buy QuizKid "Racer" with case.

67 T 8826—Ship. wt. 13 oz. **11.98**

F T.I.'s Little Professor™ has 18,000 math problems for ages 5 up, at any of four learning levels.

FEATURES: Poses 10 questions in chosen function (+, -, x, ÷); child keys in the answer—if correct, next problem appears—and the Little Professor keeps score. Uses one 9V battery (not incl.; order below) or AC adaptor.

67 T 8857—Mfr.'s warranty.* Ship. wt. 12 oz. **13.99**

SAVE \$2 when you buy Little Professor with case above.

67 T 8825—Ship. wt. 15 oz. **15.98**

AC ADAPTER for (D), (E), (F). Uses household current.

67 T 8858—UL listed. Ship. wt. 7 oz. **4.99**

ALKALINE BATTERIES furnish long-life power.

9V BATTERY. Ship. wt. each 2 oz.

60 T 75018 X—2 for 3.58. **4 for 6.44**

"AA BATTERIES. Pkg. of 2; ship. wt. 4 oz.

60 T 75017 X—2 pkgs. 2.78. **4 pkgs. 5.00**

"C" BATTERIES. Pkg. of 2; ship. wt. 6 oz.

60 T 75016 X—2 pkgs. 3.58. **4 pkgs. 6.44**

*Manufacturer's warranty; write for your free copy; see page 322.



A Christmas convenience—charge it 3 ways

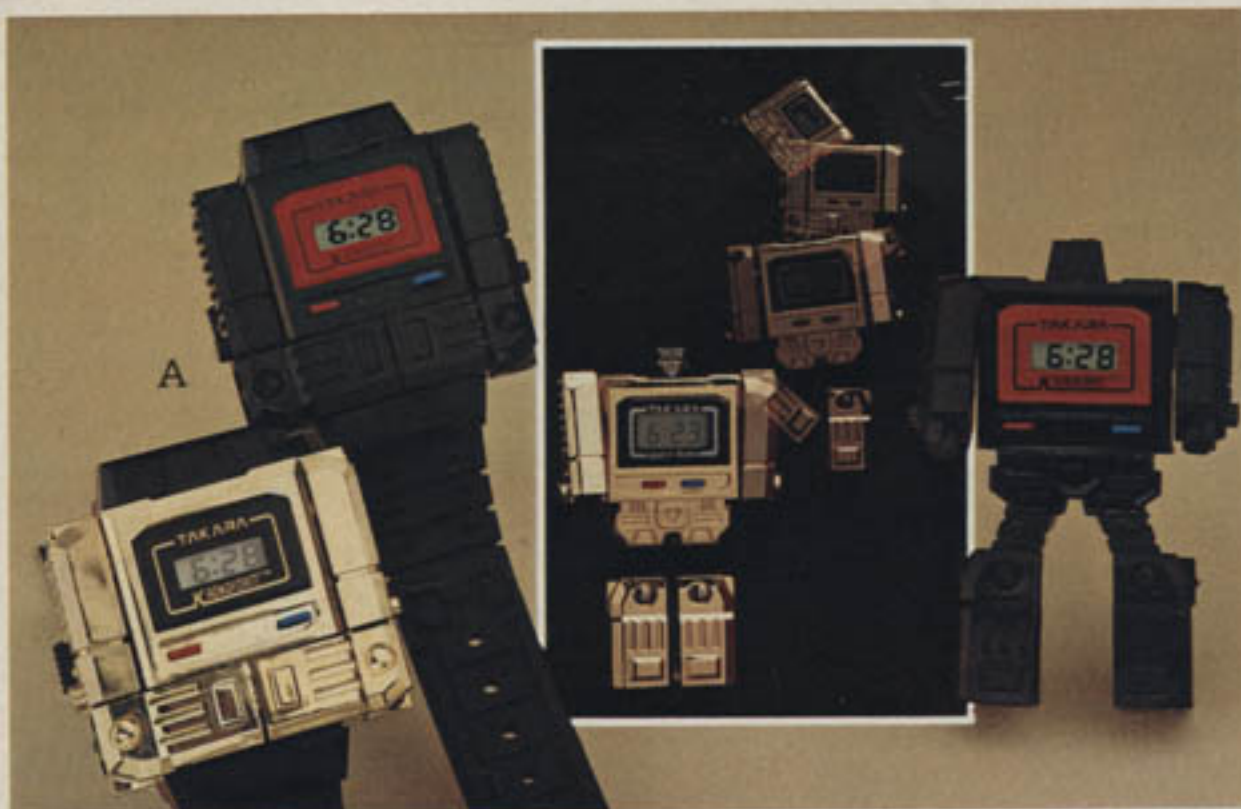

Robots bring you the world of tomorrow today

A Kronoform™—The Robot Time Machine is a watch that snaps off wrist band and converts to a fully articulated robot with movable arms, legs and head... can also be transformed into other outer-space shapes. LCD readout shows month, date, hours, minutes, seconds. Battery included. Ages: 4 and up. Ship. wt. 4 oz.
 48 G 62843—Black color 11.99
 48 G 62844—Gold color 11.99

B Tommy the Talking Robot™ doesn't let anything stop him. When he walks into an object he just bounces off and continues on his way. Flashing lighted eyes guide him in the dark. Button in his head activates voice messages and eerie space sounds. He can carry items in his spring-action hands. 10 in. high. Uses 2 "C" batteries (not included, see page 490). Ages: 3 and up. Ship. wt. 1 lb. 8 oz.
 48 G 60314 11.99

C Multi-Force Robot of the Future can be transformed into 14 different space-fighter shapes. About 6½ in. tall. Includes 5 commando figures and a launcher for space fighters. Ages: 5 and up. Ship. wt. 1 lb. 2 oz.
 48 G 61064 13.99

D Here's Inspector Gadget™ the famous fumbling detective. Pop-off hand and extending neck and legs are just some of his many zany moving parts. His crazy gear includes a gyrocopter, hammer and umbrella for his hat. He wears a realistic trench coat and is over 12 in. high with neck extended. Ages: 5 and up. Ship. wt. 1 lb. 12 oz.
 48 G 62917 13.99

E Starriors Cosmittor™... the powerful remote-control war machine from Tomy. "Cricket" controller clicks to direct Deadeye to advance, turn and then fire his Demolishers. 7½ in. high. Uses 2 "C" batteries, not included; order on page 490. Ages: 4 and up. Ship. wt. 1 lb. 2 oz.
 48 G 62902 19.97

F-G Starriors Wastors™ from Tomy. Each of these high-powered war machines has its own unique built-in, wind-up weapon. Wastors can be reconstructed into many different weird shapes. Mini Marvel Comic Book included. Ages: 4 and up. Ship. wt. 1 lb. 1 oz.

(F) Set of two Destroyers includes Slaughter Steelgrave and Gauge.
 48 G 62907 set 9.97

(G) Set of two Protectors includes Hot Shot and Cut Up.
 48 G 62908 set 9.97

Save this catalog. You can order toys until June 29, 1985.



9 Petite Alpha Writer 18⁸⁸



10 20-Pc. Tool Set with Wooden Case 13⁴⁴



11 Work Bench with Tools 34⁸⁸ Set

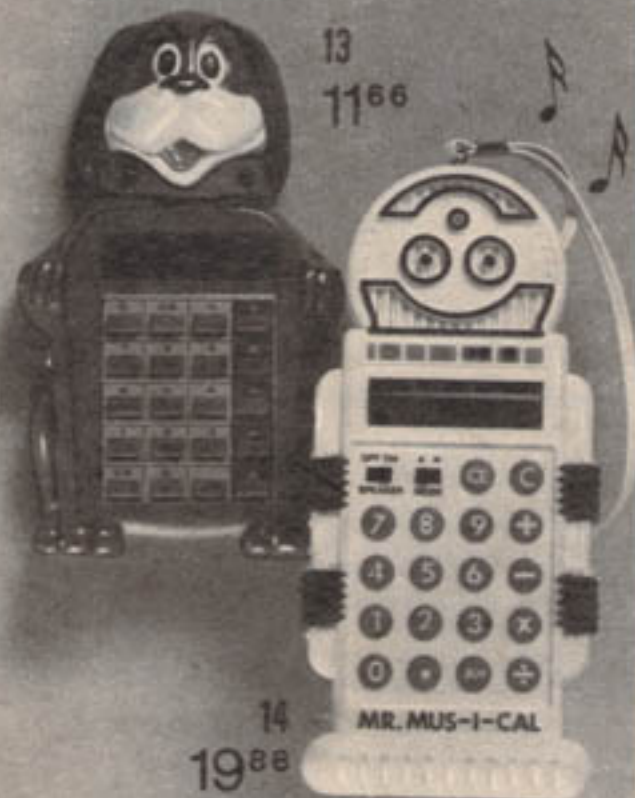

13 Puppy Calculator 11⁶⁶

14 Mr. Mus-I-Cal 19⁸⁸

12 Blueprint Work Bench with Tools 27⁸⁸ Set



More Than Toys....They Help Form Good Work Habits Early

1 Electronic Cash Register/Calculator. Adds, subtracts, multiplies, divides, totals up to 6-digits, clears. Bell rings when drawer opens. LED read-out display. On/off switch, receipt compartment. Plastic housing. 7 $\frac{1}{4}$ x6x4 $\frac{3}{4}$ in. high. Uses one 9-volt battery—not included, sold on p. 461. Includes receipt roll, play money. Imported from Hong Kong. Ages 5 to 9 years. XU 925-8278 A—Del. wt. 1 lb. 16.44

2 Tom Thumb Cash Register rings up sales from 1¢ to \$1 with 8 keys: "Clear", "Open" levers, "No Sale" key. Bell rings when drawer in front opens. Baked-on enamel finish, chrome-tone front. 6 $\frac{1}{2}$ x6 $\frac{3}{4}$ x7 in. high. Play money included. Imported from Hong Kong. Ages 5 to about 8 years. XU 923-9229 A—Del. wt. 2.25 lbs. 6.84

3 Electronic Cash Register. Automatic sliding cash drawer has ringing bell. Lighted read-out window. 12 working keys make buzzing sound when pressed. On/off switch, manual tape dispenser. Uses two "D" batteries—not included, sold on page 461. Plastic. 6 $\frac{1}{4}$ x6 $\frac{1}{2}$ x6 $\frac{3}{4}$ in. high. Imported from Hong Kong. Ages 3 to about 10 years. XU 923-4931 A—Del. wt. 1.60 lbs. 9.33

4 & 5 Telephone Intercoms. 33-ft. of wire lets you ring a friend "long distance". Plastic. Imported from Malta. Ages 5 to 10 years.

[4] Standard Phones. Dial on one, the other buzzes, lights up. Use 4 "D" batteries—not included, sold on p. 461. 6 $\frac{1}{2}$ x4 $\frac{1}{4}$ x3 $\frac{1}{2}$ in. high. XU 925-2966 A—Del. wt. 2 lbs. Pair 10.89

[5] "NASA" Contemporary Pushbutton Phones. Rings as you dial. Use 6 "C" batteries—not included, sold on page 461. 8x1 $\frac{3}{4}$ x3 in. high. XU 925-8286 A—Del. wt. 2 lbs. Pair 11.99

6 & 7 Deluxe Easy-Writer* Typewriters. 84-character typewriters really work! Carriage-return lever with line roll-up. Shift and back space keys. Capitals, lower case letters, figures. Automatic ribbon reverse. Die-cast metal type heads, plastic housing. Imported from Japan. Ages 6 to about 10 years.

[6] Model 2600. Comes with portable plastic carry case with handle. 11 $\frac{1}{2}$ x11 $\frac{3}{4}$ x4 $\frac{1}{4}$ in. high. XU 925-8237 A—Del. wt. 4.55 lbs. 32.88

[7] Model 2500. 11 $\frac{1}{2}$ x11 $\frac{1}{2}$ x4 in. high. XU 925-8245 A—Del. wt. 3.50 lbs. 28.77

8 Easy-Writer* Model 210. 56-character typewriter. Carriage-return lever with line roll-up. Capitals and figures. Automatic ribbon reverse. Die-cast metal type heads, plastic housing. 11 $\frac{1}{2}$ x11 $\frac{1}{2}$ x4 $\frac{1}{2}$ in. high. Imported from Japan. Ages 6 to about 10 years. XU 925-8252 A—Del. wt. 3.35 lbs. 23.99

Extra Typewriter Ribbon. Black. Fits typewriters [6] to [8] above. Imported from Japan. XU 925-8260 A—Del. wt. 0.25 lb. 1.59

9 Petite Alpha Writer. Types 27 characters—has special keyboard ordered alphabetically. Types complete alphabet in capital letters. Space bar, line roll-up. Fixed strip ribbon. Plastic housing. 10x3 $\frac{1}{2}$ x10 $\frac{1}{2}$ in. long. Ages 6 to 8 years. XU 925-8310 A—Del. wt. 2 lbs. 18.88

10 20-Pc. Tool Set in Wooden Case. Young builders set includes: hand saw, hammer, ruler, plane, pliers, Phillips head screwdriver, 6- and 6 $\frac{3}{4}$ in.-long screwdrivers, sand block, sandpaper, drill, jig saw with 3 extra blades, level, folding rule, T-square, C-clasp, mitre box. Stores in 14 $\frac{1}{2}$ x10 $\frac{1}{2}$ x3 $\frac{1}{4}$ in. high case with metal clasps, carry handle. Imported from Taiwan. Ages 8 to about 12 years. XU 925-8294 A—Del. wt. 4.40 lbs. Set 13.44

11 Work Bench with Tools. Wood and hardboard bench. Work area is 32 $\frac{1}{2}$ x16 in. Storage shelf below pegboard rack outlines tools. 18-in. ruler printed on bench molding. Comes with over 20 tools, including hammer, pliers, coping saw, 2 screwdrivers, wood chisel, folding rule, awl, vise, compass. 25 peg hooks. Easy to assemble. Ages 8 to 12 years. XU 923-3289 A—Del. wt. 27.35 lbs. Set 34.88

12 Blueprint Work Bench with Tools. Wood and particleboard work bench, 16 $\frac{1}{4}$ x33 in. work area. Storage area with sliding doors opens to two large shelf spaces. Tools include: hammer, saw, screwdriver, pliers, triangle, square, sandpaper, ruler, coping saw with 3 extra blades, pencil (nails not incl.) Peg hooks. Easy to assemble. Ages 8 to 12 years. XU 925-8302 A—Del. wt. 27 lbs. Set 27.88

13 Puppy Calculator. Lovable pooch adds, subtracts, multiplies, divides. 8-digit read-out screen has floating decimal. Includes AC power jack (adapter not included). Uses one 9-volt battery—not included, sold on page 461. Plastic case 4x2x6 $\frac{1}{2}$ in. high. Imported from Hong Kong. Ages 5 to 9 years. XU 925-6314 A—Del. wt. 0.70 lb. 11.66

14 Mr. Mus-I-Cal—a calculator, math teacher, and musical instrument—three modes in one! Calculator has 4 functions. Math teacher plays victory tune when kids guess right, funeral march when wrong. Musical instrument plays 10 notes. Has 6-digit read-out and speaker, function and on/off switches. Uses one 9-volt battery—not included, sold on page 461. Carry strap, songbook included. Plastic housing. 7x3 $\frac{1}{4}$ x1 $\frac{1}{2}$ in. high. Ages 5 to 9 years. XU 925-8328 A—Del. wt. 0.70 lb. 19.88

TOYS AREN'T JUST FOR CHRISTMAS. Save this catalog. Order toys from pages 375-527—at these low prices—until August 15, 1981.

OFFICE

• EASY ORGANIZATION

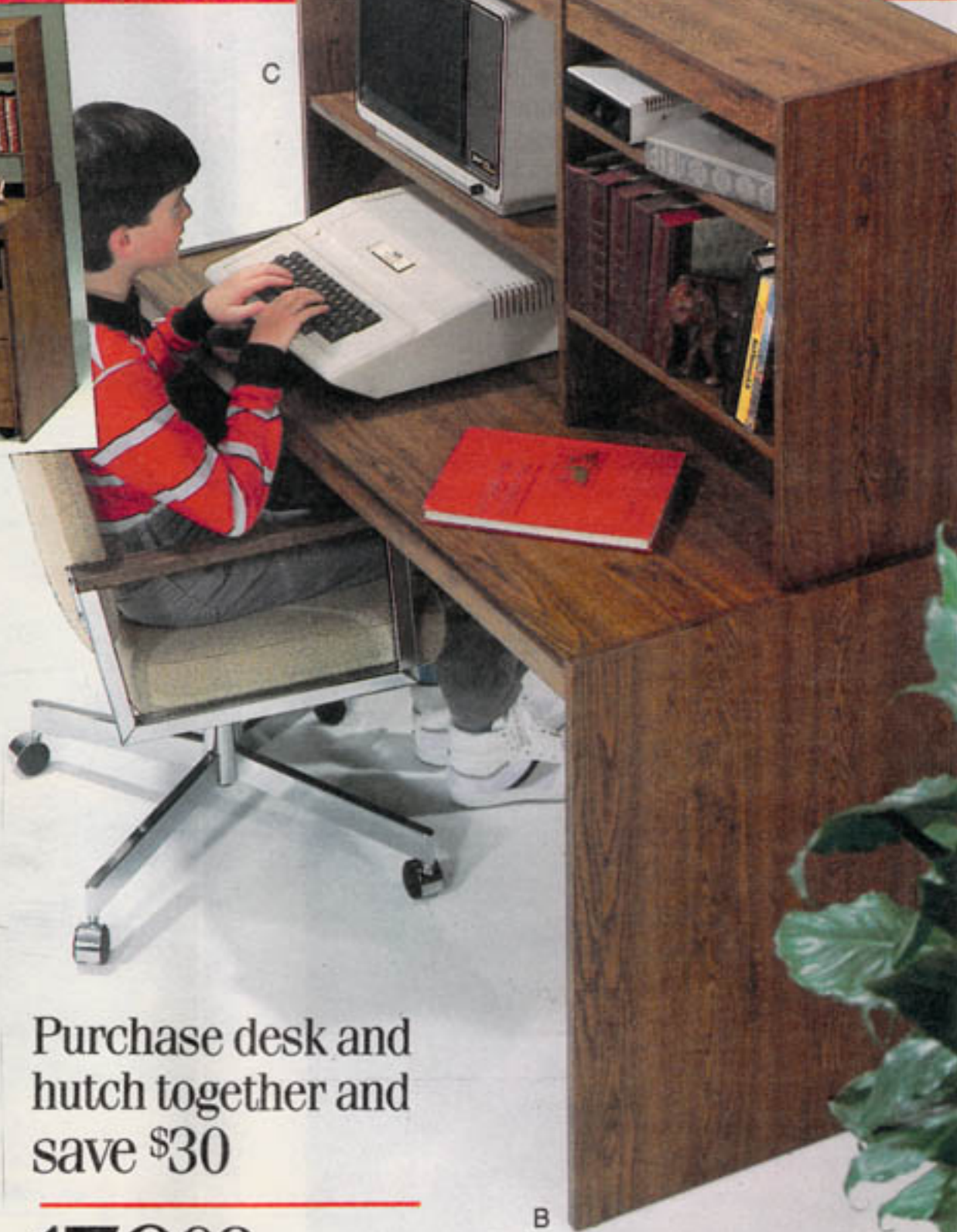

save \$20

A Low-Back Tilter/Swivel Chair has 4-prong base and chromed 2" dual-wheel casters for mobility with stability. Thick foam-padded seat. Solid hardwood arms. Polypropylene fabric cover. About 23 x 22 x 31" high. Beige only. Sears reg. 159.99.

032 546 345 DL—Each 139.99



Dual adjustable back

A

Thickly foam-padded seat

Pneumatic height adjustment

Stable 4-prong base

Dual-wheel 2" casters

Purchase desk and hutch together and save \$30

179⁹⁸

We've taken note of the trend towards woods in home decor and adapted our space-efficient office furniture to it. Medium Oak finish laminate adds warmth plus durability. Components can be arranged to suit your needs—you can even store file cabinet and trolley under desk when they're not in use.

SAVE 30.00 off sep. cost of desk and hutch. Sep. cost 209.98.
032 546 748 DLE2—Ens., ea. 179.98

SAVE 80.00 off sep. cost of desk, hutch, file cabinet, trolley. Sep. cost 369.96.
032 546 746 DLE4—Ens., ea. 289.96

B Desk. Measures 48 $\frac{3}{4}$ x 24 x 29" high.
032 546 743 DL—Easy to assemble. Ea. . . 119.99

C Hutch. 3 adjustable shelves. Measures about 48 x 12 x 24" high.
032 546 747 DL—Each 89.99

D Filing Cabinet holds legal or letter size folders. 2 drawers, solid Oak handles. Fully finished back. Convenient open shelf. Casters. Measures about 16 x 19 $\frac{1}{4}$ x 26" high.
032 546 744 DL—Each 99.99

E Typing Trolley. Multi purpose, can be used as a serving cart. Casters. Measures about 25 $\frac{1}{4}$ x 15 $\frac{3}{4}$ x 26" high.
032 546 745 DL—Each 59.99



featuring our complete selection of office furniture



Electronic learning toys help children with cognitive skills and manual dexterity. Voice synthesis encourages child's performance.



Save \$10
89⁹⁹

A Talking CompuTron™ ...because their future starts now! Develops music, math, logic and strategy. 19 activities and games with 3 skill levels. A friendly computer voice makes learning fun. Unit automatically shuts off when not in use. Instruction book included (expansion cartridges sold below). English. For ages 5 and up. About 8 x 8 x 5". Uses 6 "C" batteries (not included—sold on page 398) or AC adapter (item C sold below).

492 541 048—Sears reg. 99.99. Each89.99

B SAVE 2.00 on CompuTron™ Cartridges. Each with storybook. State no.: 01(Let's Visit the Zoo), 02(Rocket to Zenod), 03(A Day to Bake) or 04(Dress Up and Theatre).

492 541 077 C—English. Sears reg. 24.99. Ea.22.99

C AC/DC Universal Adapter. Adjusts from 3 to 12 Volts for use with a variety of units.

492 541 187—Each9.99

B
SAVE \$2

ARCADE GAMES



(1) Foto™ Electronic Bowling. Bowl your own game or compete against another player. You control where the ball goes. Each player's score plus frame number, strikes, spares and extra 10th frame balls all show on LED display. Flashing lights, different musical sounds for strikes, spares, gutter balls and misses. Portable and self-contained.

CONSTR: Plastic, 15x4½x3¼ in. high.
FOR AGES: 8 years to adult.
ORDER INFO: Uses two 9-volt batteries, not incl. (order below). Warranted by Cadaco Inc.; for free copy, see p. 322.

49 C 65385—Wt. 1 lb. 11 oz. . . . \$28.47
9-volt Alkaline Battery
49 C 46859—Wt. 2 oz. . . . Each \$1.49

Package of 2 "AA" Alkaline Batteries
49 C 46819—Wt. 2 oz. . . . Pkg. \$1.19

Package of 2 "C" Alkaline Batteries
49 C 46839—Wt. 5 oz. . . . Pkg. \$1.39

(2) Rocket Pinball. Electronic hand-held pinball game for 1 or 2 players. With 7 adjustable skill levels. Features an "all electronic" playing field with electronic sounds, realistic "ball" movement, 4 "bumpers" with point values of 4, 10 and 20 points. 5 balls per player each game with a free ball for 200 or more points. Electronic LED digital scoring keeps separate scores for each player. Players alternate just like real pinball.

CONSTRUCTION: Plastic, 6½x3½x1½ inches deep.
FOR AGES: 7 years to adult.
ORDER INFO: Uses 4 "AA" batteries, not incl. (order at left). Warranted by Interstate Industries, see p. 322.

49 C 65454—Shipping weight 10 oz. . . . \$24.97

(3) Compu-Bowl. Hand-held electronic bowling game. Push straight-ball button to start electronic ball, then push curve ball button to aim it into the "pocket". Bell sounds when "pins" are hit and light flashes when you get a strike. Reset button for replay. Lighted pins visible from any angle. Manually operated frame counter. Score pad incl. Plastic, 9½x3½x2¼ in. high. Imported.

FOR AGES: 3 years to adult.
ORD INFO: Uses 2 "AA" batteries, not incl. (order, left).
49 C 65262—Shipping weight 12 oz. . . . \$9.99

(4) Spider-Man/Hulk® Pinball. Electronic hand-held pinball game for 1 or more players. Features dual independent flippers, automatic tilt, bonus scoring and electronic sounds as you play and score. Digital LED scoring advances when hit made. Plastic, 8½x5½x2¾ inches high. Ages 6 to adult.

ORDER INFO: Uses 1 9-volt battery, not incl. (order at left). Warranted by Castle Toy Co., see page 322.
49 C 65545—Shipping weight 14 oz. . . . \$19.99
© Marvel Comics Group.

(5) Hit 'N Missile. Knock the enemies' aircraft out of the sky! Aircrafts fly across the screen in both directions. Choose your target: helicopters and biplanes moving at low speeds or airplanes at high speed for more points. Release the missile from launching pad by moving control from left and right for better placement. Red flash appears on screen with each hit. Course of the missile can even be changed after it's fired. Score registers automatically on digital display. Automatic timer, on/off switch. Plastic, 9½x3x7¼ inches high.

FOR AGES: 6 years to adult.
ORD INFO: Uses 2 "C" batteries, not incl. (order, left).
LAST DATE TO ORDER THIS ITEM IS JAN. 31, 1980
49 C 65054—Shipping weight 1 lb. . . . \$18.47

For the young . . . and young at heart

1 Centurion™ digital watch comes with its own plastic assault pieces and handy carrying case. Time display plus month, date. Imported. Warranted by Impulse LTD†. State robot number:
223—Max Ray, green (6 assault pieces)
206—Ace McCloud, blue (10 assault pieces)
203—Jake Rockwell, yellow (5 assault pieces)
4 E 45479H—Shpg. wt. 3 oz. . . \$9.99

2 \$3 less thru December 15th. Boy's digital alarm is water-resistant to 30 meters†. Shows time plus date. Imported. Warranted by Nelsonic††. 4 E 45611—Shpg. wt. 2 oz. Thru 12/15 \$6.99 . . . After 12/15 \$9.99

3 \$1 less thru December 15th. An alarm watch you can count on. It's also a calculator that adds, subtracts, divides. Shows time, day, month, date on command. Plastic with stainless steel back. Imported. Warranted by Nelsonic††. 4 E 45481—Shpg. wt. 2 oz. Thru 12/15 \$8.99 . . . After 12/15 \$9.99

4 Lightweight, ultra-thin digital with 5 function display; hour, minute, month, day, date. Black plastic band. Imported. Warranted by Quintel††. Shpg. wt. 1 oz. 4 E 45474 . . . \$3.99

5 Gray robot digital watch has 5 function display; hour, second, month, day, date. Removable black plastic strap. Imported. Warranted by Quintel††. Shpg. wt. 2 oz. 4 E 45478 . . . \$3.99

6 Pac-Man™ plastic digital game watch. Time readout plus date, day, alarm. Imported. Warranted by Nelsonic††. 4 E 45461—Shpg. wt. 3 oz. . . \$19.99

7 Q*bert™ plastic game watch . . . help him travel from one cube to another or he'll get trapped. Sound effects. Time readout plus date. Imported. Warranted by Nelsonic††. 4 E 45641—Shpg. wt. 3 oz. . . \$19.99

8 Bubble mechanical analog plastic watch. Airplane second hand orbits the map of USA on dial. Stainless steel band. Imported. Warranted by Quintel††. Shpg. wt. 2 oz. State color number: 217—silver 219—black 4 E 19530H . . . \$9.99

9 thru 12 Score big with your favorite team by sporting officially licensed NFL name and insignia. All are battery operated (battery included) except item (10). Imported. Warranted by Bradley Time††.

9 Adult's digital alarm chronograph with hourly chime. Base metal with stainless steel bracelet. Display shows time readout, month, date on command. Sticker application for all 28 NFL teams included. T 4 E 45483—Shpg. wt. 4 oz. . . \$17.99

102—Patriots	115—Bears	122—Giants
109—Dolphins	116—Cowboys	123—Eagles
110—Jets	118—Packers	125—49 ers
111—Raiders	119—Rams	126—Redskins
112—Steelers	120—Vikings	127—Seahawks
114—Falcons		

10 Youth's analog watch with base metal case, vinyl strap and 1-jewel movement. State team number from above. T 4 E 18763H—Shpg. wt. 2 oz. . . \$14.99

11 Youth's quartz digital water-resistant watch. Plastic case, vinyl strap. Shows time display and date. Also has 15-minute stop watch timer. State team number from above. T 4 E 45658H—Shpg. wt. 2 oz. . . \$9.99

12 Quartz digital alarm clock has nightlight. Plastic helmet is the authentic NFL shape. 4½x3¾x4 inches. State team number from above. T 4 E 74221H—Shpg. wt. 4 oz. . . \$16.99

††Write for free copy, see p. 371.

©1981 Bail Midway Mfg. Co.

©1982 Gottlieb Co./Columbia Pictures

©1986 Impulse, LTD. All Rights Reserved.

†See water-resistant note, p. 216

©1985 Impulse LTD.

Items with a "T" prefix (such as T 4 E 45483) could take extra time for delivery

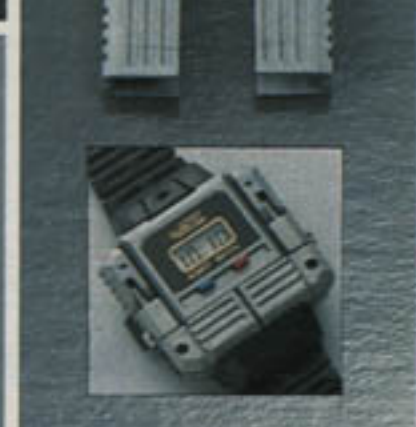

READY FOR MORE POWER?

Commodore 128D has twice the memory of the 64C, plus built-in disk drive



\$499.99 \$17 MONTHLY
NO PAYMENTS TIL JANUARY*

5 Built-in 7.0 Microsoft® BASIC. 40-column, 25-line display when hooked up to your TV, or order monitor (2) for 80 columns. 128K memory, expandable to 640K. Built-in disk drive loads programs 5 times faster than 64C. 92-character detachable keyboard. Runs all 64C software. Warranted.** Imported. 3 E 32220C—Wt. 22 lbs ... \$499.99

6 \$11 monthly, no payments 'til January.* Sears SR2000 printer for any computer we sell. Prints 130 CPS in draft mode, 30 CPS near letter-quality. Elite, condensed, enlarged, italic, other type styles. Warranted.** Imported. 3 E 32400C—Wt. 18 lbs ... \$219.99

Cable connects computers (1) or (5) to printer (6). T 3 E 20901—Wt. 8 oz ... \$4.99

Black replacement ribbon for (6). T 3 E 76735—Wt. 3 oz ... \$4.99

7 White bond computer paper, 9½x11 in. 20-lb. stock. Pkg. of 250 sheets. T 3 E 76709—Wt. 3 lbs. 4 oz ... Pkg. \$3.99

15-lb. stock. Package of 1000 sheets. T 3 E 76715—Wt. 13 lbs ... Pkg. \$14.99

White thermal paper for Okimate 10 and 20 printers. Package of 250 sheets. T 3 E 20637—Wt. 3 lbs. 4 oz ... Pkg. \$6.99

8 Amaray universal plastic printer stand allows stack of paper to feed from beneath. T 3 E 20927—Wt. 14 oz ... \$9.99

9 thru 11 Plastic disk storage cases.

9 Holds thirty 3½-in. floppy disks. T 3 E 20928—Wt. 15 oz ... \$7.99

10 Holds fifty 5¼-in. floppy disks. T 3 E 20941—Wt. 1 lb. 7 oz ... \$7.99

Holds ten 5¼-in. floppy disks. T 3 E 20942—Wt. 11 oz ... \$2.99

11 Case with lock holds one hundred 5¼-in. floppy disks. T 3 E 20930—Wt. 3 lbs. 3 oz ... \$14.99

12 Joysticks for C64, 64C, C128 and Atari computers. Warranted.** Imported.

Arcade-quality dual fire button on base and fire button on plastic grip controller. T 3 E 20885—Wt. 10 oz ... \$12.99

Fast, accurate single-fire button on base. T 3 E 20883—Wt. 8 oz ... \$5.99

Note: Catalog numbers with a "T" prefix may take extra time for delivery. **Warranted by Sears or manufacturer. Write for free copy, see page 304. *See page 305.

Suncom Tac 1+ joystick for Apple or IBM and compatible computers. Warranted.** Imported. T 3 E 20886—Wt. 1 lb. 2 oz ... \$24.99

13 Double-density 5¼-in. floppy disks. Pkg. of 10. Plastic storage case. Wt. pkg. 14 oz.

Certron disks. T 3 E 20605—Single sided ... Pkg. \$6.99
T 3 E 20609—Double sided ... Pkg. \$7.99

Scotch disks. T 3 E 20607—Single sided ... Pkg. \$9.99
T 3 E 20614—Double sided ... Pkg. \$11.99

Certron double-density 3½-in. disks. Pkg. of 5. T 3 E 20610—Single sided. Wt. 3 oz ... Pkg. \$7.99
T 3 E 20611—Double sided. Wt. 5 oz ... Pkg. \$10.99

14 Commodore mouse for use with C64, 64C, and 128 computers. Warranted.** Imported. 3 E 32551—Wt. 1 lb ... \$39.99

Save \$50 to \$70 on computer combinations:

Computer (5) and monitor (2). Separate prices total \$799.98. 3 E 32221L—Wt. 53 lbs ... \$749.98

Computer (5), monitor (2) and printer (6). Separate prices total \$1019.97. 3 E 32222N—Wt. 71 lbs ... \$949.97

The children's
Discovery System™

A WARDS
**best
buy**

because Mattel's computer for
children is a total system
designed to develop learning
skills through the fun and
excitement of discovery—so
important to children 6 to 11!

Comparison Shopped for Value

99⁹⁸
Until Dec. 1 only

A The heart of the system is a child-sized, programmable computer—it's easy to use alone or with the supporting system of fun-learning modules (see below). Comes with a big Activity Book that offers over 100 projects. Learning skills are stimulated through the use of a multi-function keyboard, musical sound effects, animated viewing screen and 3 built-in modes for art; music; and one for vocabulary, spelling, writing skills. All modules are developed under consultation with educational experts. And, all modules may be used alone by the child or with a friend or parent.
48 TF 14300—Wt. 2 lbs. 8 oz. Until Dec. 1, 99.98
48 T 14300 After Dec. 1, 119.88

FUN-LEARNING MODULES: Includes pre-programmed cartridge, keyboard overlay and activity book. 01 Words I, 02 Music, 03 Art, 04 Words II, 05 Arcade, 06 Arcade II, and, a Wards exclusive—07 Memory and Logic. Ship. wt. 1 lb.
L 48 T 14301—State item no. each 20.99
SAVE \$2 ea. when you buy 3 or more . . . ea. 18.99
More learning toys pages 418, 431, 445.
Buy items B, C, D from facing page.



Call us this
Christmas.
It's fast
and easy!
See page 318.



1
Wildfire—
all the fun
and sounds of
real pinball
41⁹⁹



2
Split Second—
a race
against time
39⁷⁷



3
Strobe—
compete against
electronic ball
of sound and light
38⁹⁹



4
Fabulous
Fred—
10 games
in one
38⁸⁸

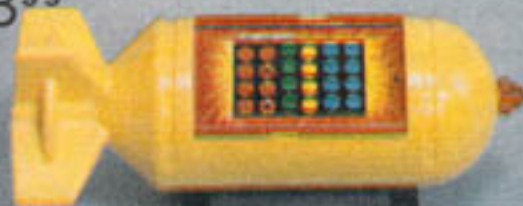

5 Can you
defuse it
before...
Le Boom!
31⁹⁹



6
Atomic Arcade
26⁹⁹
Tabletop pinball
battery operated

16½x10½x4 in. high



7
Microvision—
a complete
non-video
cartridge game
37⁸⁷
Includes
"Blockbuster" cartridge

Extra Cartridges
for [7]

15⁹⁹
Each

8

9

11

10

12



13
Merlin,
the Electronic
Wizard
28⁸⁸

14
Waddington's Wizard
32²⁹
4 games in one



15 Electronic Battleship **31⁹⁹**
22x11¼x5½ in. high



Intriguing Electronic Games You've Seen on TV!

1 Wildfire—Pinball Excitement in a Hand-Held Component. Lighted bumpers and targets. Pinball sounds loud or mute, LED digital scoring for up to 4 players and tilt. 3 adjustable speeds for testing skills. Uses 6 "AA" batteries. Warranted by mfr.—see page 363. Plastic. 7x9½x3 in. Ages 7 years and up. Will be \$44.99 on January 24, 1981. XU 923-4154 A—Del. wt. 1.10 lbs. NOW **41.99**

2 Split Second. 5 electronic action games: Auto Cross, Stomp, Space Attack, Mad Maze, Speedball. Each game is a fast race against time and all demand skill and dexterity. Digital scoring for 1 to 4 players. 7 years and up. Plastic. 9x9¾x2¾ in. high. Uses 6 "AA" batteries. Will be \$42.55 on January 24, 1981. XU 925-7767 A—Del. wt. 0.60 lb. NOW **39.77**

3 Strobe. Roll back the dome and compete in 3 accelerating action-and-reaction games, each with its own rhythm of lights and sounds. All demand skill and dexterity. Match Strobe's top speed and hear the victory tune. Electronic scoring for 1 to 4 players. 8 years and up. Plastic. 16½x16½x5 in. high. Uses one 9-volt and 2 "C" batteries. Will be \$41.69 on January 24, 1981. XU 925-7775 A—Del. wt. 2.50 lbs. NOW **38.99**

4 Fabulous Fred. 10 games demanding logic, skill, and memory: Music Machine, Name This Tune, Electronic Organ, Mind Bender, Memory Game, Submarine Chase, Catch the Comet, Baseball, Roulette, and Space Attack. 1 or more players, ages 8 and up. Plastic. 10½x7x2½ in. high. Uses one 9-volt and 2 "D" batteries. Will be \$39.88 on Jan. 24, 1981. XU 925-7791 A—Del. wt. 1.75 lbs. NOW **38.88**

5 Le Boom! Can you solve the correct number of coded buttons to defuse Le Boom in time? 4 difference fuse lengths with 4 skill levels. Ticking and real explosion sounds. 1 or more players. 8 years and up. Plastic. 13½x5½x5½ in. high. Uses 4 "D" batteries. Will be \$34.66 on Jan. 24, 1981. XU 925-7783 A—Del. wt. 2 lbs. NOW **31.99**

6 Atomic Arcade Tabletop Pinball Game. 5 power bumpers, rollover bumper, and digital scoring. Ages 6 years and up. Bells sound when a bumper is hit, and lights flash on scoreboard. Plastic. 16½x10½x4 in. high. Uses 5 "D" batteries. Will be \$28.99 on January 24, 1981. XU 923-3768 A—Del. wt. 4 lbs. NOW **26.99**

7 Electronic Microvision. Has its own miniature screen with easy-to-read display. 3 different skill levels. Includes "Blockbuster" game cartridge—knock down a wall, brick by brick. Order extra cartridges [8] to [12] below. Plastic. 10½x10½x2½ in. high. Uses two 9-volt batteries. One or more players. 8 years and up. Warranted by mfr. see page 363. Will be \$40.69 on January 24, 1981. XU 923-4170 A—Del. wt. 1.75 lbs. NOW **37.87**

8 to 12 Extra Microvision Game Cartridges for [7] above. Will be \$16.99 Jan. 24, 1981.

[8] **Sea Duel.** Warships versus submarines with torpedoes and depth charges. XU 925-7833 A—Del. wt. 0.50 lb. NOW **15.99**

[9] **Star Trek Phaser Strike.** You control speed and size of moving targets. XU 923-4238 A—Del. wt. 0.50 lb. NOW **15.99**

[10] **Baseball.** You control balls, and the runners. XU 925-7825 A—Del. wt. 0.50 lb. NOW **15.99**

[11] **Pinball.** Hit bumpers for points. XU 923-4253 A—Del. wt. 0.50 lb. NOW **15.99**

[12] **Bowling.** Strikes, spares. Adjustable ball speed. XU 923-4204 A—Del. wt. 0.50 lb. NOW **15.99**

13 Merlin, the Electronic Wizard. 6 games of strategy, logic, memory, and skill: Mind Bender, Tic Tac Toe, Echo, Blackjack 13, Magic Square, Music Machine—you can compose a tune of up to 48 notes. Ages 7 years and up. Plastic. 10x4x2¾ in. high. Uses 6 "AA" batteries. Will be \$30.88 on Jan. 24, 1981. XU 925-5431 A—Del. wt. 1 lb. NOW **28.88**

*Batteries not included—sold on page 461.



A

59.99-219.99

Computer workcenters organize all your hardware

A No money down, \$15 a month.* A modern workcenter with plenty of space for all your computer components. This deluxe all-wood computer desk comes complete with a 17x11½-inch monitor stand and storage area for software. It's finished in a beautiful light oak and the adjustable shelf lets you customize it to fit your computer needs. Makes a handsome addition to any home or office. 36 inches high x 24¼ inches deep x 27 inches wide. Unassembled.

63 G 13962 R—Ship. wt. 64 lbs. 219.99

B Computer work table offers plenty of space. It features a monitor platform and spacious pull-out drawer for holding software and other accessories. This unit accepts most keyboards, monitors, disk drives, printers and other computer accessories. Monitor platform measures 6x13x24 inches. Attractive hickory grain and dark brown vinyl laminates complement any office or home decor. Entire desk measures 32½ inches high x 23½ inches deep x 51¼ inches wide. Unassembled.

63 G 13920 R—Ship. wt. 106 lbs. 119.99

C Economical computer table is designed to accommodate most small computer systems. It has a compact design and features a removable monitor stand, storage compartment for software and accessories and a full modesty panel. Beautiful bartonwood vinyl laminate finish. Sturdy leg rails with bronze finish end caps. Monitor platform measures 6½ inches high x 9½ inches deep x 20 inches wide. Entire desk measures 25¼ inches high x 20 inches deep x 42 inches wide.

63 G 13921 R—Ship. wt. 58 lbs. 59.99

*Montgomery Ward Credit customers: This purchase may change your monthly payments depending on the highest balance on your account. Does not apply to AZ, NM and OR residents. See page 497.

530 • ALL



B



C

OUR LOWEST PRICE EVER for any daisy wheel electronic typewriter

\$169.99



IMAGINE, AN ELECTRONIC TYPEWRITER WITH TIME-SAVING FEATURES AND A GREAT LOW PRICE!

Dual pitch types in either 10 characters per inch (Pica) or 12 characters per inch (Elite). Full line correction automatically corrects any errors on the current line of type. Erase-a-word key corrects with a single touch, removes an entire word with just a tap of the key. Also features automatic carriage return, automatic centering (centers text between margins) and automatic relocate (after making a correction, returns to your next typing position in an instant). Second keyboard provides additional characters at your fingertips; also features half space, forward/reverse index and variable line spacing. All keys repeat. Includes carbon ribbon, lift-off correction tape and Daisy Wheel Regency 10, order extras at right. Warranted by Sears, write for copy, see page 371.

3 E 53002—Shpg. wt. 13 lbs. 8 oz. . . \$169.99

Carbon cassette ribbon. Wt. ea. 2 oz.
3 E 54140 . . . Each \$3.99
2 or more . . . Each \$3.59

Lift-off correction tape, pkg. of 2.
3 E 54141—Wt. pkg. 5 oz. . . Pkg. \$1.99
2 or more pkgs. . . Each \$1.79

Typewriter dustcover fits carriages up to 20 inches wide. Burgundy nylon quilted taffeta with black piping trim. Machine washable.
3 E 54020—Shipping weight 5 oz. . . \$9.99

Durable plastic daisy wheels in 3 type styles for use with electronic typewriter above.

Regency 10
Regency 12

Script 10/12

3 E 54144—Regency 10
3 E 54145—Regency 12
3 E 54146—Script 10/12
Wt. ea. 1 oz. . . Ea. \$11.99

SHOP BY PHONE
To order, call your local Sears store

Fisher-Price® Live, from Hollywood! It's showtime . . . and you're the star!



Mike stand
moves
around
with you

Push voice
pedal for
special echo
effects

Push light
pedal for
flashing
lights



1



Get a \$5 REBATE
from Fisher-Price!

3



Baby's first
sound system . . .
the Soft Sounds
tape player
mobile

4



5



6

7

1 Experience the fun of being onstage with the Star Stage performance center. Base includes amplifier with speaker, on/off and volume control knob. Microphone flex stand adjusts from 30 to 44 inches. Comes with handle for portability. Requires 4 "D" batteries sold separately on p. 406. Plastic. For ages 4 years and up. Warranted*. 49 N 66126—Wt. 6 lbs. 8 oz. . . \$39.99

2 A phonograph that really takes a beating . . . from its high-impact plastic body to solid-state circuitry to the constant-pressure tone arm that minimizes scratching, this record player is made for kids! Tone arm houses diamond needle and locks into place when case is closed. Plays 33½ or 45-RPM records. 4-in. speaker, on/off volume control. Uses AC power. Not recommended for ages under 4. Warranted*. 49 N 66601—Wt. 5 lbs. 2 oz. . . \$49.99

3 Use the hand-held microphone to record, sing along or announce the action. Portable cassette/recorder has easy-to-read, easy-to-use single-button controls. Headphone and AC jacks included. Low-battery LED indicator. High-impact plastic case. Requires 4 "C" batteries sold on page 406. Fisher-Price rebate coupon included with package†. For ages 3 years and up. Warranted*. Price after rebate \$44.99. 49 N 66088—Wt. 3 lbs. . . Full price \$49.99

†Item must be ordered by 12/31/88. Mail in completed Fisher-Price rebate coupon, postmarked by 1/15/89. Follow instructions included with item. Void where prohibited.

4 The Soft Sounds tape player mobile grows with your child all the way through toddler stage. Works with standard cassettes that Mom can make to put baby to sleep. Picture disk rotates while tape is playing. As your child grows older, he can change picture disks and tapes over and over again. Includes 3 picture disks and one blank 60-minute cassette. Requires 4 "C" batteries sold on p. 406. High-impact plastic case. For newborns and up. Warranted*. 49 N 66488—Wt. 1 lb. 13 oz. . . \$49.99

PXL 2000 camcorder Save \$110

5 Hey kids, make your own videos! The PXL 2000 Deluxe is the only camcorder system designed especially for kids! Dynamic camera records a unique black and white image called Pixelvision®, with sound, on a regular high-bias audio cassette. Lightweight unit has simple one-button operation, pre-set focus and sound level. Features a built-in microphone, automatic light adjustment for indoor or outdoor use, and the eyepiece allows right or left-handed use. Comes with its own special 4.5-inch black and white TV with AC adapter, high-bias audio cassette and action strap with clip-on harness to hold camera. Action strap has extra storage for batteries and cassettes and can be used as a belt or shoulder strap. Requires 6 "AA" alkaline batteries, included. Not recommended for ages under 8. Warranted*. Was \$279.99 in our 1988 Spring General. 49 N 66462—Wt. 9 lbs. 4 oz. . . Now \$169.99

6 Tapes for use with Camcorder. When used with the PXL 2000, these high-bias 90-min. audio tapes each provide 11 minutes of recorded black and white video and audio. Set of 4. 49 N 66498—Wt. 11 oz. . . Set \$9.99

7 PXL 2000 carrying case is designed for protecting and storing the PXL 2000. Soft-shell case includes storage for tapes and all TV hookup accessories. Nylon exterior. 49 N 66455—Wt. 9 oz. . . \$19.99

*Warranted by Fisher-Price; write for free copy, see page 304.

Sears Land is a toy store
that really cares about
YOU . . . see page 344



Electronic playmates make math and spelling fun to learn

A Quiz Kid Racer helps children 6 years old and up develop math skills. Thousands of pre-programmed 10-question problems in the 4 functions. Pro-key increases level of difficulty, complex key creates missing number problems (for example: $3 + ? = 9$). After each successful answer, the child is rewarded with a Green light. Slow and fast keys adjust the speed to each child's personal learning rate. Uses one 9-volt battery (sold separately on Page 335), or household current with AC adapter sold below. About $6 \times 3 \times 1\frac{1}{2}$ " 8 oz.

032 531 026 - Each 17.99

AC Adapter for use with 'A' and 'E'

032 541 088 - Each 4.99

B Little Professor - a fun way for children 5 years old and up to practice basic arithmetic. When a problem is shown on the illuminated display, the child has three chances to solve it before the Little Professor gives the correct answer. After 10 problems, the score is given. Thousands of problems in 4 skill levels. Includes 'Fun with Math Facts' book, filled with learning games and activities. Uses one 9-volt battery (sold separately on P. 335). About $5 \times 3\frac{1}{2} \times 1\frac{1}{4}$ " 13 oz.

032 531 050 - Each 17.99

C Quiz Kid. An extremely inexpensive unit that helps teach arithmetic to children 5 years old and up, and checks their homework too! First, they enter the problem, (for example: $3 + 3 = ?$), and the answer (6). Then they ask the Quiz Kid if their answer is correct by pressing the ? key. Correct answers light up Owl's Green eye, while incorrect answers light up his Red eye. Comes with a big 33-page Quiz book of math puzzles, games and problems. Uses one 9-volt battery (sold separately on Page 335). About $5 \times 3 \times 1\frac{1}{4}$ " 8 oz.

032 531 025 - Each 9.99

D Speak and Spell - the amazing talking machine from Texas Instruments. For children 7 years old and up. The electronic voice pronounces a word for the student, who then keys in the spelling. It announces whether the spelling is right or wrong, and displays and tells the score. Four levels of difficulty, each with 50 words that are often misspelled (plus the machine accepts plug-in modules, like 'Vowel Power' sold below, that add new words to the program). Easy-to-follow book of instructions and activities. Uses four 'C' batteries (sold separately on P. 335). About $10 \times 7 \times 1\frac{1}{4}$ " 16 oz.

032 531 051 - Operates in English only. Each 74.99

'Vowel Power' Word Expansion Module - plugs into 'Speak and Spell' and instantly adds 140 new English language words to the machine's basic list.

032 531 060 - Each 19.99

E Speller. This unique learning aid uses word-picture association to improve spelling skills. Children 3 years old and up will enjoy the Speller. In the Spell mode, it displays a number corresponding to a picture in the Quiz book and the kid keys in the spelling. In the Learn mode, pre-schoolers key in just the first letter. A Green light glows for correct answers, a Red one for incorrect answers. Players get five points when they are right on the first try, 3 on the second, 1 on the third. The score is totalled up at the end of each series. The Game mode adds to the fun. Speller comes with word/picture association book of 99 numbered pictures. Uses four 'AA' batteries (sold separately on Page 335), or household current with AC adapter sold above. About $5\frac{7}{8} \times 3\frac{1}{4} \times 1\frac{1}{2}$ " 11 oz. Operates in English only.

032 531 027 - Each 24.99



A 17.99

B 17.99



Life-like electronic voice helps teach spelling!

C 9.99

D 74.99



E 24.99

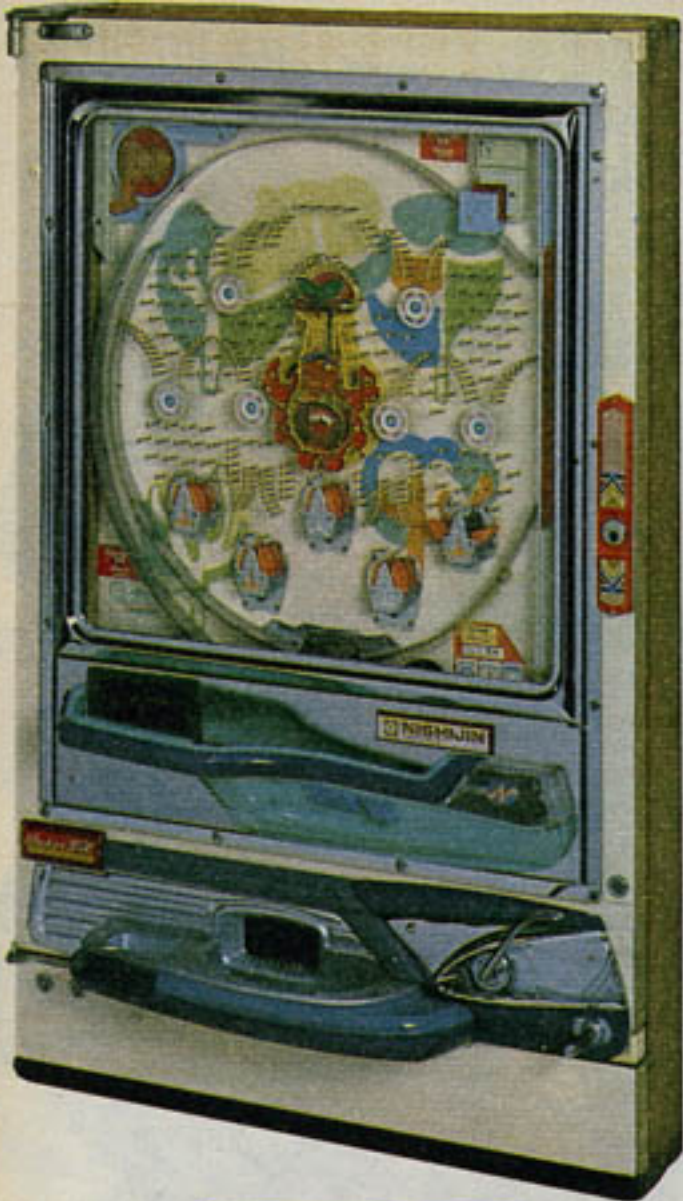

From authentic Pachinko Parlors . . .
**Reconditioned Pachinko
 Pinball Machines**

An upright version of pinball
 to enliven your den or game room

Simply flip a lever to send a steel ball racing through wheels and a maze of bright, shiny pins. Each time you hit a jackpot, bells ring and you receive 15 extra playing balls. CONSTRUCTION: Machine from authentic Pachinko Parlors . . . each is cleaned, lubricated and reconditioned. Colorful faces may vary in design because each machine is an original. Unfinished wood frame with attached stand. Ash-tray. 300 steel balls. Measures 32x20½x9 inches overall. Imported.

ORDERING INFORMATION: Order extra balls below.
 Shipping weight 42 pounds.
 3 C 2990L \$54.99
 200 extra steel Balls
 3 C 2984—Shipping weight 2 lbs. 6 oz. Pkg. \$5.99
 2 or more packages Each Package 5.49

Phone ordering's a quick and easy way to buy.

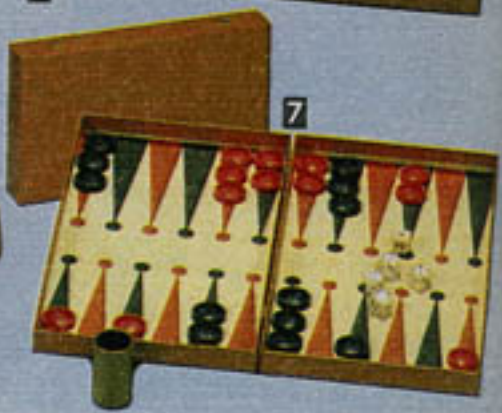
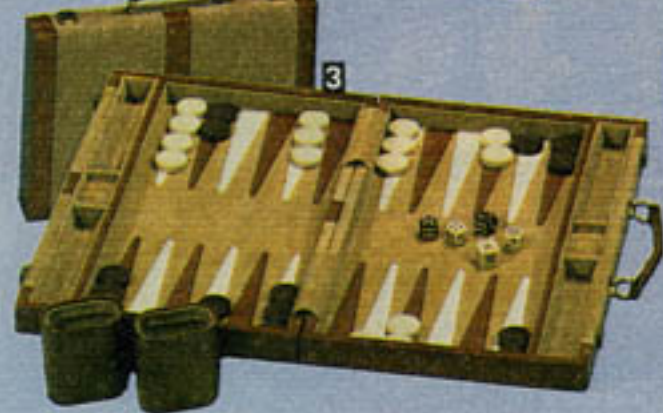
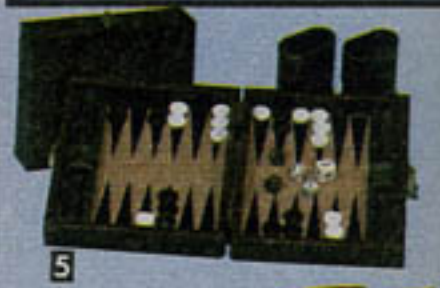
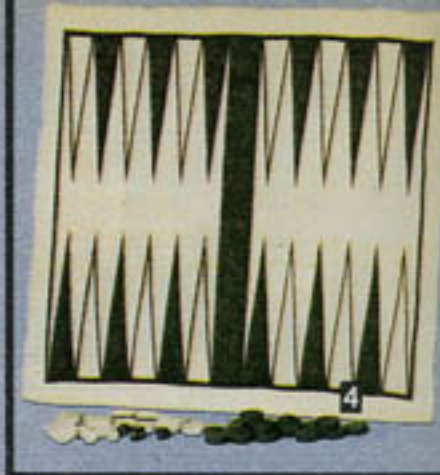

Tests of skill and strategy
 for everyone in the family . . . **BACKGAMMON,**

(1) Our finest Backgammon Set with genuine leather case
 CASE, BOARD: Genuine leather-covered case. Rich stitched patchwork in a random design. Large 15½x14½-inch playing field of stitched leather on cotton velvet. Leather carrying case and brass hardware. Imported.
 PIECES: 30 plastic playing pieces, 4 dice; two leather dice cups; doubling cube; instructions.
 ORDERING INFORMATION:
 Shipping weight 5 pounds.
 3 C 2822 Set \$36.99

(2) Plaid Backgammon Set
 CASE, BOARD: Rich brown plaid case. 15½x14½-inch playing field of cotton felt with stitched points. Carrying handle and brass hardware.
 PIECES: 30 plastic playing pieces; 4 dice; doubling cube; two leatherette (not leather) dice cups; instructions. Imported.
 ORDERING INFORMATION:
 Shipping weight 5 pounds.
 3 C 2947 Set \$27.99

(3) Suedette Backgammon Set
 CASE, BOARD: Padded suedette fabric (not suede) case. 15½x14½-inch playing field of cotton felt with stitched points. Carrying handle and brass hardware.
 PIECES: 30 plastic playing pieces; 4 dice; doubling cube; two suedette fabric dice cups; instructions. Imported.
 ORDERING INFORMATION:
 Shipping weight 4 pounds.
 3 C 2876 Set \$19.99

(4) Backgammon on a rug
 RUG: Brown and white with velvet-like pile, 100% DuPont Orion® acrylic. Measures 27x24 in. overall.
 PIECES: 30 hardwood pieces, 1½-inch in diameter, stained with a natural dark or light finish; 2 sets of dice; doubling cube; instructions.
 ORDERING INFORMATION:
 Shipping weight 3 pounds.
 3 C 2890 Set \$9.99

(5) Magnetic Backgammon Set
 CASE, BOARD: Padded leatherette (not leather) case. 8½x10-inch metal and plastic playing field. Brass hardware. Imported.
 PIECES: 30 magnetized and felted playing pieces; 4 dice; doubler; cotton felt-lined dice cups; instru.
 ORDERING INFORMATION:
 3 C 2963—Shpg. wt. 1 lb. 10 oz. Set \$7.49

(6) Backgammon Set with vinyl case
 CASE, BOARD: Padded vinyl case with contrasting stripe. 15x14-inch playing field of cotton felt with stitched points. Handle, brass hardware.
 PIECES: 30 plastic playing pieces; two cotton felt-lined dice cups; 4 dice; doubling cube; instructions.
 ORDERING INFORMATION:
 Shipping weight 5 pounds.
 3 C 2907 Set \$15.99

(7) Backgammon Teachers Set
 CASE, BOARD: Hardboard folding case opens to 16x14-inch simulated cork playing field.
 PIECES: 30 plastic pieces; four dice; doubling cube; dice cup. Also, 170-page history/instruction book on backgammon by Prince Obolensky.
 ORDERING INFORMATION:
 Shipping weight 2 pounds 4 ounces.
 3 C 29274 Set \$8.49

Growing up smart



Quiz-a-tron teaches basic skills needed to understand math, logic, words, shapes, colors and more

A 380-question booklet and electronic speed control quizzes children and encourages them with lights and sounds to select the correct answer. 3 speed settings for learning at challenging paces. Booklet with examples of 4 levels has 38 pages. Extra booklets sold below. Plastic. 10½x2x7¼ in. wide. Imported. Uses 8 "AA" batteries, not included, sold on facing page.

For ages 4 to 8 years
49 C 1779—Shipping weight 1 pound 12 ounces\$24.99

Extra Question Booklets. Each 38 page booklet has 380 questions to challenge 4 to 8 year olds.
49 C 17796—Level I, ages 4 to 5 yrs. 49 C 17798—Level III, ages 6 to 7 yrs.
49 C 17797—Level II, ages 5 to 6 yrs. 49 C 17799—Level IV, ages 7 to 8 yrs.
Shipping weight 8 ounces Each \$2.99

Save \$2 when you buy all 4 booklets listed above
49 C 17789—Shipping weight 2 pounds Separate prices total \$11.96, \$9.96



1

Items (2 thru 4)
\$10 REBATE from
Texas Instruments



2



3



4



ONLY AT SEARS

1 Crestwood® Pool Table
84.99



5
29.99



6 22.99 less legs



7 Stanley Cup Game
15.99



2 Champ® Pool Table
31.99



8 Crokinole/Checkers Game
15.99



Reverse side



3 Sky Bolt Pinball
44.99

4 Save \$3
17.99

ONLY AT SEARS



9 LAZER Light Star
39.99

Sears Video Arcade™ Cartridge System

These Cartridges reprogram the Video Arcade Console (sold on preceding page) to give you a new set of games



For 1 or 2 players . . .
6 playfields for 19 games

Test your ability to remember sequences, add numbers, find dissimilar objects within the time allotted, or play simple tunes.

ORDERING INFO: Must be played with Keyboard Controls 6 C 99834 sold on page 651.
6 C 99818—Shipping weight 4 oz. . . . \$19.95



For 1 to 3 players . . .
House plays with full 52-card deck

Play against "the house" using Las Vegas odds and rules. Start with 200 points, game ends when you win 1000 points or house "breaks" you to 0.

ORDERING INFO: For 3 players order Extra Paddle Controls 6 C 99831 sold on page 651.
6 C 99805—Shipping weight 4 oz. . . . \$19.95



For 1 or 2 players . . .
1 against computer or 2 in timed "one-on-one"

Your player dribbles down court, shoots, steals the ball, or even blocks an opponents shot. 3-dimensional court. 4-minute clock times action, player with the most points wins the game.

ORDERING INFO: Uses joystick controls.
6 C 99826—Shipping weight 4 oz. . . . \$19.95



For 1 or 2 players . . .
2 playfields for 20 games

The computer or your opponent enters a numerical code ranging from easy to almost impossible. You try to crack it by guessing and reasoning in 10 or 13 tries.

ORDERING INFO: Must be played with Keyboard Controls 6 C 99834 sold on page 651.
6 C 99815—Shipping weight 4 oz. . . . \$19.95

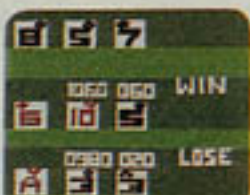

For 1 to 4 players . . .
3 playfields for 24 games

Play five-card stud poker for 1-4 players; poker solitaire for 1; play blackjack with card splitting for 1-2, without splitting for 1-4.

ORDERING INFORMATION: For use by 3 or 4 players, order Extra Paddle Controls 6 C 99831 sold on page 651.
6 C 99816—Shipping weight 4 oz. . . . \$24.95



For 2 players . . .
4 playfields for 9 games

Your missile-firing car weaves in and out of simple or complex mazes pursuing your opponent. Speed up, fire missiles around corners, duck into an opening to avoid being hit. 25 hits end game.

ORDERING INFO: Uses joystick controls.
6 C 99825—Shipping weight 4 oz. . . . \$19.95



For 1 or 2 players . . .
2 playfields for 8 games

Field has 16 or 32 squares hiding a variety of matching pictures. Select squares to match the pictures for points, even adding 1 or 2 wild cards.

ORDER INFO: Game must be played with Keyboard Controls 6 C 99834, sold on pg. 651.
6 C 99814—Shipping weight 4 oz. . . . \$19.95



For 1 to 4 players . . .
6 playfields, 27 games, score to 99 points

Race through traffic against the clock, scoring points for passing cars, losing points for crashes. Or over bridges, ski slope, fly planes.

ORDERING INFORMATION: For use by 3 or 4 players order Extra Paddle Controls 6 C 99831 sold on page 651.
6 C 99804—Shipping weight 4 oz. . . . \$19.95



For 1 player . . .
1 playfield, 8 games choice of time limit

Work a series of 10 base number or random problems flashed on screen. The correct answer is rewarded with musical tone; if you are wrong, correct answer appears. Final score appears when series is over.

ORDERING INFO: Uses joystick control.
6 C 99808—Shipping weight 4 oz. . . . \$19.95



For 1 to 4 players . . .
7 playfields for 50 games, scored to 21

Fast-action volleying with automatic or manual ball speed-up. Includes Pong, Super Pong, Tennis, Soccer, Hockey, Volleyball and Basketball.

ORDERING INFO: For 3, 4 players order Extra Paddle Controls 6 C 99831 sold on page 651.
6 C 99806—Shipping weight 4 oz. . . . \$19.95



For 1 or 2 players . . .
2 playfields for 8 games

Bomb a canyon filled with bricks or drop depth charges in the sea and explode them. Choose unlimited bombs or 6 misses; points scored can vary with value of bricks or depth of charges.

ORDERING INFO: Uses paddle controls.
6 C 99828—Shipping weight 4 oz. . . . \$19.95



For 1 or 2 players . . .
1 playfield for 9 games, timed option

Guess the letters that spell the word chosen by computer or opponent. Correct guesses rewarded by musical tone; 11 wrong guesses outline monkey on screen, computer shows word. Choice of 4 different vocabulary levels.

ORDERING INFO: Uses joystick controls.
6 C 99811—Shipping weight 4 oz. . . . \$19.95



For 1 to 4 players . . .
3 playfields for 12 games, with timed option

Compete to break down a wall of bricks, each row having different point total. Break back wall then touch top of screen and ball speeds up.

ORDERING INFO: For 3, 4 players order Extra Paddle Controls 6 C 99831 sold on page 651.
6 C 99813—Shipping weight 4 oz. . . . \$19.95



For 1 or 2 players . . .
1 playfield for 8 games to 9 innings

Play against human or robot opponent. "Pitcher" controls ball speed and direction; "Batter" swings for long drive or bunt then races to first base. Field the ball, then tag runner for out. On-screen scoring.

ORDERING INFO: Uses joystick controls.
6 C 99819—Shipping weight 4 oz. . . . \$19.95



For 1 player . . .
on-screen timer

Help Superman race scene to scene against time to put Lex Luthor in jail, rebuild exploded bridge, and report back to the Daily Planet as Clark Kent while avoiding Kryptonite satellites.

ORDERING INFO: Uses joystick control.
6 C 99845—Shipping weight 4 oz. . . . \$24.95

MATTEL



A
Football 2
32⁸⁸



B Baseball 32⁸⁸



C Basketball 2 32⁸⁸



E Soccer 28⁷⁷



F Auto Race 23⁹⁹



D Hockey 28⁷⁷



G
Kenner Live Action
Football
45⁷⁷

Hand-Held Electronic Games

- Game action and LED readout for time remaining and scoring
- Built-in screen—no TV needed
- Warranted by manufacturer, see p. 363

A Mattel's Football 2. 4 quarters of play, victory, charge, and ref's whistle sounds. 2 skill levels with 4 playing speeds. Plastic, 4⁷/₈x2¹/₄x7¹/₈ in. Uses one 9-volt battery*. For 1 or 2 players, ages 8 and up. Will be \$34.99 on Jan. 24, 1981.
XU 917-3717 A—Del. wt. 0.50 lb.NOW 32.88

B Mattel Baseball. You control the batter and runner, computer controls pitcher and fielders. Baseball sounds. Two skill levels. Plastic, 4⁷/₈x2¹/₄x7¹/₈ in. Uses one 9-volt battery*. For 1 or 2 players, ages 8 and up. Will be \$34.99 on Jan. 24, 1981.
XU 917-3543 A—Del. wt. 0.50 lb.NOW 32.88

C Mattel Basketball 2. Has 2-man offense, 3 types of defense. Fouls, foul shots, passing, 3-second violations, 3-point play. Ref's whistle for fouls and turnovers, victory sound for baskets, buzzer at game end. 2 skill levels, 4 playing speeds. Plastic, 4³/₄x6³/₄x1¹/₂ in. Uses one 9-volt battery*. For 1 or 2 players, ages 8 and up. Will be \$34.99 on Jan. 24, 1981.
XU 924-9715 A—Del. wt. 0.40 lb.NOW 32.88

D Mattel Hockey. You control the puck. Sounds for penalties, turnovers, goals. Plastic, 4¹/₂x6¹/₂x1¹/₂ in. Uses one 9-volt battery*. 2 skill levels for 1 or 2 players, ages 8 and up.
XU 924-9814 A—Delivery weight 0.40 lb.28.77

E Mattel Soccer. You control the ball. Special sounds for turnover, goals. 2 skill levels. Plastic, 4¹/₂x6¹/₂x1¹/₂ in. Uses one 9-volt battery*. For 1 or 2 players, ages 8 and up.
XU 924-9731 A—Delivery weight 0.40 lb.28.77

F Mattel Auto Race. Race against time. Collide and lose time and points. Three lanes, 4 laps, sounds for race car motor. Plastic, 3x5x1 in. Uses one 9-volt battery*. For 1 or more players, ages 8 and up.
XU 917-2180 A—Delivery weight 0.50 lb.23.99

G Kenner Live Action Football. Play against the computer or another player. Offensive and defensive animated figures. Pass, punt, tackle, and extra point. Authentic football sounds. Plastic, 7¹/₂x8x2 in. high. Uses 6 "AA" batteries*. Ages 8 and up. Will be \$49.99 on January 24, 1981.
XU 923-9864 A—Del. wt. 1.50 lbs.NOW 45.77

H Coleco Head-to-Head Football. Play against the computer or another player. Offensive pass, block, run, kick; defensive intercept, blitz, tackle. Ref's whistle sound, and cheers on scoring. 2 skill levels. Plastic, 9¹/₂x3³/₄x1¹/₄ in. Uses one 9-volt battery*. Ages 8 and up.
XU 923-9914 A—Delivery weight 0.70 lb.35.99

I Coleco Head-to-Head Basketball. Play against the computer or another player. Pass, block, aim, shoot, and rebound. Electronic sounds; 2 skill levels. Plastic, 9¹/₄x3³/₄x1¹/₄ in. Uses one 9-volt battery*. Ages 8 and up.
XU 923-9963 A—Delivery weight 0.70 lb.35.99

J Coleco Head-to-Head Hockey. Play against the computer or another player. Pass, block, shoot, has rebound, too. 2 skill levels. Plastic, 3³/₄x9¹/₄x1¹/₄ in. Uses one 9-volt battery*. Ages 8 and up.
XU 917-3725 A—Delivery weight 0.80 lb.35.99

K Coleco Head-to-Head Baseball. Play against computer or another player. Scoreboard displays all statistics plus batter's average and result of each hit. 16 pitch variations, 2 skill levels. Electronic sounds include "Take Me Out to the Ball Game." Plastic, 9³/₄x8³/₄x2³/₄ in. high. Uses two 9-volt batteries*. 1 or 2 players, ages 8 and up.
XU 923-9922 A—Delivery weight 1 lb.35.99

L Coleco Electronic Quarterback. Block, pass, run, kick. Referee's whistle; victory tune on touchdowns. 2 skill levels. Plastic, 7x4x1 in. Uses one 9-volt battery*. For 1 or 2 players, ages 8 and up.
XU 917-3071 A—Delivery weight 0.50 lb.26.99
*Batteries not included, sold on page 461.

COLECO



H
Head-to-Head
Football
35⁹⁹



I
Head-to-Head
Basketball
35⁹⁹



J
Head-to-Head
Hockey
35⁹⁹



K
Head-to-Head
Baseball
35⁹⁹



L
Electronic
Quarterback
26⁹⁹

First the cords went... now the size goes, too!

Enjoy 2-way conversations or paging without having to dial a number using the compact Nomad* 600

Direct communications between the handset and the base unit are possible with the built-in base unit intercom. Two-way paging system allows a beep tone to be sent from base to handset (and vice versa) signaling the party on the other end.

The pocket-sized handset offers you a 700-foot operating range. Features a pushbutton dial pad, automatic redial button (which can be programmed for one-button dialing of a particular phone number), hi/low volume control, electronic ringer and low battery warning light. 5 1/4 x 1 7/8 x 2 1/4 in. Operates on rechargeable battery (included). Operating range may vary from distance specified depending on local conditions.

The base unit features a built-in security system. System prevents anyone with another cordless telephone from using your phone line whenever your handset is placed into the cradle. Unit also acts as a storage and recharging station for the handset. Plugs into any modular phone jack and AC electrical outlet. UL listed. 110-120-volt, 60 Hz. AC. 7-foot power cord. Measures 6 3/4 x 2 1/4 x 7 7/8 inches. Warranted by American Bell; write for your free copy, see page 323. See Installation Note on page 393.

3 E 24068C—Shipping weight 2 pounds\$199.99
*Trademark of AT&T



Keep other cordless phones off your line with the dual security systems of the pocket-sized EX-2600

This compact cordless telephone prevents unauthorized access to your phone line with two separate built-in security systems... one in the handset, the other in the base unit. The switchable guard tone system of the handset allows you to selectively lock your phone into your choice of two guard tones, creating your own private channel. The base unit AutoSecure™ system activates automatically whenever the handset is placed into the cradle.

The handset folds up to pocket size. Offers you a 700-foot operating range and features touch-sensitive keypad, one-button automatic redial plus ringer volume control. Measures 5 1/4 x 1 1/8 x 2 1/4 in. Operates on rechargeable battery (included). Operating range may vary from distance specified depending on local conditions.

Base unit's 1-way paging system sends beep tone to alert the handset user. The unit also acts as a storage and recharging station for the handset. Measures 5 1/2 x 2 3/4 x 9 1/2 inches. Plugs into modular phone jack and AC electrical outlet. UL listed. 110-120-volt 60 Hz. AC. 5 1/2-foot power cord. Warranted by Uniden; write for your free copy, see page 323. See Installation Note on page 393.

3 E 3404C—Shipping weight 1 pound\$179.99



Start your own cordless network!

MURAPHONE®

The MP-800/801 system begins with a multi-function desk phone (which also serves as a base station for up to 5 cordless handsets) plus a remote cordless handset with a range of up to 1000 feet (depending on conditions).

Thanks for the 32 memories. Store up to 32 of your most frequently-called numbers, or MCI and bank authorization codes, and dial them from memory—from either the desk unit or the cordless handset—on a simple one-button command. A synthesized voice talks you through memory programming and operation and also recites, either singly or in sequential order, any numbers stored in memory.

Station-to-station-to-station-to-station-to-station. Full duplex 5-channel intercom system enables direct communications with any individual handset (without the others hearing) or up to 5 handsets simultaneously. While on the intercom, if an outside call comes in, you can put either party on hold, so you can talk to whichever party you choose in total privacy.

A security code you can call your very own. To prevent unauthorized access to your cordless phone line, you can choose from over 4000 possible 4-digit security code combinations (for each of the 5 channels), creating private channels that shut out all other cordless phones. The desk unit, which also features automatic and manual switching from rotary to true tone dialing, plugs into any modular phone jack and AC electrical outlet. UL listed. 110-120-volt 60 Hz. AC. 6-ft. power cord. Remote handset operates on rechargeable batteries (batteries and recharger included). See note below.

3 E 3433C—Shipping weight 5 pounds 12 ounces\$219.99

Note: Additional remote handsets may be purchased directly from the manufacturer. An order blank with complete ordering instructions is included with each system. Warranted by Muraphone/Technicom International, Inc.; for free copy, see p. 323. See Installation Note on p. 393.



Night Rescue Chutes Away.* You've got just your trusty searchlight, and a reduction-lens peep-sight to master the dark. Your mission: drop supply chutes to disaster victims. Use control lever to position plane, push lever to drop a chute. If it hits a target area, you score. 16 1/4 in.-diameter wind-up turntable, 16 in. high. Plastic. Built-in searchlight uses 2 "AA" batteries—not included, sold on page 461. For ages 5 and up. XU 924-5978 A—Delivery weight 4.60 lbs 19.39



Night Rescue Chutes Away 19³⁹



Lay an Egg 9³⁸

Lay an Egg. The hopping hen circles the board. When a player presses the button, she lays an egg that rolls into a player's bin. Only good timing gets that egg into the right bin. Player who gets the most eggs, wins. Plastic. 15 1/4 x 9 1/4 x 3 1/4 in. high. Uses one "D" battery—not included, sold on p. 461. For 2 to 4 players, ages 5 and up. XU 925-9474 A—Delivery weight 2.25 lbs 9.38



1 Scat Cat 9²⁹



2 Beware the Spider 9⁵⁹

2 Beware the Spider. Pick those yucky bugs out of the spider's web. But beware! If your metal fork touches his web, he'll leap from his perch to protect his lair. Get caught, and you lose. Uses 2 "C" batteries—not included, sold on page 461. Includes 7 plastic critters, 1 polyurethane foam spider, 12x8 1/2 x 2 1/4 in.-high plastic board. For 1 or more players, ages 6 and up. XU 924-6091 A—Delivery weight 1.85 lbs 9.59



3 Pit 'N' Pendulum 9⁹⁹

3 Pit 'N' Pendulum.* The pendulum swings back and forth, as the two players try to get the bones out of the hole on their side of the column, and into the coffin. It's a challenge because the coffin lid descends as you remove the bones. Player who gets the most bones in the coffin before the lid shuts tight, wins. Plastic. 9x6x15 in. high. For 2 players, ages 5 and up. XU 924-6117 A—Delivery weight 2 lbs 9.99

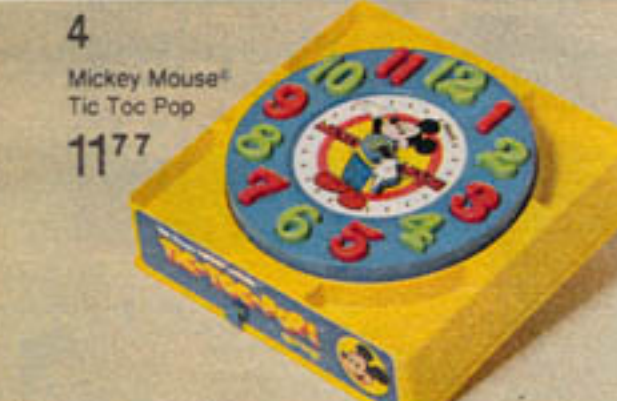

4 Mickey Mouse® Tic Toc Pop 11⁷⁷



5 Mr. Mouth 8⁵⁹

5 Mr. Mouth. Try to flip chips into his open lips. It doesn't take too much skill because Mr. Mouth can hardly keep his big mouth shut. First player to flip in all his chips, wins. Plastic. 17 in. diameter, 5 in. high. Uses one "C" battery—not included, sold on page 461. For 2 to 4 players, ages 5 and up. XU 924-8857 A—Delivery weight 1.20 lbs 8.59



6 Funny Football 4⁹⁵ Each



7 Strolling Bowling

4 Mickey Mouse® Tic Toc Pop. Set the numbers in the right places on the clock face before the time runs out. Hurry! If you don't finish in time, the numbers jump up in the air! Helps teach hand-eye coordination, and how to tell time. Plastic. 10 1/2 x 10 1/2 x 2 1/2 in. high. Ages 3 and up. XU 923-0277 A—Delivery weight 2 lbs 11.77

*Walt Disney Productions. See special Disney index on page 371.

6 & 7 Portable, Sportable Fun. Wind-up action kids can play anywhere. Plastic. 6 1/4 x 6 x 2 1/4 in. high each. For ages 5 and up.

[6] Funny Football. Place the football on the fifty-yard line, wind up the two players, and see which one gets the ball across his goal line first. Extra football included. XU 924-5994 A—Delivery weight 2 lbs 4.95

[7] Strolling Bowling. Wind-up little bowling ball hops down the lane, and knocks the pins over. XU 924-6042 A—Delivery weight 2 lbs 4.95

8 X-4 Bomber. Looks alot like pinball, but with a big difference! Just set the timer and the screen lights up with ships, and your soaring X-4 Bomber. Bombs are really falling lights—hit a ship and it "capsizes" and gives you a score. Plastic. 9x4 1/4 x 13 1/4 in. high. Uses 2 "C" batteries—not included, sold p. 461. For ages 5 and up. XU 924-6125 A—Delivery weight 3 lbs 16.99



8 X-4 Bomber 16⁹⁹



9 Bop Bop 'N' Rebop 12⁴⁹

9 Bop Bop 'N' Rebop. Try to keep the bounding puck out of your goal. It isn't easy because the rotating turntable keeps the puck flying. Three goals and you lose. Plastic. 17 1/2 in. diameter, 3 1/4 in. high. Uses 2 "D" batteries—not included, sold on page 461. For 2 to 4 players, ages 5 and up. XU 925-1745 A—Delivery weight 3.25 lbs 12.49

TOYS AREN'T JUST FOR CHRISTMAS. Save this catalog. Order toys from pages 375-527 until August 15, 1981.

Introducing
a new game
from

Sears

TELE-GAMES™
ELECTRONIC GAMES

Fast-paced games
you play on your own TV

Designed for Sears by Atari—
one of the leading makers
of electronic games

Wish Book
value

"Pong" TV Table Tennis
with all the action and sound
you find in commercial games
costing hundreds of dollars more

An outstanding
low price . . . only

\$98⁹⁵

Tap action button to start the game, then twist knob on control panel to make your "paddle" dash vertically and smack the "ball" back to your opponent. Quick, easy hook-up . . . just attach antenna change-over switch to VHF antenna terminals, plug 15-foot cable from control panel into change-over switch and tune in channel 3 or 4. Works with any size black-and-white or color TV. Four "D" batteries included. High-impact control panel 10½x5½x4¼ inches high. TV not included.

6 C 25796C—Shipping weight 5 pounds **\$98.95**

AC Power Adapter. Converts 120-v. household current to low DC voltage. UL listed. 110-120 volts, 8 watts, 60 Hz. AC. Includes twenty-foot cord.

6 C 25792—Shipping weight 1 pound **\$7.95**

FULL ONE YEAR WARRANTY: For one year from date of purchase, we will repair "Pong" TV electro-video game if it fails due to a defect in materials or workmanship. This warranty service is available by simply contacting your nearest Sears store or Service Center throughout the United States.

**ACTION SPEEDS UP
AUTOMATICALLY**

After 4th and 8th volley,
the speed of the "ball"
increases automatically
to challenge your skill

BEEP

BEEP

**SCORE SHOWS UP
ELECTRONICALLY**

Scores from 1 to 15 flash
on screen after each point
. . . and in color (if you
have a color TV set)

**YOU HEAR THE
SOUND OF ACTION**

Every time electronic "ball"
hits "paddle" or sideline,
you hear a beep

**RELIABLE
SOLID-STATE CONTROLS**

Each player controls
"paddle". Console
uses little power—
operates on low-cost,
low-drain batteries



1 Two-in-One Rider/Wagon
2299



Star Rider
5999



B-BROOM
WARP
ZAP

Star Rider. Control console and chassis rotate 360°; chassis makes ratchet sound. Controls include "engine" start button; volume button to simulate speed sound; power button to oscillate sounds; alarm button for siren and flashing lights; laser button for firing light on screen; detonator for exploding flashes and sounds; rocket booster for piercing acceleration noise. Plastic. 16x30x21½ in. high. Uses one 9-volt and 2 "D" batteries—not included, sold on page 461. Assembly required. For ages 3 to about 9 years. XU 923-4857 A—Delivery weight 15 lbs. 59.99



2 Sit 'N' Spin
1484



3 Sit 'N' Drive
1099



1 Riding Wagon. It's two riding toys in one. With handles and sides up it's a ride-on, with them down it's a wagon. Big, smooth-running wheels make a ratchet sound. Plastic with steel axles. 20 in. long when handle is up. For ages 1½ to 4 years old. Will be \$23.99 on January 24, 1981. XU 925-8377 A—Del. wt. 6 lbs. NOW 22.99

2 Sit 'N' Spin. Go round and round like a merry-go-round. Toddlers turn the wheel and spin around at their own speed. 18-in. diameter seat. Sturdy plastic in red or blue (sorry, no color choice). 18 in. high. Assembly required. For ages 1½ to about 5 years old. Will be \$15.88 on January 24, 1981. XU 925-1273 A—Del. wt. 6.50 lbs. NOW 14.84

3 Sit 'N' Drive puts tots in the driver's seat. A car-look—dashboard with a horn that toots, a steering wheel that turns, a movable stick shift, a side-view mirror, a play radio, and an ignition key that turns. Plastic. 15x14½x8¼ in. high. Fully assembled. Ages 1 to about 3. XU 923-4873 A—Delivery weight 3 lbs. 10.99

4 Creative Coaster. A ride-on, push or pull storage wagon. 18 plastic blocks, 6 wooden dowels. Pushbutton horn "beeps" and wheels "clickity-clack". Wood and plastic. 19½x11¼x16¼ in. high overall. Ages 1 to about 3 years. XU 923-9575 A—Delivery weight 7 lbs. 17.99

1799



4

516 JCPenney

5
1577



TOOT
TOOT

1599

6



CLICK
CLICK

Converts from walker to ride-on

5 Toddlin' Train. Tots move the lovable loco forward, and the "engine" makes a toot-toot sound as the face on front moves in and out. Bright plastic. 18½x10½x12 in. high. Great as a walker or ride-on toy. Assembly required. Ages 1½ to about 3. XU 923-4840 A—Delivery weight 8 lbs. 15.77

6 Chicken to Go. This liling Leghorn bobs his head, clucks, even blinks his eyes as he moves along. Rear push bar for tots who are learning to walk. Plastic. 10x16x16 in. high. Fully assembled. For ages 1½ to about 3½ years. XU 925-8385 A—Delivery weight 6 lbs. 15.99

TOYS AREN'T JUST FOR CHRISTMAS. Save this catalog. Order toys from pages 375 to 527 until August 15, 1981.

Four Games in one

The Game Machine™ lets you break the bank at Vegas playing Black Jack, go to a carnival with Shooting Gallery, test your logic as a Code Hunter or narrowly escape crack-ups in the Grand Prix

\$47.97

without batteries

Each game is one quarter of the fun, but you'll never run out of quarters while playing computer games in your own arcade! Forget about a coin slot . . . just a touch of a button and you're ready to play on a deluxe, tabletop console with large fluorescent display and realistic electronic sound effects. There's a different scoreboard and control panel for each game . . . colorful overlays pop in and out to change the look of the Game Machine™ and add to the excitement. Snap on the overlays, select a game and you're ready to play.

FOUR DIFFERENT CHALLENGES IN ONE

Black Jack tests your daring and decision-making as you decide to "hit" or "stand" against an electronic dealer. It takes quick reflexes and an accurate "trigger finger" to hit Shooting Gallery's target as it dodges across the board on a zigzag, random or cyclic pattern. Code Hunter tests your powers of deduction as you try to crack a secret 4-digit code, while it takes precision coordination to win the Grand Prix.



FOUR FUNCTIONS PLUS MEMORY IN ONE

When play time's over, just take off the overlays to reveal a four-function, seven-digit calculator with floating decimal and memory storage for performing chain operations. Use it to add, subtract, multiply or divide.



Large buttons and display make it simple and fun for everyone.

Solid state construction, microprocessor operated. Plastic case and plastic coated overlays. Case measures 11x6 1/4x5 1/2 inches. Score pads for all games are included. Take it along in the car or leave it on a desk . . . unit operates on 6 "C" batteries (not included).

AGES: For ages 6 yrs. to adult, 1 or more players. ORDERING INFORMATION: Order alkaline batteries below. Alkaline batteries can give up to 30 hours of use in the Game Machine™ compared to 6 to 8 hours of use with non-alkaline batteries. Shipping weight 2 pounds 8 ounces.

49 C 65871 \$47.97

Package of 2 "C" cell DieHard alkaline batteries (not shown) for use with Game Machine. Shipping weight 5 ounces.

49 C 46839 Package \$1.39



Extra Cartridges
\$15.97
each



Microvision™ Hand-held Electronic Cartridge Game

Now you can play TV-type games anywhere, change games in a flash with optional cartridges. Each cartridge includes a miniature screen and easy-to-use controls. Game System incl. "Block-buster" cartridge . . . object of game is to knock down a wall block by block. Additional cartridges sold at right. Cannot be used with TV. CONSTR: Plastic control console is 9 1/2x3 1/2x1 1/2 in. high. FOR AGES: 8 years to adult. ORD INFO: Uses two 9-v. batteries; not incl., order on p. 664. Warr. by Milton Bradley. Write for free copy, see p. 322.

LAST DATE TO ORDER
THIS ITEM IS
JANUARY 31, 1980
Shpg. wt. 1 lb. 11 oz.
49 C 65395 . . . \$39.97

Microvision Cartridges. Use with System sold at left.

- (1) Connect Four®. Build row of 4 objects before opponent. 49 C 65396—Wt. 11 oz. . . \$15.97
- (2) Star Trek™ Phaser Strike. Shoot down moving targets. 49 C 65399—Wt. 11 oz. . . \$15.97
- (3) Pinball. Do not order before November 1, 1979. 49 C 65404—Wt. 11 oz. . . \$15.97
- (4) Bowling. Do not order before December 1, 1979. 49 C 65398—Wt. 11 oz. . . \$15.97

Game System
\$39.97
without batteries

CHRISTMAS is for Children
FAMILY GAME CENTER

ATARI® POWER/PRICE BREAKTHROUGH!



Back deck offers enough ports and outlets to plug into all the fun

The new ATARI 800XL™ with 64K memory offers more power at a lower price than any other computer we've ever sold

\$249.99

More power . . . thanks to 1/2 more memory than the Atari 800. It's got a 64K memory that will expand up to 256K with the new ATARI Expansion System (to be introduced by ATARI and will be available at Sears in the near future).

Stretch your range of creative options

Use the built-in ATARI BASIC Programming Language to fully utilize the exclusive ATARI Computer sound and graphics or, try advanced programming languages. Start using your computer immediately with the program cartridges sold below . . . they just slip into a slot on the console.

Full-size, full-stroke typewriter-like keyboard

It has a HELP key for additional info and menu screens. A Self-Test program updates you on computer's performance each time you turn it on. International character set lets you type in foreign languages. 11 elaborate graphics modes, 256 dazzling colors and 4 independent sound channels with a 3 1/2 octave range.

Built-in expansion connection

External processor bus (connector) will allow the connection of future ATARI peripherals and accessories. TV output, monitor output, 2 controller ports and serial I/O connector. Includes TV switch box, AC power adapter (UL listed), Owner's Guide and ATARI BASIC Programming Language Reference Card. See 1983 Fall General for larger selection of programs, pg. 866-87. Warranted by ATARI, Inc. Write for free copy, see page 323.

3 E 7601C—Shipping weight 8 lbs. \$249.99

ATARI'S famous graphics add fun to more than just your games

Joust™ Take an adventurous ride on the back of an ostrich, knock other players off their buzzards.
3 E 76378—Shipping weight 5 oz. . . \$39.99

Football™ The thrills of football without the bruises. Realistic gameplay for offense, defense, call audibles.
3 E 76377—Shipping weight 5 ounces. . \$39.99

Pengo™ Propel your penguin thru ice block field as he smashes deadly sno-bees before they crush him. ©Sega Enterprises, Inc.
3 E 76380—Shipping weight 5 oz. . . \$39.99



Pole Position™ Ultra realistic graphics and sounds of the Gran Prix explode into your living room. Qualify on lap-time then take on the Fuji raceway.
©Namco Ltd.
Shpg. wt. 5 ozs.
3 E 76381 . . \$39.99

Boulders & Bombs™ 99 levels of terrific tunneling adventures under surface of unknown planet. Hostile alien vultures seek to turn you into buried fossils.
3 E 23281—Shipping weight 4 oz. . . \$34.99

K-Razy Shootout™ While trapped within deadly Alien Control Sectors, your squad of Space Commanders shoot it out with dangerous alien droids.
3 E 23282—Shipping weight 4 oz. . . \$29.99

K-Razy Kritters™ Clear screen of eight columns of Alien Kritters before they crash down on you or your star base. Ten levels.
3 E 23283—Shipping weight 4 oz. . . \$34.99



Mountain King™ Journey thru diamond-laden mountain caverns in search of the elusive Flame Spirit . . . the mystical key that unlocks the door to glorious and ancient Throne Room and treasure within.
Shpg. wt. 4 oz.
3 E 23280 . . \$34.99



Zaxxon™ Maneuver your high powered super jet past the ground/air missiles while trying to destroy their fuel dumps and missile sites.
Wt. 4 oz.
3E76307 . . \$39.99

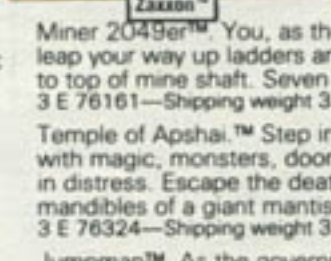

Miner 2049er™ You, as the miner, must leap your way up ladders and other obstacles to top of mine shaft. Seven skill levels.
3 E 76161—Shipping weight 3 oz. . . \$49.99

Temple of Apshei™ Step into a labyrinth filled with magic, monsters, doomed damsels in distress. Escape the death-grip mandibles of a giant mantis.
3 E 76324—Shipping weight 3 oz. . . \$39.99

Jumpman™ As the government's top-secret weapon, you must defuse bombs and restore communications. Fight off robots, dragons, birdmen and flying saucers. Keep cool.
3 E 76323—Shipping weight 3 oz. . . \$39.99



Demon Attack™ Pulsating, screaming creatures attack in waves. Fend them off with laser cannons. They keep on coming.
Wt. 4 oz.
3E23250 . \$29.99

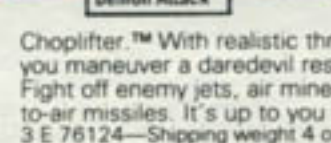

Choplifter™ With realistic throttle action, you maneuver a daredevil rescue chopper. Fight off enemy jets, air mines, tank fire, ground-to-air missiles. It's up to you to rescue hostages.
3 E 76124—Shipping weight 4 oz. . . \$44.99

Frogger™ You must safely guide froggie home across the river avoiding slithering snakes, awful otters, crustaceous crocodiles. ©Sega.
3 E 23340—Shipping weight 2 oz. . . \$49.99

All programs trademarked by individual manufacturer. Each offers a warranty. Write for free copy, see p. 323.



Donkey Kong Jr.™ When Mario the carpenter captures Donkey Kong, little Junior pursues him thru the dense jungle in an effort to save his papa.
©Nintendo.
Shpg. wt. 5 oz.
3 E 76376 . . \$39.99

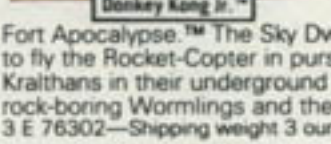

Fort Apocalypse™ The Sky Dwellers have chosen you to fly the Rocket-Copter in pursuit of the evil Kraithans in their underground Fort. Watch out for rock-boring Wormlings and the Vaults of Draconis.
3 E 76302—Shipping weight 3 ounces. . \$34.99



Ms. Pac-Man™ America's first lady of the arcade. Ever-hungry, she glides thru multiple mazes, gobbling up energy dots, ghosts and fruits.
©Bally Midway Mfg. Co., licensed by Namco-America, Inc. Wt. 5 oz.
3 E 76379 . . \$39.99

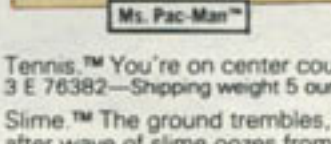

Tennis™ You're on center court at Wimbledon. Good luck!
3 E 76382—Shipping weight 5 ounces. . \$39.99



Slime™ The ground trembles, nature rebels, as wave after wave of slime oozes from the heavens. Oh no!
3 E 76383—Shipping weight 5 ounces. . \$44.99

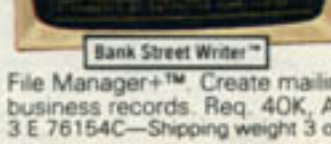

Bank Street Writer™ Home-oriented word processing system. No complex commands to memorize. On-screen operating instructions. Requires 48K and ATARI Disk Drive.
Shpg. wt. 5 oz.
3 E 76342 . . \$69.99

File Manager+™ Create mailing lists, inventory/business records. Req. 40K, ATARI Disk Drive.
3 E 76154C—Shipping weight 3 ounces. . \$99.99

Peter Pan's Daring Escape™ 2 learning adventures. Outsmart and elude the villainous Captain Hook. Ages 11 and up. ©MCMXXXIII by Walt Disney Productions.
3 E 76385—Shipping weight 5 oz. . . \$44.99



CUT \$10 (I, J)



CUT \$15

Men's digitals

Great no-wind watches at great low prices. MOVEMENT: Solid state quartz crystal that vibrates 32,768 times per second. Powered by a tiny long-lived jeweler's battery (included), it provides an LCD read-out (liquid crystal display) that's accurate to within seconds per month... as precise as far more costly quartz timekeepers.

ORDERING INFORMATION: Gift-boxed for giving. Carry Manufacturer's Warranty,† except for (L) with a Wards Warranty††

New watersport

A Casio® chrono-alarm sport style. CONSTRUCTION: Black high-impact plastic case, adjustable matching bracelet. FEATURES: This quartz watch goes underwater—safe to 100 meters, can be worn in the pool or on the boat. Since not specifically designed for scuba diving, if exposed to sea water, should be washed off in fresh water and dried. As a timekeeper—shows hours, minutes, seconds, AM/PM indicator, month, date and day in regular and military time. As a stopwatch times to 1/100th second up to 59 minutes, 59.9 seconds, normal time, net time, laps, 1st-2nd place times. As an alarm—even sounds underwater! Count-down alarm signals at 10 minute intervals; 24-hr. alarm signals every 30 minutes with a bip on the half-hour, a beep on the hour. Made in Japan. 45 T 865 LS—Ship. wt. 10 oz. 39.95

CUT \$1-\$4

B 6-digit budget timekeeper. CUT \$1 from '80 Christmas pg. 116. CONSTRUCTION: Silvertone base metal bezel, dark blue mask, stainless steel back, adjustable bracelet. FEATURES: Displays constant hour-minute-second (or date-day flag). At push-button command—month-date-year as well as night light and PM indicator. 45 T 810 L—Wt. 12 oz. . . was 19.95; 18.95

C Texas Instrument® budget 4-digit. CUT \$4 from '81 Fall Book pg. 129. CONSTRUCTION: Sporty black plastic case and bracelet shrug off sweat. FEATURES: Displays constant hour-minute; at push of button—month-date-secs. 45 T 818 L—Wt. 10 oz. . . was 14.95; 10.95

CUT \$10-\$15

D Novus® chrono-alarm dual-timer. CUT \$10 from '81 Spring page 103. CONSTRUCTION: Black plastic sports design with racy strap from Hong Kong. FEATURES: 6-digit: constant hour-minute-day flag-date (or seconds). At push-button command, slips into chrono mode to time laps, events, elapsed time to 1/10 second... or functions as an AM/PM alarm... or gives time in second time zone. 45 T 824 LS—Wt. 12 oz. . was 29.95; 19.95

E 6-digit chrono-alarm in color choice. CUT \$15 from '80 Christmas page 115. CONSTRUCTION: Base metal bezel, stainless steel back, adjustable bracelet. FEATURES: Gives you hour-minute-second day flag constantly. Push buttons summon month and date, night light, chronograph and alarm functions too. In chrono mode... times to 1/10 second—laps, events, elapsed time. In the 24-hour mode, rings AM/PM and signals on the hour. Wt. 12 oz. 45T806LS—Silvertone . was 39.95; 24.95 45T813LS—Goldstone . was 49.95; 34.95

CUT \$2

F 6-digit chronograph from Hong Kong. CUT \$2 from '80 Christmas page 118. CONSTR.: Lightweight black plastic. FEATURES: Shows hour-minute-second-month-date, day. As chrono, times to 1/10 second—laps, elapsed times, events. 45 T 803L—Wt. 10 oz. . . was 14.95; 12.95

Prime timers

G Novus® 4-digit LCD digital watch. CONSTR.: Chrome-plated bezel, blue mask, stainless steel back, adj. bracelet. FEATURES: Constant hour-minute read-out; month-date, seconds, night light on command. 45 T 751 L—Hong Kong. Wt. 12 oz. . 14.95

H Novus® 6-digit alarm design. CONSTR.: Weatherproof black plastic. FEATURES: Constant hour-minute-date-day of week in large digits. Seconds, quarter minutes in graphic presentation. 24-hr. easy-set snooze alarm. Backlight. 45 T 857 L—Ship. wt. 10 oz. 14.95

CUT \$10 (I, J)

I Handsome 6-digit LCD alarm. CUT \$10 from our '81 Fall Book, pg. 129. CONSTRUCTION: Tailored stainless steel design with matching adjustable bracelet. FEATURES: Displays constant hour-minute-second-day flag; at push-button command—month-date-year, night light, AM/PM alarm. From Hong Kong. Ship. wt. 12 oz. 45 T 822 LS—Silvertone was 29.95; 19.95 45 T 823 LS—Goldstone was 39.95; 29.95

Whiz watches

J 8-digit wrist calculator. CUT \$10 from our '81 Fall Book, pg. 129. CONSTRUCTION: Black plastic water-resistant* design. FEATURES: A whiz at math—adds, subtracts, multiplies, divides. 6-digit read-out gives hour-minute-second. Backlight for night viewing. From Japan/Hong Kong. 45 T 814 LS—Wt. 12 oz. . was 39.95; 29.88

K Dual design—digital and analog time combined in one watch. CONSTRUCTION: Slick brown plastic design that ignores sweat, looks terrific on your wrist. FEATURES: Tells time 2 ways: with a 6-digit LCD display and a regular dial with hands. Lets you keep time in 2 different time zones or in one time zone 2 ways. A chronograph also—times to 1/10 second in laps or elapsed time—and a 24-hour alarm... all things to one man. 45 T 942 LS—Ship. wt. 12 oz. 44.95

CUT \$15

L LeGant® blade-thin chrono alarm. CUT \$15 from '81 Fall Catalog, pg. 129. CONSTRUCTION: Base metal bezel, stainless steel back and adjustable bracelet. FEATURES: Only 4mm thick yet 6-digit display shows hour-minute-second-day flag in regular/military time. A calendar—gives month-date. A 24-hour repeat alarm—needs no resetting. A chrono—times to 1/10 second—laps, events, split events. Night light for convenience. Wt. 12 oz. 45 T 962 LS—Silvertone was 49.95; 34.88 45 T 963 LS—Goldstone was 59.95; 44.88

†Write for free copy of Manufacturer's Warranty, see pg. 322 for full details.

††FULL ONE YEAR WARRANTY ON MOVEMENT. Montgomery Ward warrants the movement of this watch against defects and will repair any defect free of charge for parts or labor for one year after date of purchase. For warranty service return watch with required evidence of date of purchase to any Montgomery Ward branch. For location of nearest branch consult phone directory or write National Customer Relations Manager, Montgomery Ward & Co., One Montgomery Ward Plaza, Chicago IL 60671. This warranty gives you specific legal rights and you may also have other rights which vary from state to state.

*Designed to withstand water pressure of 50 lbs. per sq. in. This quality can be maintained as long as crystal, crown and back remain intact.

Watches shown 1/2 actual size.

ELECTRONIC BRAIN GAMES



1

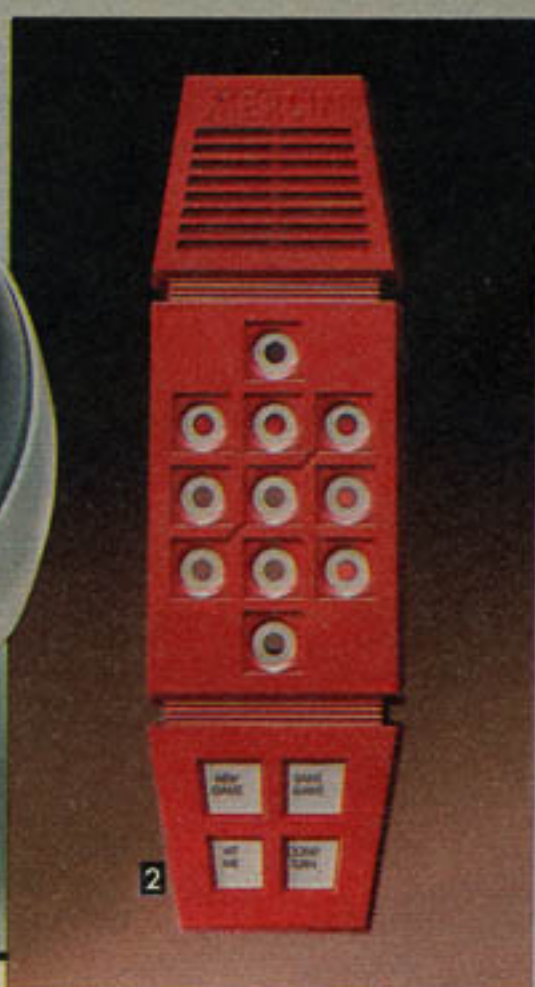

2



3



4



(1) **Computer Perfection™**
Test your memory with this challenging game inspired by space technology. Roll back dome, it's "on". The computer flashes light and sound "clues" to help you try to light its shapes in correct sequence. Includes four games at three skill levels; two games for solo playing and two for competitive playing.
CONSTR: Plastic, 8 $\frac{3}{16}$ x8x8 $\frac{7}{8}$ in. high.
FOR AGES: 8 years to adult.
ORDER INFO: Warranted by Lakeside Games. To write for free copy, see page 322. Requires two 9-v. batteries (not incl.; order below).
LAST DATE TO ORDER: JAN. 31, 1980
49 C 65863—Wt. 1 lb. 14 oz. \$29.97

(2) **Merlin the electronic wizard**
Merlin's 6 games include Tic-Tac-Toe, Music Machine, Echo, Blackjack 13, Magic Square and Mindbender. Merlin's memory instantly counters your moves with its own strategic maneuvers. Up to 9 levels of play, from beginner to expert. One or more players.
CONSTRUCTION: Plastic. Sensitive touch keys. 10x4x2 $\frac{3}{4}$ inches high.
FOR AGES: 7 years and up.
ORDERING INFO: Warranted by Parker Brothers; write for your free copy, see page 322. Requires 6 "AA" batteries (not incl., sold below) or adapter sold on page 669.
LAST DATE TO ORDER: JAN. 31, 1980
49 C 61061—Shpg. wt. 13 oz. \$24.97

(3) **STOP THIEF® Electronic Board Game**
The first board game with an exciting electronic dimension. Board represents a city block in which a crime is committed. Players use sound effects and visual clues to track and arrest thief, collect bounty and win. 2 to 4 players.
CONSTRUCTION: Plastic Crime Scanner computer, 8 $\frac{3}{8}$ x2 $\frac{7}{8}$ x1 $\frac{1}{2}$ inches high. Game board measures square 19 $\frac{3}{4}$ in.
FOR AGES: 8 years to adult.
ORDER INFO: Warranted by Parker Brothers; write for free copy, see pg. 322. Requires 9-v. battery (not incl.; order below) or adapter sold on pg. 669.
49 C 65729—Wt. 2 lbs. 3 oz. \$22.87

(4) **QUIZ WIZ™ Computer Answer Game**
Choose one of 1001 questions from the quiz book, pick an answer from the multiple choices provided. Enter question and answer in the Computer; lights and sounds tell you if your answer is correct or incorrect. Play alone or compete with others.
CONSTRUCTION: Plastic, 9 $\frac{1}{2}$ x5 $\frac{1}{2}$ x1 $\frac{1}{2}$ inches high. Vinyl case.
FOR AGES: 7 years to adult.
ORDER INFO: Uses 9-volt battery (not incl., sold below) or adapter sold on pg. 669. Order extra Quiz Wiz™ cartridge/books below.
49 C 62273—Shpg. wt. 8 oz. \$19.97

(5 thru 10) **QUIZ WIZ™ Cartridge/Quiz Books**
Use with your Quiz Wiz™ Computer. Each includes programmed cartridge and quiz book with 1001 questions, multiple choice answers.
ORDERING INFORMATION:
(5) **Movies and TV**
49 C 65669—Shpg. wt. 4 oz. . . . Each \$4.77
(6) **Trivia**
49 C 65671—Shpg. wt. 4 oz. . . . Each 4.77
(7) **Music and Books**
49 C 65672—Shpg. wt. 4 oz. . . . Each 4.77
(8) **Book of Lists**
49 C 65673—Shpg. wt. 4 oz. . . . Each 4.77
(9) **Greatest Sports Legends**
49 C 65674—Shpg. wt. 4 oz. . . . Each 4.77
(10) **Super Heroes***
49 C 65675—Shpg. wt. 4 oz. . . . Each 4.77

*™ and © D.C. Comics, Inc. and Marvel Comic Group
DieHard Alkaline 9-volt Battery.
49 C 46859—Shpg. wt. 2 oz. . . . Each \$1.49
DieHard Alkaline "AA" Batteries. Pkg. of 2.
49 C 46819—Shpg. wt. 2 oz. . . . Pkg. \$1.19

999.99 No money down
\$50 a month*
Save \$150. GE portable VCR

D Dockable combination portable/home VHS VCR gives you the best of both worlds! Recorder section disengages from tuner/timer for use outdoors (with optional camera), slides back in for use at home. Great fun for the whole family!

4 heads allow for great functions such as Variable Slow Motion, Video Scan (forward and reverse) high-speed scanning and Freeze Frame/Frame Advance for frame-by-frame viewing.

17-function wireless remote control performs Slow Motion, Scan, Freeze Frame/Frame Advance, Record, Play, Rewind/Stop/Fast-Forward, Channel Up and Down, Mode (VCR/TV) and Power On/Off.

8-event/14-day automatic timer allows you to record as many as 8 different programs on any channel (or different channels) up to 14 days in advance. Timer has 8 separate electronic timers. 8-hour capability (depending on tape speed).

Stereo/Dolby noise reduction sound system lets you dub a stereo soundtrack using your Hi-Fi system. Soft-touch electronic tuning lets you change channels randomly/directly or by scanning through them.

Lighted digital channel readout. Direct camera jack. UL listed. Made in Japan. Manufacturer's Warranty.** Was 1,149.99 in our '84 Fall Big Book, page 683.

63 G 79064 MS—Ship. wt. 17 lbs. now 999.99

899.99 No money down
\$45 a month*
Save \$100. GE video camera

E GE deluxe color video camera lets you film your own "movies" indoors or outdoors. Has adjustable electronic Viewfinder—a built-in 1-inch black/white monitor that allows you to see what you're filming. Automatic Dater/Title incorporates an electronic clock and calendar to date tape or to subtitle tape by simply pressing buttons under the concealed door. Also has stop watch feature!

Auto Focus employs an infrared beam to focus lens automatically. 8:1 Zoom Lens for close-ups and wide angles with the touch of a button. 1/2-in. Newvicon tube for excellent low light capability. Auto/manual Iris-control adjusts. Fade in/out control. Focus in/out control. Stereo microphone. Manufacturer's Warranty.** Was 999.99 in our '84 Fall Big Book, page 683.

63 G 79164 MS—Ship. wt. 8 lbs. now 899.99



Automatic Dater and Titler allow you to date and caption your film by simply pressing a button behind the concealed door

Includes 17-function wireless remote control with Slow Motion, Scan and Freeze Frame

Recorder section disengages for use outdoors!



Save \$100 **649.99** No money down
\$33 a month*
GE portable VHS video cassette recorder

F Easy-to-handle, simple-to-operate portable VCR from GE lets you become a videotape expert! Lightweight recorder is easy to use outdoors or at home. Enjoy up to 8 hours of recording/playback time. 1-event/24-hour automatic timer allows unattended recording for recording any program while you're asleep, away from home, or watching another program on another channel.

Audio dubbing capacity lets you add soundtracks to your tape. Soft-touch electronic tuning is fingertip-easy! Lighted digital electronic clock/timer. Lighted channel indicators. Direct camera jack.

Still Frame/Frame Advance lets you "freeze" the action, then get a detailed frame-by-frame look. Great for baseball replays and checking your golf swing.

5-power capability: internal battery pack, plug-in AC adapter, vehicle cord, quick-charge adapter (all not included), or use the tuner power supply (included). Made in Japan. UL listed. Manufacturer's Warranty.** Was 749.99 in our '84 Fall Big Book, page 682.

63 G 79054 MS—Ship. wt. 14 lbs. now 649.99



Save \$150 **499.99**
GE color video camera

G No money down. \$25 a month! GE lightweight, compact, portable color video camera brings good things to life! Power Zoom for tight close-ups and wide angles. 1/2-in. Newvicon tube provides greater light sensitivity. Viewfinder is also a monitor that lets you see what you're filming. Also allows in-camera playback using portable deck and earphone (earphone is not included). Manual focus. Macro focus for shooting tiny objects. Fade in/out control. Automatic white balance adjusts to color temperature levels for optimum color reproduction. Stand-by power switch. Built-in microphone. Manufacturer's Warranty.** Was 649.99 in our '84 Fall Big Book, page 682.

63 G 79154 MS—Ship. wt. 29 lbs. now 499.99

There's no limit to what youngsters can achieve when you make learning fun... the Computron™ does just that!

Cut \$10

Only **\$29.99**

DEVELOPS MATH SKILLS

EXPANDS POWERS OF LOGIC



Problems appear on the easy-to-read LED screen, as children use the colorful lesson book to follow along

This entertaining playmate also helps children learn the alphabet and improve their spelling. 10 games and an amazing 25,000-problem memory offer lots of exciting challenges for young minds. The touch-sensitive keyboard responds quickly to each entry and a correct answer wins a musical salute!

And, children can create their own songs on Computron's full musical scale, or play the tunes provided in the lesson book. Unit automatically shuts off when left unattended. Requires 6 "C" batteries, sold separately on p. 459. Was \$39.99 in our 1985 Toy Specialog, p. 496. For ages 5 to 12 years. 49-E-17702—Shpg. wt. 3 lbs... Now **\$29.99**

Sears, Roebuck and Co. 55 ES 7708

There's more for your life at
SEARS



TV not included



SAVE \$150
to **\$300**
on the Atari
Home Computer
System

**This Advanced Personal Computer is a Great Educational Gift—
Audio/Digital Cassettes Talk and Teach Through Your TV**

- 1 ATARI 800 PERSONAL COMPUTER.*** Provides the services of a teacher, a secretary, a financial advisor, or a companion right in your home. All the programming of this powerful computer is stored on cartridges which can be operated simply and easily. Connect the Atari 800 to a TV and it's ready for use. Data may be entered into the system by a variety of media including cassette tape (not included, see [2]), disk memory (not included—see [4]), pre-programmed cassettes (see [5]) or the system's keyboard. Once entered the data may be recalled and displayed on the TV screen or printed for hard copy (order printer [3]). Complete manual included. Unit includes basic language cartridge. Typewriter-style operating keyboard. 2 cartridge ports. Modular construction for easy memory expansion. Includes 16K Ram (random access memory) expandable to 48K memory. Measures 12 1/2 x 16 x 4 1/2 in.
X 641-0393 A—Delivery weight 24 lbs. 1080.00
- 2 CASSETTE RECORDER.*** Push-button controls for rewind, fast-forward, stop, record, play, and eject. 2 channels (1 Digital, 1 Audio). 3 digit tape counter.
X 641-0427 A—Del. wt. 4 lbs. 89.95
SAVE \$150 When You Buy Atari [1] and Printer [3].
X 641-2886 A—Wt. 38 lbs. Both for 1,529.95
SAVE \$150 When You Buy Atari [1] and Disk [4].
X 641-2951 A—Wt. 35.50 lbs. Both for 1,629.95

- 3 SAVE \$300** When You Buy All Three [1], [3] [4].
X 641-2969 A—Wt. 49.50 lbs. All 3 for 2,079.90
- 3 PRINTER FOR ATARI 800*** uses standard roll paper and ribbon. Dot matrix impact type print-out. Prints 40 characters per second, one line per second. Constructed with a power switch and indicator, paper advance button, and a built-in microprocessor.
X 641-0443 A—Del. wt. 14 lbs. \$599.95
- 4 FLOPPY DISK DRIVE FOR ATARI 800*** stores over 92K bytes of information on one disk. One disk incl. Up to four disks can operate with a system. Constructed with an automatic standby (built-in microprocessor); crystal controlled for accuracy.
X 641-0435 A—Del. wt. 11.50 lbs. 699.95
Blank Disks, Package of 5.
X 641-3884 A—Del. wt. 1.20 lbs. 25.00
- 5 PRE-PROGRAMMED SOFTWARE FOR ATARI 800.** In color, used with color TVs.
Educational Cassettes: Require Dorsett Cartridge (below). 01 spelling; 02 U.S. history; 03 U.S. government; 04 great classics of the western world; 05 basic psychology; 06 economics. *State subject number-and-name.*
X 641-2068 B—Del. wt. 0.50 lb. 24.95

- Dorsett Educational System Cartridge.** Required for use of educational cassettes (above).
X 641-2035 A—Del. wt. 0.50 lb. 24.95
- Game Cartridges:** 01 superbreakout; 02 basketball; 03 video easel; 04 chess. *State subject number-and-name when ordering.*
X 641-2076 B—Del. wt. 0.50 lb. 39.95
- Entertainment Cartridges:** 01 music; 03 star raiders. *State subject number-and-name.*
X 641-2084 B—Del. wt. 0.50 lb. 59.95
- Game Stick for use with game cartridges above.** Adds maneuverability to games.
X 641-2027 A—Del. wt. 0.50 lb. 19.95
- Paddle Control for Superbreakout Game Cartridge** (sold above). Del. wt. 1.70 lbs.
X 641-3330 A—2 paddles 19.95

*110-120V, AC, UL listed.
Warranted by manuf.—write for copy, see p. 363.



Perfect Gift for the Traveler

7 SAVE \$70
Only Till
December 27, 1980
On Craig M-100
Language Translator
NOW ONLY **99.95**
After Dec. 27, Order at Reg. Price

- 7 CRAIG M-100 LANGUAGE TRANSLATOR.** Uses self-contained, interchangeable memory capsules. Enter foreign words or phrases on the keyboard, and they appear in English. Translates from English. Accepts up to 3 language capsules at a time—order capsules below (English module is included). It's also a metric system converter and 8-digit calculator. Portable. Operates on 4 "AA" batteries (not incl.)—UL listed. Adapter/recharger incl. Warranted by manuf.—write for copy, see page 363. 6 1/2 x 3 3/4 x 1 1/4 in. Reduced from our big Fall '80 Catalog, see page 759. Delivery weight 1 lb.
X 641-0500 A Reg. \$169.95; NOW 99.95
- Language Capsules for Craig M-100 above.** *Languages:* 01 French; 02 Spanish; 03 German; 04 Italian; 05 Japanese. *State language number-and-name when ordering.*
X 641-0419 B Each 24.95

Come on,
Wizards
Pinball!



A
Deluxe
Plug-in
Electric Pinball
39⁹⁹



C Battery-Powered
Action Pinball
23⁸⁸



B
Super Score
Plug-in
Electric
Pinball
33⁸⁸



D Battery-Powered
Tabletop Pinball
15⁸⁸

Tic-Tac-Toe Nouveau



H
Triple Up
8⁴⁴



I
Toss Across
11⁶⁶



F Junk Yard
9⁷⁷

E
Roto Ball
1/4 Hockey
1/2 Pinball
17⁸⁷



Folds into carry case
418 JCPenney



G Flip Shot
Derby Pinball
8⁸⁹

**TOYS
AREN'T JUST
FOR CHRISTMAS**
Save this catalog. Order
anything from these two pages—
at these low prices—until August 12, 1978

ANSWERING MACHINE

DON'T MISS IMPORTANT CALLS—GET
THE MESSAGE MINDER WORKING FOR YOU!



Use the "beeper"
(included) to pick
up messages from
any location!



ORDER NOW!
OFFER ENDS
DECEMBER 12, 1987

SAVE \$30

SEARS REG. \$199.99

- Answers automatically—always at the ready, the Minder resets itself for the next call
- Installs in seconds—plugs into modular phone jack and any standard household outlet
- Voice activated; records messages up to two minutes long

169⁹⁹
Each

Never miss an important call with the Message Minder—your personal answering service! Convenient one-button playback rewinds tape, plays messages, then switches back to "ANSWER". Screen incoming calls—hear the caller *before* you answer. Has fast-forward and quick erase. LED flashes number of messages on tape. 9³/₄ x 7¹/₂ x 2¹/₂".
578 516 185 D—
Sears reg. 199.99 169.99



Messages just a phone call
away—punch in your access
code from any Touch Tone
phone in the world!

Video Arcade™ Cartridge System

Turns any TV set into a family game center



\$154⁹⁵

In our 1977 Wish Book, Sears introduced a new, programmable video game called Video Arcade. It was back then, and remains today, one of the most popular in the world. The reason is simple. With Video Arcade you can choose from such a large variety of game cartridges that your family should always enjoy playing with it.

IT WORKS LIKE A MINIATURE COMPUTER

The heart of this system is a micro-processor. By simply inserting a game cartridge, you automatically program the system to play a new series of exciting video games . . . all in vivid color on color TV sets, action sound, on-screen scoring.



There's even a special skill-option control with novice and expert settings for each player so the games can be made more challenging as your skills increase.

INCLUDES TARGET FUN GAME CARTRIDGE

This cartridge lets you choose from seven different playfields and 27 different games. It turns your TV set into a shooting gallery of fun as you try to hit the clowns, ducks and rabbits darting across the screen. Different objects have different point values and the winner is the first player to score 99 points. Other games included in this cartridge are Anti-aircraft, Torpedo, Missile,

Bomber and Missile vs. Bomber. And each of these can be made more challenging by selecting versions using steerable missiles, barricades or smaller missiles. You can even play against the built-in robot.

EVERYTHING'S INCLUDED BUT THE TV SET

The streamlined, impact resistant plastic console is 14 by 9½ by 3¼ inches high. It attaches easily to your TV antenna terminals with the special game switch that's included. You get four plug-in controls to play the various games: two joystick controls with firing button and two paddle controls (order extra set of paddle controls sold separately at right for those cartridges that have 3 or



4 player capability). Requires no batteries . . . operates on a 9-volt power supply with 16-foot cord. Just plug it in to any 110-v. AC outlet.
ORDERING INFORMATION FOR VIDEO ARCADE CONSOLE: Target Fun Cartridge included. See warranty on page 650.
6 C 99743—Shpg. wt. 6 lbs. 5 oz. . . . \$154.95

Target Fun Cartridge. (Not Shown.)

Described at left.
6 C 99802—Shpg. wt. 4 oz. \$19.95



KEYBOARD CONTROLS

12-key control unit to play Memory Match, Code Breaker and Brain Games.

ORDER INFO: Set of two. Wt. 11 oz.
6 C 99834 \$19.95

EXTRA PADDLE CONTROLS

Extra controls for 3 and 4-players games. Set of two. Wt. 10 oz.
6 C 99831 Set \$19.95

Extra Joystick Control. Wt. 4 oz.
6 C 99835 . . . Ea. \$9.95



Extra Game Switch

(Not shown.) Solves problem of unhooking and reconnecting TV antenna wires when moving game to a second TV.
6 C 99898—Wt. 6 oz. \$9.95

See next 2 pages for our wide selection of Video Arcade Cartridges



Save \$100
when you buy this
C64 computer bundle



B



C



D



E

You can also save
\$25 to \$102 when you buy
other computer and
peripheral combinations on
pages 1098-1100 in our
1985 Fall Big Book

A thru D. \$24 monthly* buys a gift for the whole family. The Commodore 64 system is easy to use; ideal for games and educational programs, yet versatile enough for business, too. (A) has 64K RAM memory, holds up to 27 double-spaced typed pgs. Learn to program with built-in Microsoft® PET BASIC language. 16-color selection reproduces games with close to arcade quality, or design your own games. 66-character keyboard, music synthesizer, and 40-column x 25-line display when hooked up to TV or monitor. C1702 composite video color monitor (B) has 13-in. diag. measure screen, 40-column x 25-line display, built-in speaker and audio amplifier. C1541 single disk drive (C) serves as a separate memory bank to save and retrieve your work (up to 170K of data, or 110 double-spaced typed pages on a 5¼-in. floppy disk, not incl.). Loads an average program in 20 seconds. Print what you've programmed at 60 characters per second with the MPS 803 impact dot matrix printer (D). Friction paper feed; also accepts tractor feed mechanism. All imported, warr. by Commodore™. Sep. prices for (A thru D) total \$749.96. 3 E 32201C—Shipping weight 68 pounds... System **\$649.96**

A. C64 computer alone. \$10 monthly*.
3 E 23220—Wt. 10 lbs. 4 oz. ... **\$149.99**

B. C1702 Monitor alone. \$11 monthly*.
3 E 23252C—Wt. 38 lbs. ... **\$219.99**

C. C1541 Disk Drive alone. \$20 less than 1985 Fall Big Book price of \$249.99, p. 1099. \$11 monthly*.
3 E 23221—Wt. 11 lbs. ... **\$229.99**

D. MPS-803 Commodore printer alone.
\$10 monthly*.
3 E 32440—Wt. 9 lbs. 8 oz. ... **\$149.99**

E. Joystick for C64, C128 and all Atari computers. Dual fire buttons for right or left-hand operation. Warranted by manufacturer*.
T 3 E 20881—Wt. 1 lb. ... **\$19.99**

Joystick like (E), but single fire button.
T 3 E 20880—Wt. 12 oz. ... **\$7.99**

White bond blank computer printout paper (not shown) for printer (D) above, or any other 80-column dot-matrix printer with track feeding. White; 9½x11 in. 1000 sheets per package.
T 3 E 76715—Wt. 13 lbs. ... Pkg. **\$14.99**

Printer interface (not shown) for Vic-20 and C64. Works with any standard parallel or serial printer. Cables, plug included.
T 3 E 76670—Wt. 13 oz. ... **\$69.99**

*See p. 338. **Write for free copy, see p. 335.

Looking for other computer software? Call toll-free at 1-800-THE-MENU. Orders may also be placed thru independently owned Catalog Sales Merchants or Agents, usually located in smaller towns

F. Disk storage case with automatic lift-off lid. Holds 35 5¼-in. mini diskettes (not incl.). Plastic.
T 3 E 76721—Wt. 1 lb. 4 oz. ... **\$9.99**

Case (not shown). Holds up to 70 5¼-in. mini diskettes. Smoked plastic; locking lid with key.
T 3 E 76720—Shpg. wt. 2 lbs. 11 oz. ... **\$19.99**

G. Cut \$2. Package of 11 double-sided/double-density mini disks. Was \$16.99 in our 1985 Fall Big Book, p. 1096.

T 3 E 20601—Wt. 14 oz. ... Pkg. **\$14.99**
Save \$5 when you buy (F and G). Sep. prices totaled \$26.98 in our 1985 Fall Big Book, p. 1096.
T 3 E 20602—Wt. 1 lb. 4 oz. ... Set **\$21.98**

H. Place the Incredible Musical Keyboard™ on top of your C64 or C128 keyboard and play piano, synthesizer, guitar or electronic sound effects with software (incl.). Incl. beginning and advanced music books. Was \$29.99 in our '85 Fall Big Bk., p. 1100.
3 E 76960—Shpg. wt. 3 lbs. ... **\$14.99**

*T prefix items could take extra delivery time

Save 10% when you buy any 2 or more software titles from our 1985 Fall Big Book, p. 1097 (does not incl. MENU orders). Simply use E key letter when ordering; for example, T 3 G 20009 becomes T 3 E 20009. State full price. Sears will make price adjustments. Sale effective 9/10/85 through 2/15/86.



F



G

Save \$5 when you buy (F) and (G)



H



Musical keyboard
1/2
PRICE

NEED A HEAVYWEIGHT BUSINESS COMPUTER? THE IBM-COMPATIBLE LASER COMPACT XT DELIVERS!

\$49999

\$17 MONTHLY,
NO PAYMENTS 'TIL JANUARY* 5



4 IBM-compatible Laser Compact XT has built-in 5¼-in. disk drive and 512K RAM, expandable to 640K. Color graphics adapter for RGB/composite color or monochrome monitors. Built-in turbo processor is 4.77/10 MHz, selectable from keyboard. Includes parallel printer interface, serial and joystick/game ports, speaker, Microsoft® MS DOS 3.3 and GW Basic. Imported. Warranted.**

3 E 32112C—Wt. 16 lbs. . . \$499.99

5¼-in. external disk drive (not shown) for (4). Double sided/double density. Cable incl. Imported.

3 E 32113—Wt. 5 lbs. . . \$169.99

Suncor TAC 1+® joystick (not shown) is compatible with Apple and IBM computers. Imported. Warranted.**

T 3 E 20886—Wt. 1 lb. 2 oz. . . \$24.99

5 High-resolution Magnavox monochrome monitor has 12-in. diagonal measure screen with anti-glare glass, green display. Composite video input. Interface cable incl. Warranted.**

3 E 32508C—Wt. 17 lbs. . . \$99.99

6 \$13 monthly, no payments 'til January*. Okidata® 180™ dot matrix printer is compatible with any computer we sell. Prints data, word processing at 180 characters per second, and near letter quality at 30 CPS. Has bottom-feed capability. Imported. Warranted.**

3 E 32417—Wt. 12 lbs. . . \$299.99

Black ribbon for Okidata 180 printer.

T 3 E 20921—Wt. 1 oz. . . \$6.99

Cable connects (1) or Laser 128 EX (not shown) to printer (6).

T 3 E 76653—Wt. 9 oz. . . \$16.99

Save \$30 to \$50 on computer combinations

Computer (1) and color monitor (2). Includes connecting cable. Sep. total \$699.98.

3 E 32103L—Wt. 47 lbs. . . \$649.98

Computer (1) and green monochrome monitor (5). Sep. total \$499.98.

3 E 32105L—Wt. 33 lbs. . . \$469.98

Computer (4) and green monochrome monitor (5). Sep. total \$599.98.

3 E 32107C—Wt. 33 lbs. . . \$569.98

Computer (4) and color monitor (2).

Sep. total \$799.98.

3 E 32108C—Wt. 47 lbs. . . \$749.98

*See page 305.

**Warranted by Sears or manufacturer. Write for free copy, see page 304.

NOTE: Catalog numbers with "T" prefix could take extra time for delivery.



The holiday way to say "Charge it!"
To apply for SearsCharge only
CALL TOLL-FREE
1-800-323-3274



A



D



E



F



G



C

B

Thrills, chills and excitement are just a pushbutton away...go for it!

A Pinball game—and watch! Colorful arcade graphics, realistic play-action, maneuvers and strategy, plus sound effects. Fits your pocket for on-the-go fun. Clock/alarm. Dual screen automatic scoring. Batteries included.

48 G 50052—Ages: 8 to adult. Ship. wt. 8 oz.29.88

B-C Super challenge, super color...as seen on TV. Pocket size case. 2 skill levels. Digital read-out with scorekeeper and clock/alarm. Long lasting batteries included.

(B) Crab Grab. Move up the colored rows and push all nasty crabs off the screen. It's tricky!

48 G 50053—Ages: 12 to adult. Ship. wt. 6 oz.29.99

(C) Spitball Sparky. Fast-paced game of strategic shooting and catching the bouncing ball.

48 G 50054—Ages: 12 to adult. Ship. wt. 6 oz.29.99

D-G Widescreen pocketsize arcade games with watch/alarm. Realistic arcade graphics, sound effects and digital scoring. Two long-lasting batteries included.

(D) Donkey Kong Jr™ swings through the jungle to save his father from Mario's prison.

48 G 50064—Ages: 8 to adult. Ship. wt. 4 oz.21.88

(E) Snoopy Tennis™. Snoopy must return Charlie Brown's serves. But Lucy keeps butting in and intercepting the ball from Snoopy.

48 G 50063—Ages: 8 to adult. Ship. wt. 4 oz.20.77

(F) Mickey Mouse®. Four chickens lay eggs. As the eggs roll down the four different drops, Mickey must catch them in his basket.

48 G 50065—Ages: 8 to adult. Ship. wt. 4 oz.20.77

(G) Popeye®. Popeye and Olive are loading the boat. Popeye has to catch the food Olive throws him as he dodges Brutus' attacks.

48 G 50062—Ages: 8 to adult. Ship. wt. 4 oz.20.77



Electronic
Pinball
22⁹⁴

Command Control™
Electric Football

14⁸⁸

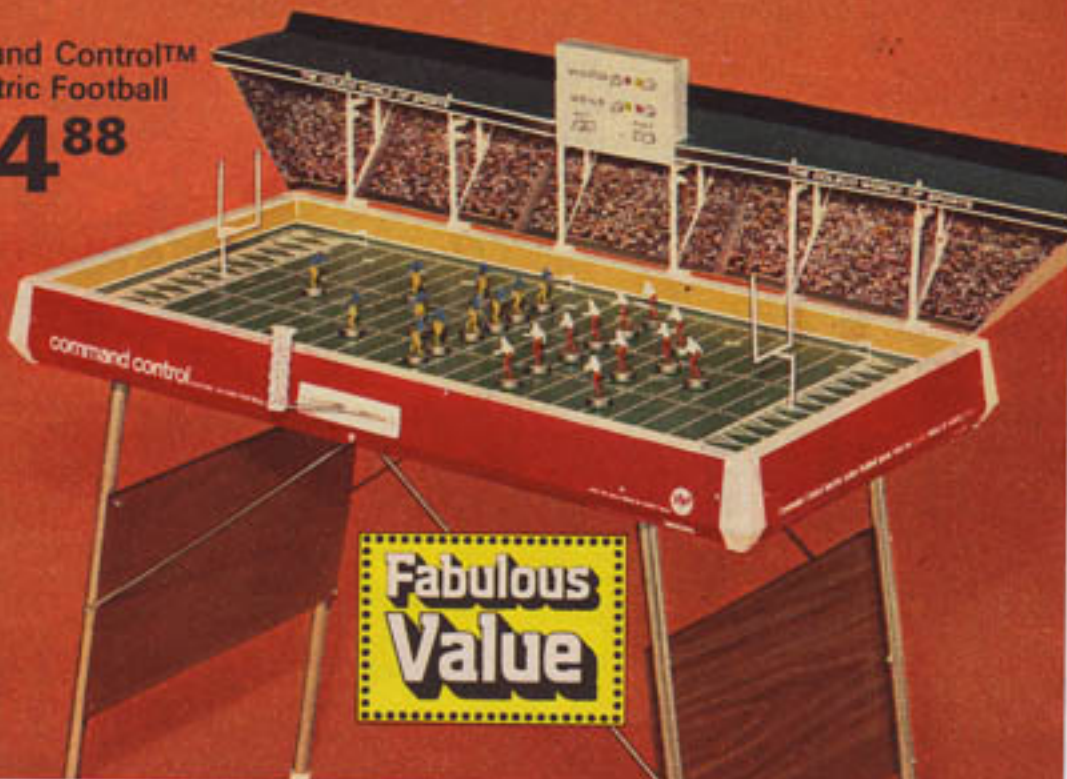

**Fabulous
Value**

Become the pinball wizard of your neighborhood! Battery operated pinball makes a perfect addition to your gameroom. Pull the lever and ball travels through obstacle course. Spinner activates . . . bells ring . . . score as high as 100,000! Sophisticated features of a professional game: submarine loading; 2 replay flippers. 29x14x43 in. H. Uses 4 "D" batteries, not incl., order pg. 369. For children 6 yrs. and older.

48 T 14667 M—Ship. wt. 19 lbs. 22.94

Extra point conversions! End sweeps! Quarterback sneaks! This game does it all. Direct-O-Matic™ lets you set the direction of each player separately. Develop your own game plan with the exclusive Strategy Play Formations. Also features: control action levers for each team; 2 action quarterbacks that really kick and pass; 3-dimension grandstand; magnetic footballs; vibrating field with variable speed control; scoreboard, goal posts, yard markers and flags; sturdy floor stand. UL listed. 38x21 in.

48 T 14577 M—Ship. wt. 16 lbs. 14.88



A
Electronic Table Tennis
32⁴⁹



B
Toss Across
12⁹⁹

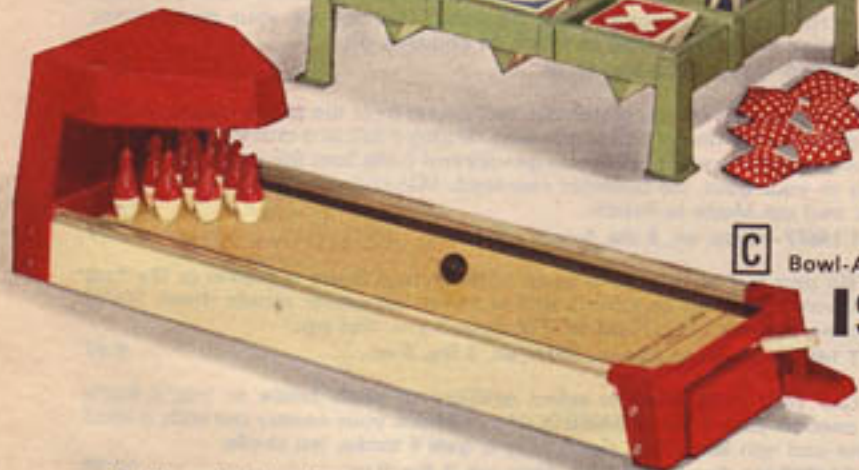

C
Bowl-A-Matic 300
19⁸⁴



D
Marble Shoot
6⁷⁷



E
Folding Soccer
12⁹⁹

A You'll need quick reflexes to beat your opponent in this game. "Ball" bounces back and forth on the screen. Ball must be hit the second it reaches your paddle . . . just push the button. Server also controls the speed of the ball. Uses 4 "D" batteries, not incl.—order pg. 369. 17x13x13 in.

48 T 14086 M—For children 7 yrs. and up. Ship. wt. 10 lbs. 32.49

B Beanbag version of Tic-Tac-Toe. Play indoors or out. Hit rotating symbols with beanbag to turn up "X" or "O." First player or team to line up 3 in a row, wins. Includes plastic frame on legs and 8 polka-dotted bean bags. About 22x18½ in. For children 6 yrs. and older, and adults.

48 T 14520 M—Ship. wt. 6 lbs. 10 oz. 12.99

C The great game you've seen on TV. Go for a strike on a real-life table-top bowling alley—right in your own living room! Remote control Bowl-A-Matic does it all—the amazing automatic pin-setter sets 'em up; automatic ball return lets you play hour after hour. Colorful molded pins are individually activated by fast moving ball. Solid wood-style construction, precision smooth alley. About 45x13 in. For fans 5 yrs. and up.

48 T 14883 M—Partially assembled. Ship. wt. 19 lbs. 19.84

D Have hours of fun competing with your friends, or "play" against yourself trying to beat your last score! Spring loaded plunger shoots marbles through the swirl-shaped launch chute, over and into the scoring holes. Marble then automatically returns so you can keep a record of your score . . . 0, 1, 3, 5, or 10. Comes with 10 marbles and detachable legs. For children 3 yrs. and up. 15½x9¾x2¼ in.

48 T 14670—Made in Japan. Ship. wt. 2 lbs. 11 oz. 6.77

E Official size team action! You control your team with telescoping rods to kick, fake and move from side to side while your opponent is doing the same. While you are trying to watch 22 men, the excitement continues to rise as you both plan your strategy to battle it out and score. Use on tabletop. Folds in half so you can carry it with you anywhere. Sturdy hardwood construction. About 30x16 in. Includes 2 balls. Not recommended for children under 3 yrs.

48 T 14682—Ship. wt. 7 lbs. 12.99



1. Get out-of-this-world fun with Space Turbo. This high-tech command center puts you behind a digital screen that displays realistic alien attacks. Push button joystick controls, laser blasts. Requires 4 "D" batteries, sold separately on page 459. For ages 4 years and up. 49 C 65312—Shpg. wt. 4 lbs. . . \$24.99

2. Make the right move with Inside Moves. You'll love this strategy game. It's as easy to learn as checkers, yet it offers the challenge and skill of chess. For 2 players. For ages 8 years and up. 49 C 61513—Shpg. wt. 1 lb. 9 oz. . . \$14.99

3. Make sure you have the Last Word™ Here's an innovative word game which lets players find and remove hidden words from playing surface without getting "trapped." For 2 to 4 players. For ages 10 years to adult. 49 C 61433—Shpg. wt. 2 lbs. 3 oz. . . \$11.99

4. Be like Rodney Dangerfield—get No Respect™ Amusing strategy board game with great social interaction. Players try to collect numbered tiles in descending order before opponent "freezes" action. For 2 to 4 players. 49 C 61430—Shpg. wt. 2 lbs. . . \$11.99

5. What you see isn't what you get in the Transformers™ adventure game. Action-filled game features all 26 Transformers™ characters. For ages 7 years to adult. 49 C 61911—Shpg. wt. 2 lbs. 2 oz. . . \$8.99

6. Put together some fun with My Little Pony™ 3-D Stand Up puzzles. These 2 jigsaw puzzles feature the favorite "Pony" as a collectible 3-D character. Puzzle pieces also form an adventure scene. For ages 5 to 10 years. 49 C 63042—Shpg. wt. 2 lbs 8 oz. . . \$9.99

7. Round-up some fun with the My Little Pony™ 3-D Stand Up game. Features a 3-dimensional playing board and all the popular "Pony" characters. Requires no reading. For ages 4 to 10 years. 49 C 61910—Shpg. wt. 2 lbs. 3 oz. . . \$6.99



8. You'll jump for "Rib-bit" Battle of the Frogs. It's an all-out battle of wits and fun, using frog pieces that move and capture each other. For 2 players. For ages 8 years to adult. 49 C 61049—Shpg. wt. 2 lbs. 8 oz. . . \$9.99

9. Let the good guys play the G.I. Joe Commando Attack game. Exciting adventure game pits the G.I. Joe team against evil Cobra army. For 2 to 4 players. For ages 6 to 12 years. 49 C 61417—Shpg. wt. 2 lbs. 7 oz. . . \$13.99

10. Have some "spook-tacular" fun with GHOSTS!™ The children's strategy board game of bluffing and capturing. Ghost pieces glow in the dark! For 2 players. For ages 6 to 12 years. 49 C 61415—Shpg. wt. 2 lbs. . . \$7.99

11. Take a spin on the Wheel of Fortune game. Just like on tv—solve the puzzle and win! For 2 to 4 players. For ages 8 years to adult. 49 C 61277—Shpg. wt. 1 lb. 8 oz. . . \$11.99

12. Get around with Rotation. Multi-level-action strategy game can be played at several skill levels. For 2 players. For ages 6 years and up. 49 C 62524—Shpg. wt. 1 lb. . . \$8.99

13. Enjoy spin and stamp fun with the My Little Pony™ Merry-Go-Round game. Players take turns spinning the top-like merry-go-round to match up colorful stamps. For 2 to 4 players. For ages 4 to 7 years. 49 C 62458—Shpg. wt. 3 lbs. 2 oz. . . \$11.99

14. Keep a lookout with the Cabbage Patch Kids™ Hide-and-Seek Game. Players search to find which kid is under what cabbage . . . but hurry before they slip into hiding. For 2 to 4 players. For ages 6 to 10 years. 49 C 62465—Shpg. wt. 2 lbs. . . \$14.99

15. The Cabbage Patch LCD game offers children 3 games to play. Try and maneuver the cabbage patch figure to jump around in the "fun lake." Unit works as an alarm clock, too. Batteries included. For ages 6 and up. Warranted.* 49 C 65403—Shpg. wt. 4 oz. . . \$12.99

16. Piece together playtime with the Transformers™ 3-D Stand Up puzzles. This set of 2 puzzles creates both an adventure scene and a 3-dimensional puzzle which transforms into an action figure. For ages 6 to 14 years. 49 C 63040—Shpg. wt. 2 lbs. 8 oz. . . \$9.99

17. Get real knock-out action with Transformers™ Fighting Robots. Players try and knock their opponent's "block off" by using control levers to maneuver robot's motions. Push button lever independently controls uppercuts. Durable 10½-inch high robots of high-impact plastic. For ages 3 years to adult. 49 C 62019—Shpg. wt. 7 lbs. . . \$12.99
*Warranted by manufacturer. Write for free copy, see p. 335.



A direct hit "explodes"!

1 Electric Aerial Aces
It's a WWI dogfight
See, hear the hits!

44⁹⁹



STAR TREK PHASER BATTLE

2 **54⁹⁹**

Electronic Phaser Battle
Attack the aliens! Defend
your spaceship under fire!



How's
your
aim?

3 Targetland
10⁹⁷



4 **9⁹⁸**

Magic Shot
The shots can't
stray (neither
can the gun)

**TOYS AREN'T JUST FOR
CHRISTMAS.**
Save this catalog. Order
anything on these two pages—at these
low prices—until August 12, 1978.



5 Hit the targets
with Chutes Away **14⁶⁹**



6 3-gun
target set **3⁹⁹**

Rattlin' Gattlin'
machine gun
action in an
enclosed gallery

7



15⁸⁹



8 Tin Can Alley
knocks down cans
with a harmless
beam of light!

27⁸⁸



9 Shoot 'N' Score . . .
The name says it all **39⁹⁹**

JCPenney 413

THE WRITE CHOICE

From basic typing to word processing,
typewriters to suit your needs...and budget



Electronic word processing
typewriter

Save \$100
\$299⁹⁹

**\$13 MONTHLY
NO PAYMENTS 'TIL JANUARY'**

- 40-character LCD display helps catch errors
- Includes word wrap, justification, search and replace functions
- 12,000-character editable text memory stores form letters for later recall
- 60,000-word dictionary checks your spelling



The Electronic Scholar

Cut \$100
\$199⁹⁹

**\$10 MONTHLY
NO PAYMENTS 'TIL JAN.'**

- 5000-character editable text memory
- 50,000-word built-in dictionary
- Dictionary lets you add up to 50 words of your own

2



SR 1000
Electronic Typewriter

Cut \$50
\$129⁹⁹

**\$10 MONTHLY
NO PAYMENTS 'TIL JAN.'**

- Full-line correction memory
- Automatic carriage return

3

| LCD readout lets you check grammar and spelling as you go along, and make corrections before the last 40 characters are committed to paper. Black carbon ribbon produces crisp, professional-looking copy. Accepts 10, 12 or 15 pitch typesets. 1, 1½, or 2 line spacing is electronically variable. Provides 12 tab positions, including decimal tabs. Allows repeat spacing, express back spacing, paragraph indent and auto underscoring. Accepts paper up to 12 inches wide, prints up to 9 inches wide. 17½Wx14Dx5H inches. Imported. Warranted**. Was \$399.99 in our 1988 Annual Catalog.

3 E 53508C—Wt. 19 lbs . . . **\$299.99**

Accessory kit for (1) includes 2 correction tapes, 2 carbon ribbons and 2 daisy wheels.

3 E 54067—Wt. 8 oz . . . Kit **\$34.99**

2 Accepts either 10 or 12 pitch type. 1, 1½ or 2 line spacing is electronically variable. Provides up to 16 tab positions, including decimal tabs. Allows repeat spacing, express backspacing, paragraph indent and auto underscore. Accepts paper up to 13 in. wide, prints up to 10 in. wide. 17½Wx14Dx4½H in. Imported. Warranted**. Was \$299.99 in our 1988 Annual Catalog.

3 E 53308C—Wt. 15 lbs . . . **\$199.99**

Cut \$5. Accessory kit for (2) includes 2 correction tapes, 2 carbon ribbons and 2 daisy wheels. Was \$24.99 in our 1988 Annual Catalog.

3 E 54076—Wt. 12 oz . . . Kit **\$19.99**

3 Accepts 10 or 12 pitch type and provides 1, 1½ or 2 line spacing. Accepts paper up to 12 inches wide, types up to 9 inches wide. 16Wx12¼Dx4¼H inches. Imported. Warranted**. Was \$179.99 in our 1988 Annual Catalog.

3 E 53002—Wt. 13 lbs. 8 oz . . . **\$129.99**

Accessory kit for (3) includes 4 carbon ribbons, 1 lift-off correction tape and 2 daisy wheels.

3 E 5477—Wt. 1 lb. 14 oz . . . Kit **\$49.99**

*See page 305.

**Warranted by Sears. Write for free copy, see page 304.



Enjoy learning!

1. *Speak & Read* uses a 250-plus word vocabulary, plus activities like "Word Zapper" and "Picture Read" to familiarize young children with letters and words. Activity book included. Warranted*. Requires 4 "C" batteries, sold separately on page 459. For ages 4 to 8 years. 49 C 17816—Shipping weight 2 pounds... **\$43.99**

A thru F. Additional learning modules for (1) incl. plug-in, module and activity booklet. Wt. 4 oz. ea.

A. "Who's Who at the Zoo" provides practice with contractions and endings; as "ING", "ED" and "ES". 49 C 17821—For grade level 2... **\$13.99**

B. "A Seal That Could Fly" teaches the use of comparative endings like "long, longER, longEST". 49 C 17817—For grade level 2... **\$13.99**

C. "Dog on a Log" familiarizes children with rhyming words like "hit-fit", plural words like "box-boxes" and possessive nouns like "mother's". 49 C 17822—For grade level 1... **\$13.99**

D. "On the Track" introduces children to a variety of initial consonant blends like "TRain" or "CRayon". 49 C 17823—For grade level 1... **\$13.99**

E. "The Third Circle" teaches about "r-controlled" vowels; as "IR" in circle, suffixes "FUL" and "LY". 49 C 17841—For grade level 2... **\$13.99**

F. "The Millionth Knight" features phonetics; as "KN" in knee and suffixes "TH", "MENT" and "OUS". 49 C 17842—For grade level 3... **\$13.99**

2. *Speak & Spell* has a 150-word vocabulary and 4 levels of difficulty to teach the spellings of words that don't follow normal rules. Incl. activity book. Requires 4 "C" batteries, sold separately on p. 459. Warranted*. For ages 6 years and up. Wt. 1 lb. 13 oz. 49 C 17807... **\$43.99**
49 C 17833—Braille *Speak & Spell*... **\$43.99**

G thru M. Additional learning modules for (2). Each includes plug-in module and lesson booklet. Wt. 4 oz. ea.

G. "Basic Builders" helps children master those often hard-to-spell words. 49 C 17837—For grade levels 2 to 4... **\$13.99**

H. "Vowel Power" helps make different vowel combinations a snap to pronounce and spell. 49 C 17838—For grade levels 2 to 4... **\$13.99**

J. "Super Stumpers" teaches about irregular spellings, silent letters, double consonants. 49 C 17839—For grade levels 4 to 6... **\$13.99**

K. "Mighty Verbs" teaches about past and present-tense verb spellings. 49 C 17843—For grade levels 4 to 6... **\$13.99**

L. "Super Stumpers II" zeroes in on commonly misspelled words and prepares children for more difficult writing assignments. 49 C 17844—For grade levels 6 to 8... **\$13.99**

M. "Vowel Venture" teaches about vowel combinations and spelling long vowel words. 49 C 17845—For grade levels 6 to 8... **\$13.99**

3. *Speak & Math* teaches number values and logic by using exciting games and over 100,000 word problems. Activity book included. Warranted*. Requires 4 "C" batteries, sold separately on p. 459. For ages 5 to 12 yrs. Wt. 1 lb. 6 oz. 49 C 17605... **\$43.99**

49 C 17606—Braille *Speak & Math*... **\$43.99**

AC power adapter for (1 thru 3) units (not shown). 49 C 17806—Shipping weight 1 lb. 5 oz... **\$9.99**

4. *Touch & Tell* teaches colors, shapes and common objects using game voice questions and answers and picture panels for children to identify. Includes 2 double-sided picture panels. Plastic. Warranted*. Requires 2 "D" batteries, sold separately on p. 459. For ages 2 to 5 years. 49 C 17801—Shipping weight 2 lbs. 3 oz... **\$33.99**

N thru T. Extra learning modules for (4) come with picture overlays.

Key	Description	Catalog No.
N.	"Animal Kingdom" helps children learn the names and sounds of animals	49 C 17853
P.	"All About Me" promotes self-awareness	49 C 17855
R.	"Alphabet Fun" helps identify letters and words beginning with those letters	49 C 17849
S.	"The World of Transportation" tells all about buses, planes, trains and more	49 C 17857
T.	"Number Fun" identifies numbers, values	49 C 17851
(Not Shown)	"Little Creatures" helps children learn about nature life	49 C 17859

Shipping weight each 14 oz... Each **\$13.99**

*Warranted by Texas Instruments.

Write for free copy, see p. 335.



• Difficulty levels from 8 years to adult

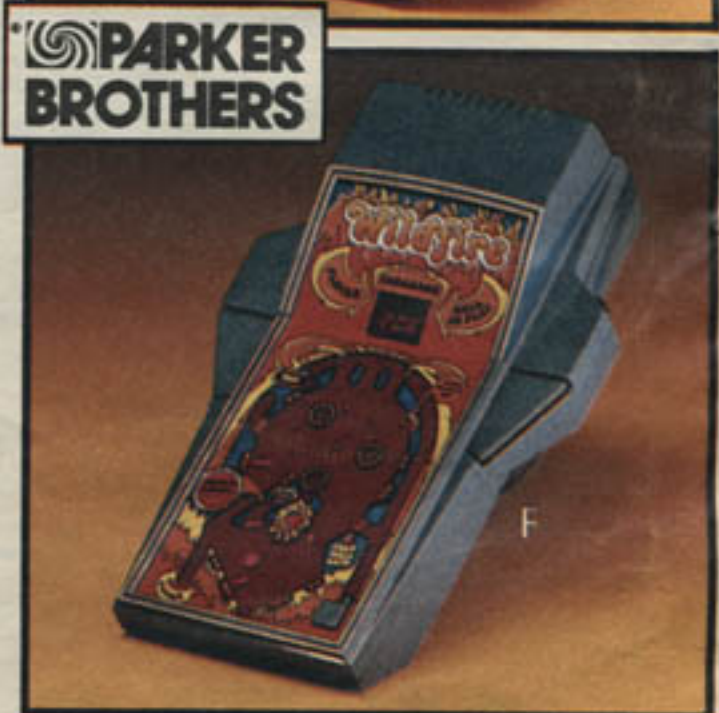
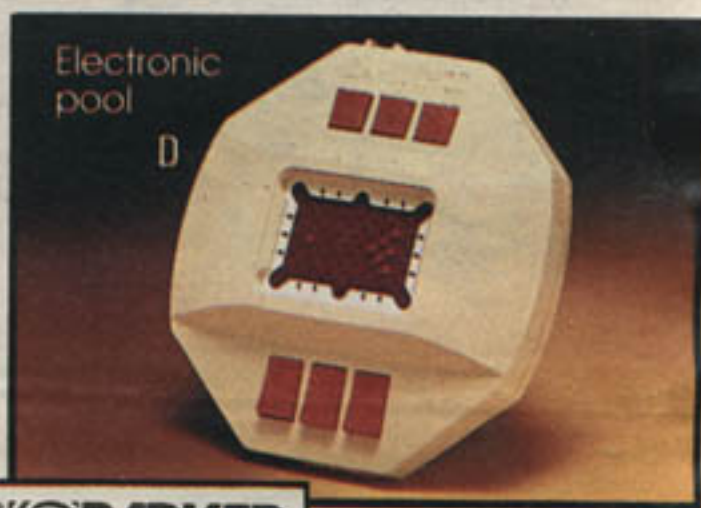

A Microvision™—the first complete hand-held non-video cartridge system.
FEATURES: Miniature screen with easily readable display and simple-to-use controls. Block Buster cartridge incl. Uses one 9-volt battery.*
 48 TF 14645—AGES: 8 and up. Wt. 1 lb. 6 oz. Until Dec. 1, 41.44
 48 T 14645 After Dec. 1, 44.99

CARTRIDGES FOR MICROVISION™. Wt. 8 oz. State code number. . . ea. 17.77
 L 48 T 14646—01-Baseball; 02-Bowling; 03-Vegas Slot; 04-Pinball
 L 48 T 14647—01-Star Trek; 03-Sea Duel; 05-Alien Raider; 06-Cosmic Hunter.

B Computer Backgammon . . . a relentless opponent you can take anywhere.
FEATURES: Liquid crystal display lets you see the game play indoors or outdoors. No loose pieces to get lost—it's all electronic. 6 challenging skill levels developed by a World Class player allow beginners or experts to play against the computer. Electronic doubling cube. Optional dice control allows you a choice between the computer's random dice roll or your own roll. Pen not included.
 48 T 14516—Uses one 9-volt battery.* AGES: 8 and up. Wt. 7 oz. . . . ea. 79.99

C Light Fight™ . . . be fast enough to survive devilish battle of dueling lights.
FEATURES: 5 games tease your memory, coordination. Play by pressing two correct keys that correspond to flashing light spots on the center grid.
 48 T 14507—Uses 4 "D" batteries.* AGES: 8 and up. Wt. 2 lbs. 4 oz. . . . 33.88

D Bank Shot™ electronic pool . . . takes skill, strategy to control angle, aim and speed of cue ball to make trick, cushion or combination shots and breaks!
FEATURES: 3 pool games, on-screen scoring, electronic sound effects.
 48 T 14547—Uses 6 "AA" batteries.* AGES: 8 and up. Ship. wt. 1 lb. 6 oz. . . . 42.94

E Galaxian™ . . . realistic hand-held space arcade game for 1 or 2 players.
FEATURES: Display shows aliens, galaxy ships, moving stars, bombs, missiles. Defend against aliens that dive, turn, even loop. 2 skill levels. Auto. digital scoring.
 48 T 14502—Uses 4 "C" batteries.* AGES: 8 and up. Ship. wt. 14 oz. 44.49

F Wildfire™ . . . electronic pinball game has variable speed selector for 3 skill levels.
FEATURES: Authentic pinball sound effects, lighted bumpers and targets, rollover lanes, kickout hole, digital scoring, 5 balls of light per player (up to 4 players). Even tilts! Uses 6 "AA" batteries.* AGES: 7 and up.
 Ship. wt. 1 lb. 10 oz.
 48 T 14034 42.94

*Batteries not included; order on page 380.



Avoid the Christmas rush—shop by phone! See page 318.

COLECOVISION

New at Sears!

Except Gorf (C)



(A thru J) The newest cartridges. All are warranted by Coleco except (E) Frogger is warranted by Parker Bros.; to write for free copy, see page 323. Shpg. wt. 6 oz.

Cartridge name and description	Catalog No.	Price
(A) Mr. Do. Life is just a bowl of cherries? Sure, you try harvesting this orchard. Cherry picking gets trickier as you get good. 1 player	49 C 75837	\$34.99
(B) Looping. Fly rings around hair-raising, air balloons to flight terminal. Once inside terminal, fly thru maze ridden with menacing enemies. 1 player	49 C 75834	34.99
(C) Gorf. Defend galaxy from evil robot Gorf by foiling his 5 schemes. 1 player	49 C 75836	34.99
(D) Victory. Defend your planet from paratroopers. 1 player	49 C 75825	34.99
(E) Frogger will be available after Oct. 14, 1983. Your frantic frog is jumpy as ever about crossing the street. 1 player	49 C 75700	39.99
(F) Buck Rogers: Planet of Zoom. You're pilot, navigator and gunner. Dodge missiles and saucers then attack alien mothership. 1 player	49 C 75842	34.99
(G) Sub Roc. Fight it out on ocean's surface with enemy ships, then climb into stratosphere for high-flying dogfights. 1 player	49 C 75843	34.99
(H) Front Line for Roller Controller (3). You're the last of your squadron being attacked from all sides. Step carefully over land mines to the remaining tank. 1 player	49 C 75844	34.99
(J) Time Pilot for Roller Controller (3). Aerial dogfights starts with prehistoric creatures advancing thru the ages to 21st century UFOs. 1 or 2 players	49 C 75841	34.99

First there's the basic console

capable of high-resolution graphics, precision game play plus a cartridge collection already featuring the cream of the arcade crop. Donkey Kong™ cartridge is already included! But what's a great game without great controllers? The basic controller comfortably combines an 8-direction joystick for split-second decisions with a 12-button keypad for more game options. All products are warranted by Coleco; to write for copy, see p. 323.

Atari 2600 compatibility

Hook up expansion module (2) and choose your action from the world's largest combined cartridge library!

Lightning-fast control, just like the arcades

Just roll your palm over the speedy Roller Controller (3) and watch your on-screen buddy react almost at the same instant. Spin free-rolling ball faster and the whole game tempo picks up. Table-top module has twin ports to hold regular ColecoVision controllers for keypad and fire functions. In Slither, the game that's included, you must blast your serpentine pursuers. Or play 2 new games, Front Line (H) and Time Pilot (J) sold at left.

From your easy chair, to driver's seat

The TV is transformed into the windshield of a high-performance racing machine. Before you is an incredible array of vividly detailed, hair-raising scene changes forcing you to make split-second, death-defying decisions. Table-top driving module (4) includes arcade-style steering wheel and foot-operated accelerator. Your regular ColecoVision™ controller mounts on the dash for smooth gear shifting. Turbo racing cartridge is included plus use module to play the new Destructor game (5).

Get a grip on the game

Your batter swings... ball and bat connect... it's a home run! Super Action hand-grip controllers (6) feature 4 fingertip trigger switches plus 8-direction joysticks. Speed roller lets you control game tempo. The included Baseball cartridge lets you choose close-ups of the batter-pitcher duel, insets of base action or a complete full-field shot.

(1) Console. Plastic, 15x9 in. UL listed for 110-120-volt, 60-Hz. AC. Reduced from our 1983 Spring Big Book, p. 684. Atari 2600 Compatible Module not incl. 49C75800—Wt. 8 lbs. 10 oz. Was \$199.99; \$159.99 49C75806—Extra Controller, Wt. 15 oz.\$24.99

Replacement Power Adapter
49 C 75805—Shipping weight 1 lb. 15 oz. ...\$24.99

(2) Atari 2600 Compatible Module. Console not incl. 49 C 75801—Shipping weight 2 lbs.\$59.99

(3) Roller Controller with Slither cartridge. 49 C 75807—Shipping weight 12 oz.\$79.99

(4) Driving Module with Turbo cartridge. Requires 4 alkaline "C" batteries, not incl., sold on p. 595. 49 C 75809—Shipping weight 2 lbs. 6 oz. ...\$79.99

(5) Destructor Cartridge for driving module. 49 C 75839—Shipping weight 4 oz.\$34.99

(6) Hand-grip Controllers with Baseball cartridge. 49 C 75838—Shipping weight 15 oz.\$79.99

(7) Football Cartridge for hand-grip controllers. 49 C 75822—Shipping weight 6 oz.\$34.99

(8) Rocky Boxing Cartridge for hand-grip controllers. 49 C 75840—Shipping weight 6 oz.\$34.99



Includes Slither

New at Sears!

Arcade-style Roller Controller



Bally®

PROFESSIONAL ARCADE



SAVE \$50
Bally pro home arcade
249⁹⁵



31-Galactic Inv.



30-Astro Battle



02-Dogpatch



12-Panzer Attack



12-Red Baron



21-Grand Prix



13-Clowns



14-Bally Pin



01-Baseball



21-Demo Derby



15-Football



22-Music Maker



20-Biorhythm



18-Blackjack



16-Letter Match



06-Star Battle



02-280 Zzzap



03-Sea Wolf



10-Amazing Maze



09-Speed Math

This is the home video game your family has been waiting for. Years of research and technological know-how have put the Bally Professional Arcade at the top of the video game system class. The programmable console includes three built-in games: Checkmate, Gunfight and Scribble—and it can also be used as a calculator. Built-in storage under dustcover for additional videocassettes (see below for the widest variety of games we've ever offered). Hand controls have 8-position switch plus rotary knob and trigger. Operates on any color or black and white TV—will not interfere with reception or picture when game is off. With controls for 2 players. Mfr.'s Warranty. * Was 299.95 in '81 Fall Book, page 662.

60 T 95080—Ship. wt. 5 lbs. 4 oz. now 249.95

Extra pair of controls for 3rd or 4th players.

60 T 95085—Ship. wt. 1 lb. pair 39.95

*Write for free copy of Mfr.'s Warranty, see pg. 322.

USE THIS CAT. NO. FOR ALL GAMES BELOW.

Z 60 T 95081—State code no. Wt. 3 oz. ea. 24.95

02—280 Zzzap™ and Dodgem™. Drive fast, rack up big mileage—but be quick behind the wheel. 1 player.

03—Sea Wolf™ and Missile. Are you good enough to get all the bombers or battleships? 1 or 2 players.

06—Star Battle™. Escape from enemy fire down a 3-D space tunnel—or turn and destroy! 1 or 2 players.

09—Speed Math and Bingo Math. 1 or 2 players.

10—Amazing Maze and Tic-Tac-Toe. 1 or 2 players.

THIS CAT. NO. FOR GAMES BELOW AND AT RIGHT.

Z 60 T 95082—State code no. Wt. 3 oz. ea. 29.95

01—Baseball, Tennis, Hockey, Handball. Great international competition for 2 players.

02—Dogpatch. Skeet-type shootout for 2 players.

12—Panzer Attack™, Red Baron™. Planes or tanks for 2.

13—Clowns™, Brickyard™. Knock 'em down. 1 to 4 pl.

14—Bally Pinball 1 & 2. Two pin games. 1 to 4 players.

15—Football. On D, blitz or stop the pass! 2 to 4.

16—Letter Match™, Spell 'N Score, Crosswords. 3 challenging word games. 1 to 4 players.

18—Blackjack, Poker, Acey Deucey. Vegas-style! 1-4.

30—Astro Battle. Your mission: destroy the invaders from space before they get your missile base. 1 pl.

31—Galactic Invasion. Mechanical insects will break formation and deftly destroy you! 1 player.

21—Grand Prix, Demolition Derby. Jockey for position at Le Mans or survive the crash course. 1 or 2 players.

22—Music Maker I. Create electronic music. 1 player.

20—Biorhythm. Enter your birth dates and the computer calculates your ups and downs. Party fun! 1-2 players.

Bally Basic and Audio Interface Combination. This single unit allows the user to create his own programs and record them on any cassette tape.

60 T 95088—Ship. wt. 1 lb. combo 49.95

ODYSSEY 2

New at Sears!

The keyboard is the key

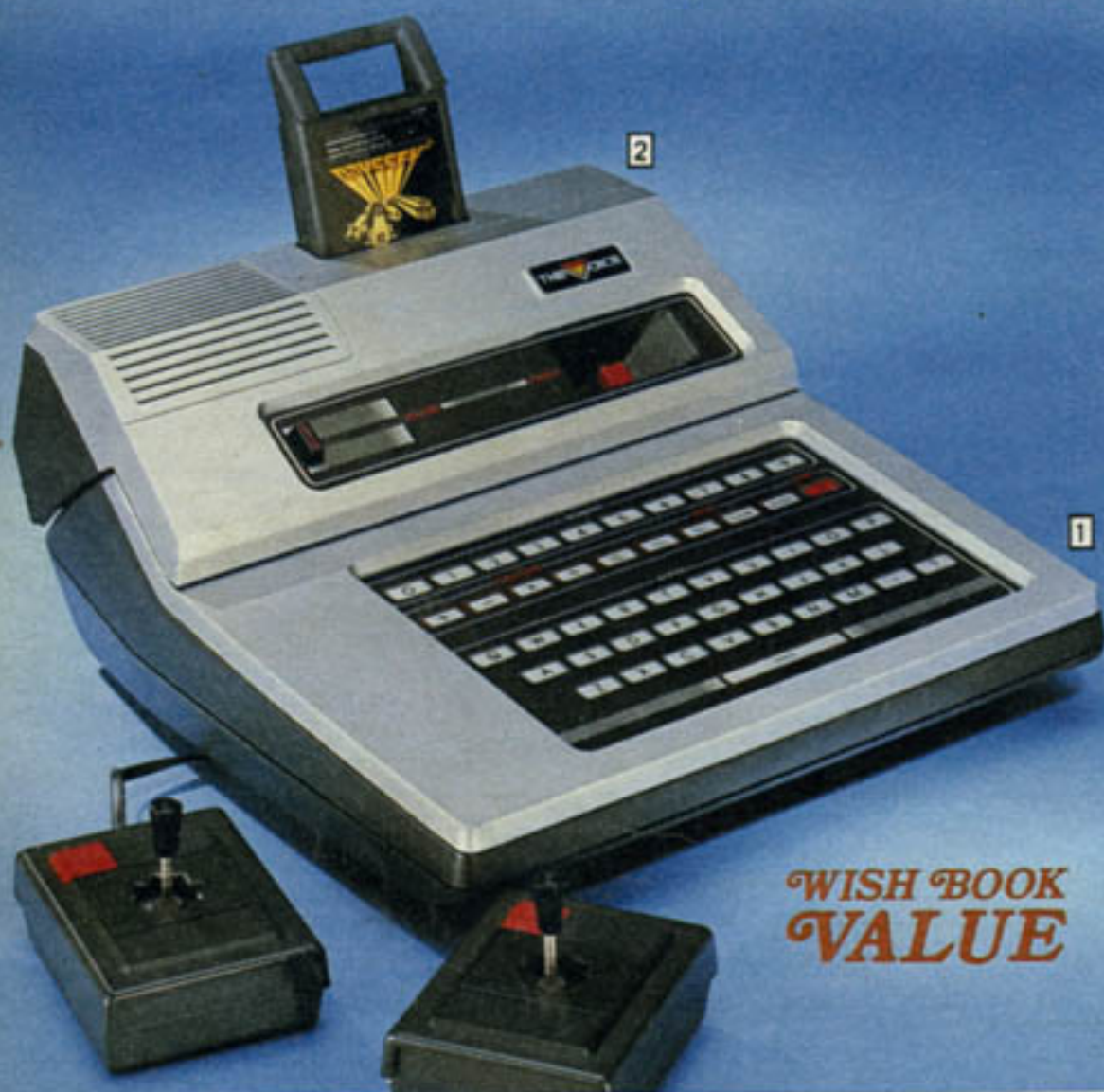

WISH BOOK
VALUE

Console **Cut \$100 \$49⁹⁹** | Voice Module **Cut \$30 \$49⁹⁹**

(1) The console combines the strategic scheming of a keyboard-controlled computer, with the exciting split-second action of a joystick-controlled game. Use the 49-character membrane keyboard to play games and program game variations, time limits and skill levels. Two hand-held joysticks have 1 fire button each. Cartridge with 3 different games, Spin-Out, Speedway and Crypto-Logic, included. Plugs into any TV. Plastic console case. Voice module (2) not included. UL listed for 110-120-volt, 60 Hz. AC. Warranted by Odyssey, see p. 323. Reduced from 1982 Wish Book, p. 641. 49 C 75900—Shpg. wt. 10 lbs. Was \$149.99; Now \$49.99

(2) Voice Synthesis Module, when used with talking cartridges, will produce calm or excited voices that react to game situations. Plastic case fits into console cartridge receptacle. Console and cartridge not included. Warranted by Odyssey, see page 323. Reduced from our 1982 Wish Book, page 641. Shipping weight 6 pounds. 49C75905. Was \$79.99; Now \$49.99

(3 thru 17) Cartridges are warranted by Odyssey except for (3) and (5) which are warranted by Imagic, see page 323. Wt. 5 oz. ea., except for (8) which includes gameboard and player tokens and weighs 1 lb. 14 oz.

Cartridge name and description	Catalog Number	Price
(3) Demon Attack. Fend off overhead creatures. When hit, some divide and keep coming. Don't even blink—they'll get you. 1 player.	49 C 75980	\$27.99
(4) Turtles*. Papa Turtle carries turtles home before nasty beetles bug'em. 1 or 2 players.	49 C 75978	27.99
(5) Atlantis. Save the fabled underwater isle from alien assault. 1 player.	49 C 75981	27.99
(6) Killer Bees*. Only you can stem the swarm of these invading insects. 1 or more players.	49 C 75979	27.99
(7) K.C.'s Krazy Chase*. Run for your life in a maze you control. Use with Voice Module (2) and voice will warn when opponent approaches. 1 or more players.	49 C 75973	27.99
(8) Quest for the Rings. Work to recover 10 rings of power that lie in dungeons and caves guarded by evils. Combines computer and game board concepts. 1 or more players.	49 C 75951	39.99
(9) Attack of the Time Lord. You're the invader. Stay the Lord to win. 1 or 2 players.	49 C 75977	27.99
(10) P.T. Barnum's Acrobats*. One daredevil jumps, the other grabs at points. 1 or 2 players.	49 C 75976	27.99
(11) Pick Axe Pete*. Crush boulders and climb ladders to find keys to open new mines. 1 or more players.	49 C 75930	27.99
(12) Nimble Numbers NED*. Teach math thru drill and reward. Answer problem correctly and jump barrels. 3 activities, 5 levels each. Voice tells when you are right. 1 player.	49 C 75974	29.99
(13) SID the Spellbinder*. A spelling bee of drill and reward. When you spell the word correctly, you get target practice. Voice tells when you are right. 1 player.	49 C 75975	29.99
(14) Smithereens*. Use voice module. Catapult boulders on enemy castle. 2 players.	49 C 75972	27.99
(15) Alien Invader. Disintegrate enemy marching down to destroy you. 1 player.	49 C 75913	19.99
(16) Freedom Fighters. 3 different game modes test your piloting, evading and combat skills and reflexes as you rescue your comrades from confinement. 1 to 2 players.	49 C 75931	27.99
(17) Monkeyshines. Go ape trying to tag monkeys as they climb and swing thru bars. It's monkey business galore when you control the bars. Up to 4 players.	49 C 75932	27.99

*Use with voice module (2) for enhanced arcade sounds or voices



Demon Attack

3



Turtles

4



Atlantis

5



Killer Bees

6



7



8



9



10



11



12



13



14



15



16



17

for you and your family

The new Atari 400™ Personal Computer System can teach, play games and help organize your life —but it doesn't take a genius to use it

For many people a computer is one of those exotic "number crunchers" that calculates satellite orbits or audits tax returns in the blink of an eye. Until now, the idea of actually owning and operating one of the things (even a small one) didn't seem to be practical or even possible for the average person.

The Atari 400™ personal computer system lets a novice begin using the computer for exciting, educational and useful purposes by simply placing pre-programmed cartridges (sold separately) into the console and pressing a few buttons. Of course, the system is also designed to keep on challenging you for years to come because it is a powerful general purpose computer you can program yourself.

LIKE EVERY COMPUTER THIS ONE PERFORMS MANY MATHEMATICAL FUNCTIONS WITH UNCANNY SPEED

$$\left(\frac{1/2 - 3/2}{2.3 - 1}\right) \left(\frac{4^3 - 3^3}{11/4}\right)$$

Inside the sleek computer console there's a powerful electronic brain and memory that can store and manipulate over 8000 bytes ("8K" in computer lingo) of information at a time. Among other things, this power can be used to perform a wide variety of arithmetic and advanced mathematical computations with numbers up to 10 digits long. In a more practical vein, you can use the computer's capacity to store names, numbers, addresses, even recipes then recall and sort them in an infinite variety of ways. But that's not all. Look what can be done using the optional cartridges and cassettes sold on the facing page.

IT CAN ALSO BE A TEACHING MACHINE

By inserting the Educational Cartridge into the console you've programmed the brain to teach a variety of courses.



TAKE A COURSE IN SOCIOLOGY

Use one of the Educational Cassettes with the Program Recorder (sold on facing page) and the system automatically begins teaching by using a printed text, spoken voice and simple graphics. As the lesson progresses the computer tests you by asking multiple-choice questions. Answer questions by pushing keys on the console. If you answer incorrectly, the computer lets you know. If you are correct, the computer continues the lesson.



In years to come additional cassettes will be offered on subjects from auto mechanics to foreign languages. Like having a kindergarten thru university teacher in your living room.



PLAY 1, 2, 3 OR 4-MAN BASKETBALL

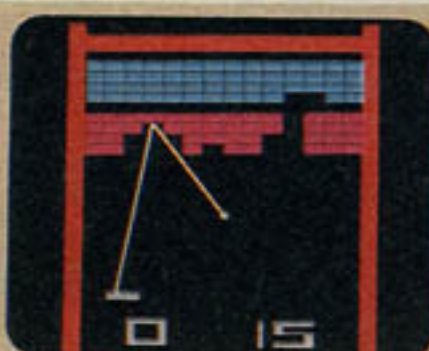

TRY 1 TO 4-PLAYER SUPER BREAKOUT

PLAY GAMES MADE FAMOUS BY ATARI

The Game Cartridges make full use of the computer's ability to add lively action, color and sound as well as a wide variety of game options to challenge and entertain you.

With up to 4 optional Joystick Controllers (sold on facing page) you and your friends can play life-like basketball by running, jumping, blocking shots, dribbling and shooting baskets. Score and elapsed time is shown on the screen.

With up to 4 optional Paddle Controllers you and your friends can compete in exciting Super Breakout. Or, if you choose, play either game against the computer.

CREATE BEAUTIFUL KINETIC ART USING THE LIFE CARTRIDGE

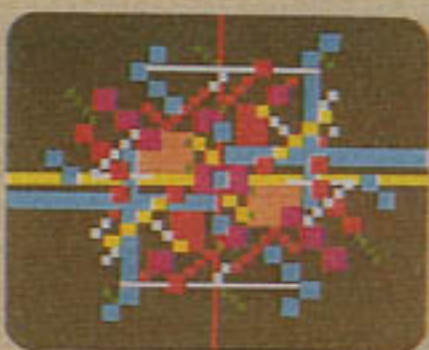

WATCH COLORFUL PATTERNS DEVELOP

Translating electronic impulses into exciting full-color graphic displays is one of this system's many talents. Using the Life Cartridge and up to 4 optional Joystick Controllers select the color, shape and direction of graphic elements and watch the computer create fantastic arrangements that grow and evolve like exotic blossoms on your TV screen.

YOU CAN EVEN COMPOSE MUSIC

Plug in Music Composer Cartridge, arrange or change notes on your TV screen with an opt. Joystick Controller. Enter key and tempo, too. Touch button to hear tune played. Save music on blank cassette using Program Recorder.



YOUR TUNE IS SHOWN AND PLAYED

DO YOUR OWN PROGRAMMING

The cartridges and cassettes sold on the facing page and those to come in the future make using a computer useful and fun with little need to understand just how the computer works. Sooner or later, though, you'll get the itch to create your own games, handle business and home finance problems, keep household records, mailing and recipe lists and a-thousand-and-one other applications that will develop over the years. That's why the system includes a Basic Language Cartridge, Basic Language Instructional Cassette and a 332-page Programming Textbook. With them you can "talk" to the computer on its own terms. Using the Program Recorder you can store your own specialized programs on ordinary audio tape cassettes for later use.

THE BASIC SYSTEM IS VERY VERSATILE

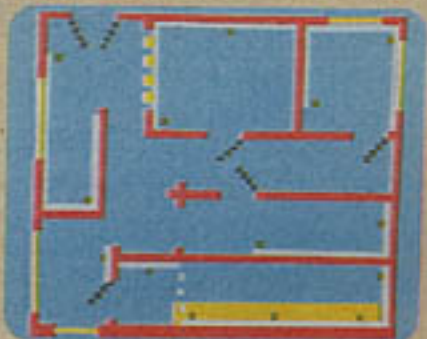

PROGRAM PICTURES, CHARTS, GRAPHS

You enter, alter and manipulate text, graphics and sound input using the 57-key touch sensitive typewriter layout and 4 special function keys. Type in upper and lower case, change colors, sound and display 44 different graphic symbols. Insert optional program cartridges into console to add specialized instructions to memory.

The 13 1/2 x 11 1/2 x 4 1/2-in. high console has input jacks for up to 4 controllers plus the Programming Recorder. A TV switch box lets you attach the console to any TV set. Console operates on 9 v.; AC adapter incl. System also incl. Basic Language Cartridge and Instructional Cassette, textbook and operating manual.

ORDER INFO: Order Program Recorder, Cartridges, Controllers and Cassettes on facing page. T3 C 7601C—Shpg. wt. 12 lbs. \$549.00

Gifts under \$75



(A) *Zaxxon™*. \$10 REBATE from Coleco. Price after rebate \$44.99. See p. 545. Maneuver your space fighter over an alien landscape to the attack! Features a 3-dimensional display and 2 skill levels. Plastic cabinet is 22½x17½x10½ inches high. Requires 4 "D" batteries (not included, see p. 505). For ages 8 and up. Warranted by Coleco. Write for free copy, see page 323. Wt. 2 lbs. 2 oz. 49 E 65124... Full price \$54.99

(B) *Sueded, split leather Jacket*. Was \$79.99 in our 1982 Fall Big Book, p. 570. Cowhide shell with knit nylon trim, woven nylon lining. Back length is about 25 inches. Professionally leather clean. Imported. *State even chest size 36 to 46 inches.* X 45 E 62021F—Taupe, X 45 E 62022F—Brown. Shpg. wt. 3 lbs. 2 oz. . . \$59.99



(C) *Hand painted Nativity Set and Stable with Music Box*. Save \$15 when you buy both. Separate prices total \$89.98. Nativity set includes seven resin figures. The tallest is 6½ inches high. Hand crafted wooden stable has a wind-up music box that plays "Silent Night." 18½x9½x13 in. high. Both items imported. See "N" note, p. 323. 71 E 97378N—Nativity Set with Stable. Wt. 12 lbs. 8 oz. . . \$74.98
71 E 97375L—Nativity Set alone. Wt. 5 lbs. . . \$69.99
71 E 97377N—Stable alone. Wt. 7 lbs. 8 oz. . . 19.99

(D) *12-inch diagonal measure Black and White TV*. Was \$114.95 in our 1983 Spring Big Book, p. 692. Works on AC power or plugs into your vehicle's lighter with 7-ft. DC adapter cord (included). Quick-start picture tube. Plastic cabinet. 15½x11½x12½ in. high. UL listed; 120-volt, 60 Hz. AC. 6-ft. cord. Imported. See our 1983 Spring Big Book for Sears specific written warranty or write for free copy, p. 323. See "N" note, p. 323. 57 E 5023N—Shpg. wt. 19 lbs. . . \$74.95

(E) *Limited Edition Scrimshaw Collector's Knife*. Lockback knife with original Alaskan scene carved into bone handle. Each individually crafted knife is signed and dated by Scrimshander. Only 1,000 are available, each with its own serial number. Includes certificate of origin and documents for registering knife with manufacturer. Knife is 3¼ in. long when closed, has razor-sharp steel blade. Comes in velour-lined gift box. T 9 E 95122—Shipping weight 6 oz. . . \$70.00

(F) *Great Low Price for a Coinmaster® Metal Detector by White's*. Perfect for the novice treasure hunter. . . one control for ease of operation. Helps locate most metals, coins. Six-inch loop. Built-in speaker and headphone jack. Low battery alert. Uses 9-volt battery (incl.). Warranted by White's, see p. 323. T 6 E 59638—Shpg. wt. 2 lbs. 12 oz. . . \$69.99

(G) *Genuine Pigskin Leather Attache for Him or Her*. Was \$89.99 in our 1983 Spring Big Book, p. 407. Has two brass-plated combination locks. Interior lined with coordinating leather-look vinyl. Full-width file pocket has adjustable snap. Three accessory pockets for business cards or calculator. I.D. tag. 17x12½x3¾ in. deep. Imported. *State color no.:* B—dark brown. 14 E 8098H—Shpg. wt. 6 lbs. . . \$69.99



 *Have Sears gift wrap your presents for you!* You can order this service for any item with the holly leaf symbol after its price. Your holiday packages will arrive boxed and wrapped in red paper, ready to give. Or send them directly to the recipient with our Ship-A-Gift service on p. 322. For Christmas delivery, order before December 12, 1983. 39 E 10075... Each package \$2.00



Our new 2-4-6-hour VCRs let you make your own

1-day/1-program
programmable
touch control VCR

989⁸⁸

Includes remote pause



A



Multi-function remote control for
arm chair ease of operation



B

2-week/8-program programmable VCR
with wireless remote control

1389⁸⁸
Available after Nov. 1, 1981

Portable 3-way operation
touch-control VCR

1189⁸⁸

Includes remote
picture scan,
pause, pause/still,
frame advance



C



Tape action outside!



See our NEW Video Disc Player
on the back cover!

1 Buck Rogers® Target Game. A 360° space shooting gallery! Alien craft "travel" throughout the room—up, down, at angles. Random, endless targets sound when hit—just keep firing with your X-fighter gun. 10 in.-diameter plastic Light Star projector is 11 in. high. Uses two "D" and two 9-volt batteries—not incl., sold on p. 461. Ages 8 and up. XU 925-6447 A—Del. wt. 3 lbs. **37.99**
*1979 Robert C. Dille

2 Flash. Five different games of electronic arcade action for 1 to 5 players. Toss bean bags at the space-age "dartboard"—hits produce a light and sound show, plus automatic scorekeeping. The target can hang on a wall or stand. Comes with 6 bean bags. Plastic, 14½x7x17 in. high. Uses 4 "D" batteries—not included, sold on p. 461. Ages 8 and up. Del. wt. 5.50 lbs. Will be \$55.99 on January 24, 1981. XU 925-6439 A **NOW 51.99**

3 Shoot-Out in Space. A ray of light from the space gun hits the bull's eye on the revolving space station and ZAPI—an enemy rocket pops off. Increase the challenge by making the bull's eye smaller and smaller. 28½ in.-long gun has detachable stock so it can be used as a pistol—light beam is effective on target from up to 30-ft. away. Revolving space station, 5 rocket targets. Uses 4 "AA" batteries—not incl., sold on p. 461. Ages 6 years and up. Was \$19.99 in our Christmas '79 Catalog. Delivery weight 2.40 lbs. XU 925-6942 A **NOW 14.99**

4 Electronic Two-Man Skeet.* A ball of light's projected on wall—it moves, disappears, reappears. Realistic "shoot" and "hit" sounds. Nine different games; each can be played solo or with two. Degree of difficulty in solo game can be adjusted. 32½ in.-long shotgun looks realistic. 11½x10x6-in. projector. Plastic and metal. Not fully assembled—needs pliers, screwdriver. UL listed for 110-120 volts, AC. Ages 9 and up. Will be \$92.99 on January 24, 1981. Delivery Class A—see page 364. 15-lb. rate. XU 925-9631 A **NOW 88.99**

5 Quickfire.* Electronic shooting gallery for 1 or 2 players. 6 different games, each with 3 skill levels. Shoot at lights and sounds that come in—or out—of sequence. Skill levels let each game be set from simple to almost impossible. Automatic score read-out. Gun has 15 ft. disconnecting lead wire for counting shots. Plastic target is 14½x4½x14 in. high. Uses 6 "D" and 2 "AA" batteries—not incl., sold on p. 461. For ages 6 years and up. Del. wt. 3.75 lbs. XU 923-9708 A **57.77**

6 Tin Can Alley. Detailed gun has the look and heft of a real target rifle. Cock, aim at the star on a can, squeeze off a BANG! A beam of light is "fired." If you've aimed well, it activates a photocell mechanism that pops the can over. Shoots from up to 25 ft. away. Plastic and metal rifle is 39 in. long. Comes with 5 cans. Uses one 9-volt and 3 "D" batteries—not included, sold on page 461. For ages 8 and up. Will be \$41.99 on January 24, 1981. Del. wt. 6.40 lbs. XU 924-8303 A **NOW 39.99**

7 Stellar War Dual Target Game. Electronic competition as opponents blast away with 9½-in. ray guns at two space-scene targets. Automatic scorekeeping in LED read-out, space blast sound on each hit. Target is 13½x2x9¼ in. high. All plastic. Uses one 9-volt and 4 "D" batteries—not included, sold on page 461. Imported from Hong Kong. For ages 6 and up. Delivery weight 3 lbs. XU 925-6488 A **23.99**

TOYS AREN'T JUST FOR CHRISTMAS. Save this catalog. Order toys from pages 375-527 until August 15, 1981.



A
Double Pitstop
Tabletop Pinball
—battery powered
25⁴⁹

B
Star Quest
Electric Pinball
54⁸⁸

A Battery Powered Double Pitstop Pinball. Two players each work their own game. Automatic dual scorekeeping, independent flippers, light and sound action. A secret tunnel sends a steel ball that's hit too hard over to the other player's side to run up his score. Adapts for single player. Plastic. 31x17x9 in. high. Uses 2 "D" batteries—not incl., sold on p. 461. Ages 8 and up. Delivery weight 5 lbs. XU 925-6561 A **25.49**

B Star Quest Electric Pinball.* Professional-type loading mechanism, 10 scoring bumpers for plenty of action, 4 bonus-score channels. Bell rings and lights flash on scoring, 2 independent replay flippers. Automatic scoring to 100,000 on the futuristic "TV" monitor. Manual scoring to 500,000. Made of plastic and steel. Steel balls. Legs fold for storage, 32x17¼x50 in. high. UL listed for 110-120 volts, AC. Some assembly required—use screwdriver and pliers. Ages 8 and up. Delivery Class A—see page 364. Wt. 22 lbs. XU 925-5613 A **54.88**

C Star Mission Battery Pinball. Two independently controlled flippers send the steel ball into "outer space" for lots of light-flashing, bell-ringing scoring. Automatic score dial. Plastic. 20x10½x12 in. high. Uses 4 "D" batteries—not incl., sold on p. 461. For ages 8 years and up. Delivery weight 4 lbs. XU 925-6512 A **15.49**

D Knock Down Pinball. Control the independent flippers to send the steel ball into any of five slots. The ball knocks a block out of that slot's stack; count up the knocked-out blocks to get the score. Plastic. 15½x7½x8 in. high. Ages 8 and up. Delivery weight 2.10 lbs. XU 924-4969 A **9.88**

E Pop-Up Pinball. Filled with action. Shoot the plastic balls and work the flippers; when the ball drops into any of the 6 holes, a bell rings and up comes a zany policeman who pops the ball out again! Made of plastic. 13x7x18 in. high. Ages 3 and up. Will be \$18.79 on January 24, 1981. Delivery weight 3 lbs. XU 925-5670 A **NOW 17.79**

*Caution: electric toy—see note on page 465. Warranted by manufacturer, see page 363.



C
Star Mission
Pinball
15⁴⁹

Flipper-Powered
Knock Down
Pinball
9⁸⁸
D



Pop-Up Pinball **17⁷⁹**
E



59.99-199.99

Get all your hardware and software together with a computer workcenter... the perfect gift for a computer owner

A No money down, \$15 a month.* Contemporary workcenter pulls all your computer components together, plus you get plenty of storage space! Perfect for your home or office. Extra-large pull-out drawer for accessories. Beautiful Bartonwood vinyl laminate finish, accented with adjustable dark brown vinyl laminated shelves. Steel floor glides for leveling. Desk is about 48 in. high x 49 in. wide x 24 in. deep. Shelves are about 24 in. wide x 12 in. deep. Shipped unassembled.

63 G 13919 R—Ship. wt. 60 lbs. 199.99

B Printer stand is the ideal companion for (A) and (C). Large paper shelf with a paper feed slot behind. Steel floor glides for leveling. Accepts most printers. Finished in Bartonwood vinyl laminates. About 27 in. high x 23 in. wide x 19 in. deep. Shipped unassembled.

63 G 13918 R—Ship. wt. 38 lbs. 59.99

C Modern computer workcenter keeps all your components organized and at your fingertips. Large storage area below for accessories. Rounded rail design for operator convenience. Steel floor glides for leveling. Finished in warm Bartonwood vinyl laminates. About 37 in. high x 37 in. wide x 19 in. deep. Shipped unassembled.

63 G 13917 R—Ship. wt. 71 lbs. 99.99

*Montgomery Ward Credit customers: This purchase may change your monthly payments depending on the highest balance on your account. Does not apply to AZ, NM and OR residents. See page 497.

Computer systems are sold separately on pages 516-523.





He shoots, he scores!



Electronic timer and scoreboard



Sturdy plastic hockey players



A



B

B Play-Off Hockey. One forward on each team can operate behind goal. Centre forwards move in new pattern and can bypass each other across Red line. More puck passing combinations. 3 dimensional players. Nylon geared pivots. Smooth plastic playing surface. About 35½ x 19½ x 3¼".
492 562 739 DL—Each 129.99



C

SAVE \$2

C Hockey Game with authentically marked NHL® players. About 28 x 17 x 3½" high. Sears reg. 26.99.
492 562 984 DL—Each 24.99



D

D Deluxe Hockey Game for hours of fun and excitement. NHL® plastic players. Includes score tower, puck dropper, puck and 'Stanley Cup'. Measures about 36" long x 21" wide x 4" high.
492 562 983 DL—Each 44.99
As Above but with legs. About 27" high.
492 562 982 DL—Each 54.99



TIGA

A Electronic Hockey with timer that counts minutes and seconds remaining in optional 3 or 5 minute periods. Goal scored stops timer until next face-off. Score flashes throughout period. 3-dimensional players—forward can clear puck from behind net. Nylon gears, smooth surface. Measures about 35½" long x 19½" wide x 3¼" high. Uses 6 'C' batteries (not included—see page 398).
492 562 987 DL—Each 189.99

ship a gift

to anywhere
in Canada...
for details,
see page 372



The Horses are at the Post!
Pick your favorite
and cheer him
on to victory

1
17⁹⁹

1 HORSE RACE GAME. Completely portable so you can enjoy the "sport of kings" just about anywhere—at the beach, on the road, etc. Just push the switch and the six horses start their race for the finish line. As each crosses the finish line, his number pops up. Uses 2 "D"-cell batteries—not incl., order on page 370. Plastic. For 1 to 6 players. X 641-7513 A—20½x7x4 in. high. Mail. wt. 4.25 lbs. 17.99



18⁹⁹

It's Game, Set,
and Match with
Electronic Magic
Tennis Game

2

■ Portable table-top game lets you enjoy the sport anywhere, in any weather

2 TURN IT ON and the "ball" (blip light) starts moving across screen. Turn your dial and your "racket" moves along end line to return opponent's volleys. When ball hits endline, scoreboard automatically indicates a point. First person to make his opponent miss the ball 11 times wins. Counterdial resets scoreboards. Uses 4 "D"-cell batteries—not incl., order on page 370. For 2 players. X 641-7505 A—Molded plastic. 20¾x12¾x4 in. high. Mail. wt. 6 lbs. 18.99

Giant Checkers
Game Rug
6⁹⁹

GREAT FOR HOME, BEACH, at the pool, etc. Large 27-in. square red and black acrylic pile—machine washable. Includes 24 giant-size, 2¾ in. diameter, red and black plastic checkers. For 2 players. Mailing weight 2.40 lbs. X 641-4999 A 6.99



Shogun exciting digital game

■ The digit on each piece determines how many squares it can move to try to capture your opponents king. **BUT WATCH OUT,** every time a piece is played, the digit may change!

DURABLE INJECTION-MOLDED PLASTIC board (12½x12½x1 in.) and red and white playing pieces. For 2 players. Instructions. Mailing weight 3.25 lbs. X 641-7562 A 11.88



11⁸⁸

Othello . . .
combines the
simplicity of
checkers with the
strategy of chess

15⁸⁸

TOURNAMENT OTHELLO. Object is to make your disc color the dominant on the board by carefully capturing your opponents discs. Wood-tone, rugged styrene with slip-resistant, felt-look cloth playing area. 2 slide-away disc storage compartments. 64 black/white discs, complete instructions. Measures 18x16x3 in. high. For 2 players. X 641-7554 A—Mailing weight 2.90 lbs. 15.88



An Old Favorite
Takes a Turn
for the Better with
Turntable Tripoley®

DELUXE VERSION of the popular game. Combines poker, hearts, and Michigan rummy. Ball-bearing, high-impact styrene turntable with slide-and scratch-resistant bottom has storage space for chips. 200 chips, cards, instructions included. For 2 to 9 players. Measures 14½x14½x2½ in. Mailing weight 3.25 lbs. X 641-6358 A 12.66



12⁶⁶

Super
Mastermind
challenges
you to break
the hidden
code using
logic and
deduction



3

8⁸⁹

3 ADVANCED VERSION OF THE POPULAR MASTERMIND CODE GAME. Object is to find the hidden code from 59,049 possibilities using logic and your opponent's clues. High-impact, injection-molded plastic board (14½x6½x1½ in.), shield, and pegs. Board has built-in scoreboard and 2 handy storage compartments. Complete instructions in 10 languages. For 2 players. X 641-7539 A—Mailing weight 1.20 lbs. 8.89

Four Sight . . . a game where planning
ahead can make you a winner



4

4⁵⁰

4 FOUR SIGHT. You and your opponent place the black and white squares on the 13½x6¾x1½ in. playing board. At any time you can place your template on the board. If 3 of your color and 1 of your opponent's color shows, you win. 4 different templates included. High-impact, injection-molded plastic board, templates, and playing pieces. Instructions. For 2 players. X 641-7547 A—Mailing weight 1 lb. 4.50

Mary Hartman,
Mary Hartman®



5

5⁴⁴

A zany board game starring the
characters from the popular TV show

5 MARY HARTMAN, MARY HARTMAN. Re-creates the trials, tribulations, hopes, and triumphs of 8 popular Fernwood residents. Game includes 17x17 in. playing board, 28 episode cards, 36 action cards, pair of dice, 11 character cards, and complete instructions. For 2 to 4 players. X 641-7521 A—Mailing weight 2.25 lbs. 5.44
©1977, T.A.T. COMMUNICATIONS COMPANY.
All rights reserved.

\$28⁹⁹

There's no limit to what youngsters can achieve when you make learning fun... and the popular, educational Computron™ does just that!



The Computron will help your child develop math skills, create musical awareness and expand his or her powers of logic.

The Computron™ electronic learning toy also helps children learn the alphabet and improve their spelling. 10 games and an amazing 25,000-problem memory offer lots of challenges for young minds. Problems appear on the easy-to-read LED screen as children use the colorful lesson book to follow along. The touch-sensitive keyboard responds quickly to each entry and the correct response wins a musical salute!

Children can create their own songs on Computron's full musical scale or play the tunes provided in the lesson book. Unit automatically shuts off when left unattended. Requires AC adapter (2) below, or six "C" batteries, sold separately on page 404. For ages 5 to 12 years.

49 N 17702—Shipping weight 3 lbs... \$28.99

2 AC power adapter for (1). UL listed. Not recommended for ages under 5.

49 N 17995—Shipping weight 10 oz... \$9.99



Quiz-a-tron is an entertaining, educational playmate

\$29⁹⁹



See our new Talking Computron™ on the back cover of this catalog...

\$5 less
thru December 15th

3 Learning is fun with the Quiz-a-tron. Uses a combination of games, lights and sounds to help your child develop skills in math, logic, words and more. It responds to correct answers with a musical salute. 3-speed settings. Constructed of plastic. Requires 8 "AA" batteries, sold separately on page 404. Imported. Additional booklets available below. For ages 4 to 8 years.

49 N 17779—Shipping weight 1 lb. 12 oz... \$29.99

Extra question booklets for (3). Each 38-page booklet contains 380 questions to challenge children 4 to 8 years.

49 N 17796—Level I, ages 4 to 5 years

49 N 17797—Level II, ages 5 to 6 years

49 N 17798—Level III, ages 6 to 7 years

49 N 17799—Level IV, ages 7 to 8 years

Shipping weight 8 oz... Each \$2.99

Save \$2 on complete set of question booklets for (3), levels I thru IV. Separate prices total \$11.96.

49 N 17789—Shipping weight 2 lbs... Set \$9.96

Toys 'n Kids:

Simple electronic learning toys help pre-school age children with cognitive skills as well as manual dexterity. Games with voice synthesis literally play "with" the child because they actually comment on the child's performance in an encouraging manner. Excerpted from: THE ABC'S OF TOYS & PLAY, Toy Manufacturers of America, Inc.

MISS A SALE? Not at Sears!

You AUTOMATICALLY get the lower price if the item you order is currently on sale in another Sears catalog



Mattel Intellivision® Master Component

TV not included
Poker Black Jack
shown on screen
(included with system)



269⁹⁵
Charge it—
see page 363

The Computer-based System that Transforms Your Home TV into a Family Center for Games, Entertainment, and Education

Intellivision Master Component. Features a powerful 16-bit microprocessor, a broad color palette, great visual clarity, and a wide range of sound effects including 3-part harmony. Play against the built-in computer or against another player. Hours of challenge with each different cartridge (order below). Two controllers included with console combine keypad and action controls in one. An overlay card included with each cartridge fits over the keypad with instructions for that game. Control disc lets you maneuver objects on screen in 16 different directions. Launch and fire buttons are on both sides of controller for right/left-handed players. Includes Las Vegas, Poker and Blackjack cartridge. Console has brushed metal and simulated wood-grain trim. Measures 15½ x 9 x 2½ in. 110-120V, AC. UL listed.
X 917-3741 A—Delivery weight 6 lbs **269.95**

Cartridges for Varied Entertainment



Backgammon



Math Fun



Space Battle



Basketball



Baseball



Armor Battle



Football



Las Vegas Roulette

Your
Choice **29⁹⁵**



Tennis



Horse Racing

SAVE 10% When You Buy any 2 or More Cartridges†

Entertainment Cartridges for Intellivision System. Instruction booklet and 2 controller overlays included. State catalog number for cartridge when ordering. Delivery weight 0.50 lb. Each **29.95**

- X 917-3790 A—Backgammon.* Choice of beginner to champion.
- X 917-3774 A—Math Fun.* Game entertains, helps children improve skills.
- X 640-2705 A—Space Battle.* You must outwit computer-controlled invaders.
- X 917-3766 A—Basketball.** 2 teams compete for 48 minutes of excitement.
- X 917-3758 A—Baseball.** Teams play with bats cracking, crowd roaring.
- X 917-3782 A—Armor Battle.** You command the spearhead.
- X 640-2655 A—NFL Football.** 2 animated teams. 2 full halves. 60 minutes of grid-iron fun. Computerized scoring, game sounds, music, and more.
- X 640-2663 A—Las Vegas Roulette.* Casino fun right on your TV. Sights and sounds of Vegas appear to surround you. The electronic croupier gives you the news!
- X 640-2689 A—Tennis.** The realism of championship tennis recreated for this exciting game—a crowd whose cheers, and faces follow the action.
- X 640-2697 A—Horse Racing.** Like a real day at the races. Watch the parade, see the odds change, place your bet, and they're off. (Not available before October 1, 1980.)

*Play against the computer or another player.
**Two-player game.

†To order, state catalog numbers, add up mailing weights, and pay 26.95 for each cartridge.



26⁸⁸
TV not included



18⁸⁸
TV not included

Telstar Marksman by Coleco

• Play six video games (games included) with 3-in-1 photo-electric rifle

Telstar Marksman includes 6 exciting TV games in full color. Hockey, Tennis, Handball, Jai Alai, Skeet, and Target Practice. 3-in-1 photo-electric rifle can be used as a pistol, a target pistol, or a rifle. Hard-plastic housing of console measures 11¼ x 5½ x 2 in. Operates on two 9-volt batteries (not included, see page 461), or on an AC adapter (order at right).

X 640-2739 A—Delivery weight 4.25 lbs **26.88**

Telstar Colortron by Coleco

• Uses realistic, electronic sound effects

Telstar Colortron includes 4 fun-filled color TV games - Hockey, Tennis, Handball, and Jai Alai. Play by yourself, or with friends. Hard-plastic console measures 11¼ x 5½ x 2 in. Game appears in color on a color TV. Operates on two 9-volt batteries (not incl., see page 461), or AC adapter (Order below).

X 640-2721 A—Delivery weight 4.25 lbs **18.88**

AC Adapter, UL listed.

X 917-1984 A—Delivery weight 0.50 lb **5.95**



NEW AT SEARS! THIS VHS MOVIE CAMCORDER WITH ALL ACCESSORIES FOR JUST \$47 MONTHLY* HAS AUTO FOCUS AND USES STANDARD VHS TAPES TO RECORD UP TO 2 1/2 HOURS of Christmas memories (with sufficient battery power). You can also use the adapter (incl.) to connect it to any TV and play prerecorded VHS tapes, so even if you don't have a VCR, you can enjoy rental movies at home! This lightweight camcorder has convenient pause remote, 1-hr. battery with AC adapter/recharger, plus A/V cord which connects to TVs with A/V jacks to even record TV programs! 2 1/2-in. electronic viewfinder has review button to let you play back the tape to see what you've just recorded. Has f1.2 lens with 6x zoom focus. 1/2-in. Saticon® tube performs even in light as low as 7 lux. Earphone, shoulder strap and carrying case also incl. Tapes not incl. Weighs just 5.3 lbs. without the battery. See Note on p. 607.

O 57 E 5372C—Shpg. wt. 7 lbs... **\$1289.99**

*See page 338.

For items with a "D" prefix, allow a minimum of 10 days for delivery

\$1289⁹⁹

Extra one-hour rechargeable battery.
O 57 E 53994—Shpg. wt. 1 lb... **\$39.99**
Two-hour rechargeable battery to double your recording time.
O 57 E 53995—Shpg. wt. 2 lbs... **\$49.99**

There's more for your life at
SEARS

A Is it 'Ein' or is it 'Stein'?... It's 'Einstein' the computerized memory game! Object is to remember correct sequence of Einstein's lights and sounds. If you're successful, Einstein will add another light and sound—if you miss sequence, Einstein emits 1st four notes of Beethoven's 5th. Four levels of skill. Features automatic playback of longest game.

492 523 591—Uses 4 'C' cells*. Each 24.99

B Compu-Bowl—a challenging hand-held electro-mechanical bowling game! By skillfully controlling 'straight ball' and 'curve ball' buttons you can score a strike or spare, which automatically lights up crown score indicator. Bell rings when you score a strike. Hear ball as it 'rolts' down alley.

492 523 597—Uses 2 'AA' cells*. Each 14.99

C 'Merlin' plays six light and sound games involving chance, strategy, memory, logic and skill: Tic-Tac-Toe, Music Machine, Echo, Blackjack 13, Magic Square and Mindbender.

492 523 599—Uses 6 'AA' cells*. Each 29.99

D Road-Race Game—hand-held electro-mechanical racing game that lets you start engine, select speed, steer around obstacles and other cars, accelerate and brake. Hitting obstacle delays you. Fastest lap time wins. Digital lap timer.

492 523 596—Uses 2 'C' cells*. Each 14.99

E Digital Derby™. Race your car through heavy traffic—but don't crash. Variable speeds. Uses 2 'C' cells*.

492 523 530—Each 19.99

F M.V.P. Pinball. Enjoy the thrills and skills of mini-pinball. Flashing lights and sounds, 6 action bumpers. Digital readout; reset wheel; flippers.

492 523 594—Use 4 'C' cells*. Each 13.99

G Electro-Mechanical Baseball. Big League action in a small package. L.E.D. 'ball' heads towards plate, 'batter' swings—if he connects, L.E.D.'s light up. When play stops, remaining L.E.D. indicates hit or out. Manual scoring.

492 523 595—Uses 2 'AA' cells*. Each 14.99

H Quiz-Wiz™. Challenge-the-computer answer game. Snap computer and game cartridge together and try questions from Quiz Book. Quiz Wiz lets you know if you've answered right or wrong. Includes computer, vinyl carrying case, one game cartridge and quiz book. About 3 x 8 1/4" long.

492 523 564—Uses one 9-v. cell*. Each 28.99

J 1001-Question Cartridges for Quiz Wiz™. From the editors of Encyclopedia Britannica. With bilingual question book.

492 523 603—Understanding Energy. Each 5.49

492 523 604—Ocean—Man's Last Frontier. Each 5.49

492 523 605—How Things Work. Each 5.49

K 1001-Question Cartridges for Quiz Wiz™. Complete with bilingual question book.

492 523 572—Math Mania. Each 5.49

492 523 573—Movies and TV. Each 5.49

492 523 575—Trivia. Each 5.49

L Zodiac Astrology Computer—provides the same type of information you would receive from astrologer: complete horoscopes; updates information for any day you wish; advice on life's questions. Electronic lights and sounds.

492 523 628—Uses two 9-v. cells*. Each 49.99

M Electronic Quarterback™. Computer controls defence—you control offence. Choose pass, kick or run options. 2 skill levels. L.E.D. displays; built-in sound effects.

492 523 542—Uses one 9-v. cell*. Each 29.99

N Battery Eliminator—AC adapter for electronic games, toys and products which require one 9-volt battery.

492 523 650—Plugs into any AC outlet. Each 7.99

P Head-to-Head™ Electronic Football—play against computer or opponent. Control defence or offence—pass, kick, run and block. L.E.D. statistical displays, electronic sounds.

492 523 629—2 skill levels. Uses one 9-v. cell*. Each 39.99

R Head-to-Head™ Electronic Hockey—compete against computer or another player. Control defence or offence. Pass, block, shoot and rebound features. L.E.D. statistical display. Exciting electronic sounds. 2 skill levels. Uses one 9-v. cell*.

492 523 630—Each 39.99

T Head-to-Head™ Electronic Basketball—challenge the computer or another opponent! Offence and defence controls. Pass, block, aim, shoot and rebound features. L.E.D. statistical display. Electronic sounds. 2 skill levels.

492 523 631—Uses one 9-volt cell*. Each 39.99

U 'Stop Thief' electronic board game. Capture the invisible thief by following audible clues given by computer.

492 523 598—Ages 8 and up. Uses one 9-v. cell*. Each 29.99

W Intercept™. Electronic search and destroy game—intercept attack jet and save the airfield. Built-in sound effects.

492 523 535—Ages 8 and up. Uses one 9-v. cell*. Each 27.99

X Electronic Battleship. Play hide-and-seek on the high seas. Object is to sink your opponent's ships. Hits are indicated by flash of light. Realistic explosion sounds.

492 523 635—Ages 8 and up. Uses two 9-v. cells*. Ea. . 44.99

*Batteries not incl.—see Page 335. Items requiring one 9-v. battery can be used with 'Battery Eliminator' (Item N).



M Electronic Quarterback 29.99

L Zodiac electronic astrology computer 49.99

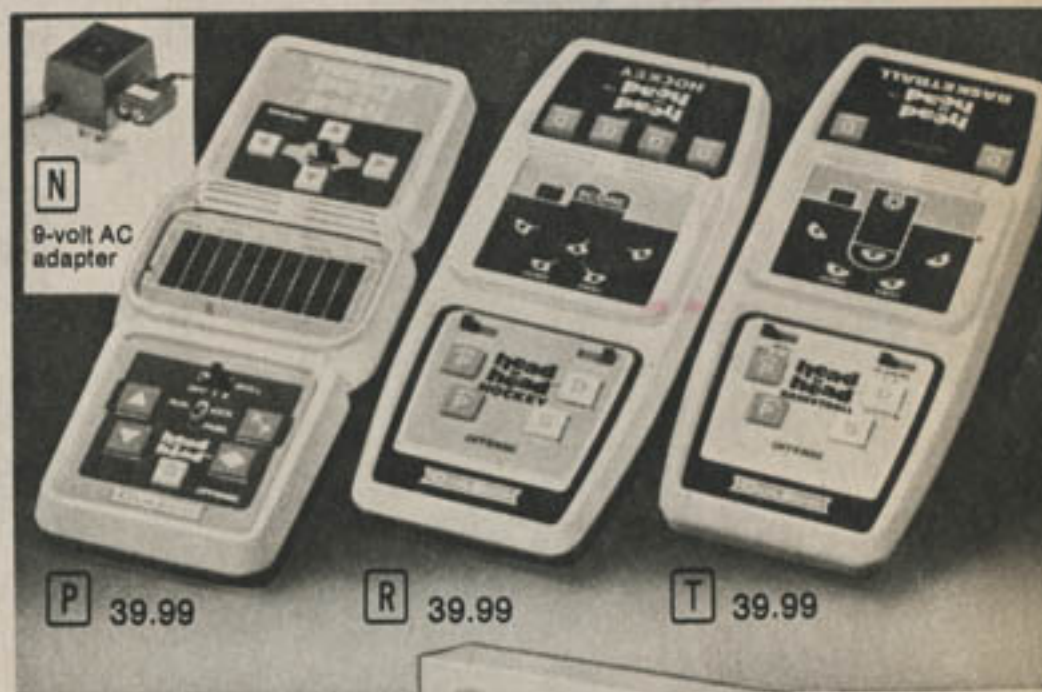

N 9-volt AC adapter

P 39.99

R 39.99

T 39.99

U 'Stop Thief' electronic game 29.99



W Intercept™ 27.99



X Electronic 'Battleship' game 44.99

Fun and games

1 **Roxie & Rick™** set of 2 musical games... gives classic games a new twist. Roxie & Rick, the rock star twins, sing and narrate instructions and clues on the game cassette. **Simon Sings™** includes playmat and prize tokens (approx. time, 21 minutes). **Hide 'n Speak™** includes clue cards, prize tokens (approx. time, 45 minutes). For ages 4 to 6 years.
49 N 64660—Shipping weight 2 lbs. 9 oz. . . Set \$12.99

2 Get ready for lots of outer space action with **Space Turbo™**. High-tech command center brings you all the sights and sounds of a realistic alien attack. Pushbutton joystick control, laser blasts, digital screen. Plastic. Requires 4 "D" batteries, sold separately on p. 404. For ages 4 years and up. Shipping weight 4 pounds. 49 N 65312... \$24.99



Cassette player, not included



3 thru 8 **Sesame Street® Games For Growing™** feature those lovable characters from the TV show. These pre-school card and board games make learning fun, each with a variety of activities and difficulty levels. 1 to 4 players. \$4.99 after rebate from International Games Inc. See details on p. 404. For ages 3 years and up.
(3) 49 N 64615—Alphabet (4) 49 N 64616—Counting
(5) 49 N 64617—Shapes (6) 49 N 64618—Colors
(7) 49 N 64619—Animal Family
(8) 49 N 64620—Going Places
Shipping weight 1 lb. 11 oz. . . Full price, each \$6.99

9 **Checkers™**... a family classic! This quality edition features stackable, solid checkers and heavy-duty game board, coated for long-lasting protection. For ages 6 years to adult.
49 N 61271—Shipping weight 1 lb. 6 oz. . . \$4.99

10 **Chinese Checkers™**... an oriental challenge. Easy to learn—always interesting. Steel playing board and 60 glass marbles. 2 to 6 players. For ages 6 years to adult.
49 N 61273—Shipping weight 1 lb. 7 oz. . . \$4.99

11 **Don't Break the Ice™** Lot's of fun, but watch out. Tap out chunks of ice without dunking the man into the lake. 2 to 4 players. For ages 3 years and up.
49 N 64676—Shipping weight 1 lb. 4 oz. . . \$4.99

12 **Ants in the Pants™** is a pre-school favorite. Whoever gets all their ants in the pants first, wins. 2 to 4 players. For ages 3 years and up.
49 N 64675—Shipping weight 12 oz. . . \$4.99

13 **Catch Cootie™** fever! A children's favorite for more than 2 generations. Players race to finish their cootie. 1 to 4 players. For ages 3 years and up.
49 N 62577—Shipping weight 12 oz. . . \$4.99

14 **Don't Spill the Beans™** is a real balancing act! Players try to get rid of their beans without dropping them. Spill the beans and you take them all. 2 to 4 players. For ages 3 years and up.
49 N 62572—Shipping weight 1 lb. 6 oz. . . \$4.99

15 thru 17 **All-Together™** pre-school games are lots of fun and teach basic learning skills. There are no loose pieces to get lost or swallowed. Plastic. 1 to 4 players. For ages 3 to 5 years.

15 **The Great Snail Race™** teaches counting. 1-2-3!
49 N 64650—Shipping weight 1 lb. 4 oz. . . \$9.99

16 **Shape Chomper™**. Collect a circle, square, star and triangle. Shape Chomper tries to steal them.
49 N 64651—Shipping weight 1 lb. 4 oz. . . \$9.99

17 **Where Are The Animals?™** Match animal pictures and be the first player back to the barn.
49 N 64652—Shipping weight 1 lb. 4 oz. . . \$9.99

*Trademark Children's Television Network



National **Nintendo**[®] Headquarters

It's chock full of surprises...the Nintendo Entertainment System keeps you playing with power throughout all sorts of adventures, challenges and FUN!



© 1986
Nintendo



NES Advantage™ joystick
\$44.99

1



NES Max™ controller
\$24.99

2



3

4



5

1 Talk about power! Want more heavy-duty firepower? How about extra mobility and control for those tight spots? The NES Advantage™ arcade-like joystick offers full action control, and the variable turbo buttons let you pick the rapid-fire capabilities you need for your game. Slow-motion function gives you time to plan your moves on some games. 1 or 2 player selector switch. Plastic. Imported. Warranted by Nintendo*. 49 N 65926—Wt. 2 lbs. 5 oz. . . \$44.99

2 Put power in the palm of your hand . . . The NES Max™ joypad controller lets you cover all areas of the screen easier with a cycloid button that rotates 360 degrees. Turbo buttons let you "power up" for repeat firing. One-of-a-kind design gives you a better grip on the controller for maximum handling. Plastic. Imported. Warranted by Nintendo*. 49 N 65875—Wt. 1 lb. 8 oz. . . \$24.99

3 Save \$5 when you also buy 3 game cartridges (see next two pages) . . . sturdy nylon tote bag carries up to 12 of your favorite cartridges. Zip closure and handle. Wipes clean with a damp cloth. 49 N 64802—Wt. 3 oz. . . Alone \$9.99
When you also buy 3 cartridges . . . \$4.99

4 Protect your cartridges from dirt and dust. Hi-tech roll top case holds up to 20 games. Plastic. Measures 12x12x7 inches high. 49 N 65861—Wt. 4 lbs. . . \$24.99

5 Video storage cart houses your whole system. Attractive rolling cabinet has room for your game system, cartridges and accessories. Sliding front closure. Open back allows easy access for electrical wiring. Hardwood construction. About 16x21x22 in. high. All Nintendo®, Sega® or Atari® video games fit inside cabinet. Unassembled. 49 N 64708C—Wt. 29 lbs. . . \$49.99

\$99.99

The Nintendo Action Set gives you everything you need to start your own system:

- ◆ NES base unit
- ◆ 2 controllers
- ◆ Zapper light gun
- ◆ Super Mario Bros.[®] and Duck Hunt on one game cartridge
- ◆ AC adapter and hookup accessories

6 Challenge your friends and family to thrilling levels of action and excitement! The action set control base is the core of the system; it houses two microchips that provide extremely high-quality graphics and real-life sound. Two controllers have six-foot cords. Zapper light gun receives light through the screen and operates up to 16 feet from TV; it's so accurate that if you're a fraction of an inch off target, you've missed! High-impact plastic body. Base measures 10x8x3¾ inches high. Warranted by Nintendo*. For ages 8 years and up. 49 N 65951—Wt. 7 lbs. 4 oz. . . Set \$99.99

*Write for free copy, see page 304.
*Super Mario Bros. is a registered trademark of Nintendo.

A COMPLETE SELECTION

No more searching from store to store...your favorite games are here. Just see the next two pages

SO CONVENIENT

Our games are ready to go... they can be shipped directly to your home or to your nearest Sears store

SATISFACTION GUARANTEED

or Your Money Back, as with everything Sears sells! If your game cartridge is faulty or you don't want it for any reason, just return it

JUST TURN THE PAGE AND PICK FROM OUR HUGE SELECTION OF GAMES!



© 1986 Nintendo

OFFICIAL
STAR TREK

Communications Console **19⁹⁹**



C **49⁸⁸**

Electronic Phaser Battle Game
Attack under Fire!
Defend your spaceship



F
Phaser Gun
6⁷⁷



B
Star Trek Communicators
19⁹⁹
pair



E
Star Trek Phaser II Game
11⁴⁴



D
U.S.S. Enterprise Control Space Flight Game
11⁹⁹

Star Trek Metal Detector explores environment

Search for Hidden Metal as though you were exploring an alien planet. Fully assembled beat-frequency oscillator clips on belt with ear plug (no speaker) so only you can tell when you're on to something. Use outdoors to find money, jewelry, interesting "junk" under sand or ground, or indoors to locate metal behind walls, etc. Lightweight, easy to operate. With Star Trek insignia. Plastic housing. Aluminum shaft, 30-in. long. Uses one 9-volt battery (not included, order under [F] on facing page.

X 925-0523 A—Mailable: wt. 1.75 lbs. **28.88**

TOYS AREN'T JUST FOR CHRISTMAS.
Save this catalog. Order anything on these two pages—
at these low prices—till August 13, 1977



28⁸⁸

JCPenney 419

New in Sears Land!
"Hey Mom! My new friend Socrates™ is teaching me everything!"



Socrates™, the Educational Video System that doesn't need a VCR. Over 90 built-in programs help teach your child math, spelling, grammar, music and art. TV and VCR are not included. Warranted by Video Technology Industries, write for free copy, see p. 304.

1 Socrates™ main unit. Wireless keyboard is in alphabetical order for easy letter location. Wired cursor controllers pop out of keyboard. Main unit wires directly to TV and requires 6 "D" cell batteries, or AC adapter (item 6), sold separately below. Remote keyboard requires 4 "AA" batteries, sold separately below. Measures 13¹/₂ x 9¹/₂ x 3¹/₄ in. For ages 5 years and up. 49 N 17890—Wt. 3 lbs. 14 oz. . . \$129.99

2 Socrates™ Touch Pad is designed especially for preschoolers. Allows easier answering of questions. Interacts directly with Socrates main unit (sold separately above). Includes preschool cartridge that teaches preschoolers how to form upper and lower case letters, numbers, and shapes. Child can draw with finger or magic pen (included). Also teaches children how to count, match shapes and recognize upper and lower letters. Requires 4 "AA" batteries, sold separately below. Measures 11¹/₂ x 9¹/₂ x 1¹/₄ in. For ages 3 years and up. 49 N 17892—Wt. 2 lbs. 4 oz. . . \$44.99

3 Socrates™ Mouse System is a wireless remote control for the creative artist. Working directly with the main unit (sold separately above), it allows you to draw in fine detail. Incl. CAD Professor cartridge for exploring fashion, architectural and interior design and pattern making. Drawings can be stored and recorded with use of a VCR. Requires 4 "AA" batteries, sold separately below. Measures 11¹/₂ x 9¹/₂ x 1¹/₄ in. For ages 5 years and up. 49 N 17893—Wt. 2 lbs. 4 oz. . . \$44.99

4 Socrates™ Voice Cartridge turns Socrates main unit into an audio/video system. Computer voice talks kids through all activities. Measures 3¹/₂ x 1¹/₂ x 1¹/₂ in. Imported. For ages 5 years and up. 49 N 17894—Wt. 5 oz. . . \$39.99

Your TV can be transformed into a learning system, and you don't need a VCR!

- Large-screen, high-quality graphics will keep them thrilled for hours
- Socrates' "brain" holds over 90 educational games for learning fun



Socrates Touch Pad gives preschoolers an easy way to interact with Socrates



Draw pictures quickly and accurately with the Socrates Mouse System



Socrates Voice Cartridge turns main unit into an audio/video system

DieHard® alkaline batteries

DieHard® 9-volt battery. Pkg. of 1. 9 N 3094—Wt. 2 oz. . . Pkg. \$2.39

DieHard® "AAA" batteries. Pkg. of 2. 9 N 3091—Wt. 1 oz. . . Pkg. \$1.79

DieHard® alkaline batteries. Pkg. of 12.

Battery size	Catalog Number	Wt.	Price, package
"AA"	9 N 30905	10 oz.	\$6.88
"C"	9 N 30925	1 lb. 9 oz.	8.88
"D"	9 N 30938	3 lbs. 7 oz.	8.88

5 When learning's fun, the sky's the limit! Our popular, educational Computron™ does just that! Computron™ helps teach addition, subtraction, multiplication and division. Problems appear on the LED screen as children use the colorful lesson book to follow along. The touch-sensitive keyboard responds quickly to each entry and the correct response wins a musical salute! Children can create their own songs on Computron's™ full musical scale or play the tunes provided in the lesson book. Unit automatically shuts off when left unattended. Requires AC adapter sold separately below, or 6 "C" batteries, sold separately above right. For ages 5 years and up. 49 N 17702—Wt. 3 lbs. . . \$29.99

6 AC power adapter. UL listed. Not recommended for ages under 5. 49 N 17995—Wt. 10 oz. . . \$9.99

25,000 problems and 10 different learning activities mean almost endless fun with our exclusive Computron™

\$29.99

Spend less on batteries with this AC adapter



Put an electronic genius to work



System includes Console, Basic Language Cartridge, Basic Language Instructional Cassette, 322-page programming textbook, operating manual, TV switch box and AC adapter

\$549⁰⁰
(sold on facing page)



Console attaches to any color or black-and-white TV

HARDWARE, SOFTWARE AND ACCESSORIES FOR THE ATARI 400™ PERSONAL COMPUTER SYSTEM

(1) PROGRAM RECORDER

Use with Educational Cassettes (sold at right) or use to record and store your own programs on standard audio tape cassettes. Plays on 2 channels (digital data and audio track). Automatic volume control. 3-digit tape counter. Pushbutton controls.

ELEC. INFO: UL listed; for 110-v. 60-Hz AC.

ORDERING INFORMATION: Only for use with Atari 400™ Personal Computer System.

T3 C 7621C—Shipping weight 4 lbs. \$85.00

(2) PROGRAM CARTRIDGES

Cartridges supplement the computer's power by adding specialized operating instructions.

ORDER INFO: Use up to 4 Joystick Controllers with Basketball and Life Cartridges; 1 Joystick Controller with Music Cartridge; and 4 paddle Controllers with Super Breakout Cartridge (controllers sold at right). Use Education Cartridge with Educational Cassettes (sold at right).

T3C7642—Education. Wt. 6 oz. \$34.99

T3C7645—Basketball. Wt. 6 oz. 49.99

T3C7644—Super Breakout. Wt. 6 oz. ... 49.99

T3C7646—Life. Wt. 6 oz. 49.99

T3C7643—Music Composer. Wt. 6 oz. 69.99

(3) EDUCATIONAL CASSETTES

Traditional educational techniques are used to help teach a subject. While a written text and graphics appear on the screen, a lecturer covers the material. From time to time multiple-choice questions are asked and the user answers by pushing buttons on the console. Each course tape lasts about 3 hours.

ORDERING INFO: Cassettes must be used with Program Recorder and Education Cartridge sold at left. Shipping weight each 10 ounces.

T3 C 7665—Basic Sociology \$39.99

T3 C 7666—Basic Psychology 39.99

T3 C 7662—Spelling 39.99

T3 C 7663—History of Western World ... 39.99

T3 C 7664—Great Classics of Eng. Lit. ... 39.99

T3 C 7667—Principles of Economics 39.99

T3 C 7661—U.S. History 39.99

T3 C 7668—Principles of Accounting ... 39.99

T3 C 7669—Business Communications.. 39.99

(4) JOYSTICK CONTROLLERS. For use with Basketball, Life and Music Cartridges. Pkg. of 2.

T3 C 7687—Wt. pkg. 1 lb. 1 oz. Pkg. \$19.99

(5) PADDLE CONTROLLER. For use with Super Breakout Cartridge. Pkg. of 2.

T3 C 7688—Wt. pkg. 10 oz. Pkg. \$19.99



Our lowest prices ever for these 25-inch ^{diagonal measure picture} Console



- Sensor-Touch with electronic tuner lets you change channels instantly and silently at the touch of a finger, without flipping through intervening or unused channels. Select any of 12 VHF or UHF channels you preset. No moving parts to slip or wear out for years of dependable service
- Super Chromix® black matrix picture tube with fully illuminated color phosphors surrounded by black for a sharp picture and vivid color
- Adjustable one-button color with AFC locks in best picture and color. Controls for color, tint, contrast and brightness let you "adjust" picture to taste

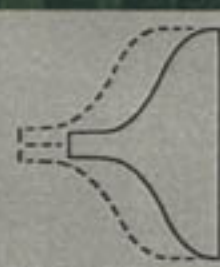

- In-line picture tube provides sharp detail, yet it's not as deep as our standard picture tubes . . . lets you move set closer to the wall and out of the way
- Remote control lets you change channels in either direction without going around the complete cycle, adjust volume and turn set on or off from anywhere in the room



\$699⁹⁵
each

(1 thru 3) These Consoles let you sit back and relax while the wireless remote control turns set on or off, changes channels and adjusts volume for you. In-line picture tube and light sensor provide sharp, clear picture in varying light conditions

Priced \$150 less than in our 1979 Spring Big Book, page 1029
Includes features described at top of this and opposite page, plus 3-function wireless remote control (incl. 2 AA batteries). In-line picture tube. Light sensor automatically adj. brightness, color, contrast to room light conditions.

Tone control lets you tailor sound to your personal taste. Two 4x6-inch speakers. Hidden casters. Draws 185 watts AC.
ORDERING INFORMATION: See full one-year warranty on opposite page. 1979 Spring Big Book price \$849.95 each.

(1) Colonial-style

The Monticello. Colonial-style cabinet with dark maple-veneered top. Gallery, sides and front of simulated wood with matching maple finish. Measures 42¹¹/₁₆x31¹⁵/₁₆x21¹⁷/₃₂ inches deep. 57 C 44671N—Shpg. wt. 181 lbs. \$699.95

(2) Mediterranean-style

The Santiago. Mediterranean-style cabinet with light pecan-veneered top. Sides and front of simulated wood with matching pecan finish. Measures 42x29⁵/₁₆x21³/₁₆ inches deep. 57 C 44681N—Shpg. wt. 179 lbs. \$699.95

(3) Contemporary-style

The Brookings. Contemporary-style cabinet with walnut-veneered top. Sides and front of simulated wood with matching walnut finish. Measures 42³/₁₆x28⁹/₁₆x21³/₁₆ inches deep. 57 C 44661N—Shpg. wt. 181 lbs. \$699.95

This Pocket Computer from Sharp is part of a system you can carry in your briefcase



Slimmer than slim... computer alone slips easily into your pocket



Computer and Printer/Cassette Unit comes in a neat attractive suede-look case



Student Computer Kit also includes a tutorial handbook, quick reference guide and a vinyl wallet case

Printer/ Microcassette Unit

2



Student Computer Kit

(1) Sharp PC-1250 A Student Computer Kit. Perfect for high school, college or even business. 2K memory and built-in Extended BASIC programming language. Full range of math functions. Memory Safeguard™ feature prevents erasure of programs even when unit is off. 18 special keys for quick program recall. 24-digit 5x7 dot matrix display for clear reading. Typewriter-like key arrangement and 10 large numerical keys. 2 lithium batteries (included). Warranted by Sharp Electronics, Inc. Write for free copy, see p. 323.
3 E 23060C—Shipping weight 14 oz. Kit **\$89.99**

(2) Sharp CE-125 Printer/Microcassette Unit. Turns Student Computer Kit (1) into a book-size computer work station offering program and data storage on standard microcassettes and a thermal printer in one. 2-way power source operates on rechargeable Ni-Cad battery (incl.) when on the go, or on AC (adapter incl.). Also instruction manual, 20 math orientated programs on a microcassette tape, 3 rolls paper, 2 blank cassettes and carrying case. Warranted by Sharp Electronics, Inc. Write for free copy, see page 323.
3 E 23061C—Shipping weight 1 lb. 7 oz. ... **\$149.99**

Save \$10.00 when you buy (1) and (2) together. Separate prices total \$239.98.
3 E 23062C—Shipping weight 2 lbs. 5 oz. ... **\$229.98**

Plug-in Software Modules. Up to 16K memory. Intermediate Mathematics. Math algorithms for calculating prime factors, gamma/hyperbolic functions, optimization, matrices, cubic spline interpolation.
3 E 23063—Shipping weight 1 lb. **\$19.99**

General Statistics. Offers a random number generator. Computes means and moments, t-tests, anova, contingency table and rank-sum tests.
3 E 23064—Shipping weight 1 lb. **\$19.99**

Electrical Engineering. Transistor parameter conversion, fourier analysis, Bode/Nyquist calculations, reactance charts, coordinate transformation.
Shipping weight 1 pound.
3 E 23065 **\$19.99**

Business Finance. Annuities, rent/buy decisions, cash flow, flow analysis, bond/machinery analysis, depreciation. Shipping weight 1 pound.
3 E 23066 **\$19.99**

Printer Paper. Package of 5 rolls.
3 E 23067—Shipping weight 2 lbs. Pkg. **\$1.99**

Organize your Home Computer System in style

(3 thru 5) These desk units are especially designed for the Personal/Home Computer user. Each has a medium oak woodgrain finish. Shipped unassembled.

(3) Slide-top Computer Desk. Work surface is at a comfortable typing height to help reduce user fatigue. Generous work surface area is 24 inches deep x 48 inches wide. Slide-top work surface moves back (without disturbing items on top) to reveal two rows of letter size files for storage of floppy or hard discs, manuals or paperwork. Without file racks in place, bin can be used for storage of cartridges, manuals, etc. Ample pencil drawer located beneath built-in video monitor stand. Full length modesty panel. Cord access thru back of desk.
3 E 61222N—Shipping weight 92 pounds **\$139.99**

(4) Mobile Storage/Shelf Unit. Designed for use with (3) Desk above, providing added storage. Solid color top for contrast, usable as work surface when unit is not under desk. Doors lift up, push back to reveal general storage compartments for hardware, software, paperwork. Larger storage area below has adjustable shelf. Casters allow mobility. Appears as a "pedestal" when stored under computer desk.
3 E 61224L—Shipping weight 42 pounds **\$89.99**

(5) Mobile Storage/File Unit. Designed for use with (3) Desk above. Solid color top provides added work surface space when closed. Flip open top to reveal storage bin which provides file hangers for computer printouts in binders, or for letter size files. Pull up, push back door covers general storage compartment below. Casters allow mobility. Appears as a "pedestal" when stored under computer desk.
3 E 61223C—Shipping weight 38 pounds **\$89.99**



\$5 less thru December 15th



IT'S FUN! IT'S CHALLENGING!
THE NEW TALKING COMPUTRON™
PROMOTES MORE LEARNING SKILLS THAN ANY OTHER
ELECTRONIC EDUCATIONAL TOY WE'VE EVER SEEN . . .
ACCEPTS ADD-ON SOFTWARE FOR EVEN MORE EXCITING PLAY

- Develops math skills
- Expands powers of logic
- Helps teach the alphabet
- Assists pronunciation
- Improves spelling
- Creates musical awareness

With almost twice the child-pleasing activities of our original Computron™ plus a friendly "computer" voice, the new Talking Computron™ is the learning toy of the year! This chatty playmate boasts 19 fun-filled activities, a delightful 120-word vocabulary for spelling, pronunciation and word games. All math quizzes feature 3 levels of play and 3 musical activities, too. Your child's responses on the smooth, touch-sensitive keyboard quickly register on the unit's LED screen. Order additional word cartridges at right. Uses AC power adapter (6) at right, or 6 "C" batteries, sold separately on p. 404. For ages 5 years and up. 49 E 17727 . . . Shipping weight 3 lbs. Thru 12/15/86: \$37.99 . . . After 12/15/86: \$42.99

2 thru 5 Additional word cartridges for (1) . . . expand Talking Computron's vocabulary by 100 words each for lots of new challenges in 7 language activities. Storybook included.

Item	Title	Catalog No.
(2)	Visit the Zoo	49 E 17865
(3)	Day to Bake	49 E 17867
(4)	Dress-up Theatre	49 E 17869
(5)	Rocket to Zenod	49 E 17871

Shipping weight 7 oz. . . Each \$12.99

6 AC power adapter for (1). Also can be used with the original Computron, sold on page 498. UL listed. Not recommended for ages under 5. 49 N 17995—Shpg. wt. 10 oz. . . \$9.99



Additional word programs include a colorfully illustrated storybook



Convenient AC adapter means you'll never have to worry about batteries again



Price Breakthrough

Never before have we offered hand-held electronic games that are so much fun to play and so difficult to master yet are priced so low

Your choice of Electronic Numbers Game or Follow Me

Each \$14.99 without battery or adapter only

These aren't the first or the only hand-held computer games that challenge your memory and powers of deduction. There are others on the market that play virtually the same way as our Follow Me and Electronic Numbers Game. What makes these so special is our \$14.99 price. Compare this price, compare the features and we're sure you'll agree that these are exceptional values.

Electronic Numbers Game

Here's the computer game that challenges you to break a secret code while the computer gives you the clues and keeps score.



IT'S ENTERTAINING AND EDUCATIONAL

Set secret 4-digit code for another player to solve or let the computer set one for you. Then begin testing numbers in different sequences. After each try the computer tells which are correct and in the right sequence until code has been broken.

WHO'S THE MASTERMIND IN YOUR FAMILY?

Play the Numbers Game by yourself. Or you can double the fun playing against someone else. In this version you're not only testing your code-breaking skills but also your ability to develop codes that are difficult to solve. You can even play with a group. Plastic case measures 5½ by 3½ by 1 in. high. Includes vinyl carry case, scorepad.

FOR AGES: 8 years to adult.

ORD. INFO: Instr. incl. Needs 1 alkaline 9-v. batt. or AC Adapter, not incl. Order battery on p. 666.

LAST DATE TO ORDER THIS ITEM IS JAN. 31, 1980.
49 C 65437—Shpg. wt. 8 oz.\$14.99



Electronic Follow Me

Probably no other type of hand-held electronic game is so easy to play yet so difficult to master. And that's why this game has become so popular with children and adults of all ages.

MATCH YOUR MEMORY AGAINST THE COMPUTER

Follow Me will play a random sequence of lights and sounds. All you have to do is repeat them by pressing the correct "Follow Me" buttons. Sound easy? Well it is for the first few series. But then each sequence becomes progressively longer and faster, too. If your memory is good enough you're rewarded with a victory tune—but if it isn't, Follow Me will signal loud and clear that you made a mistake.

THERE ARE 3 GAME VARIATIONS AND FOUR SKILL LEVELS

You can let the computer program the sequence of sounds and lights. Or you can set up the sequence for your opponent to follow. The computer remembers what has been the longest sequence followed correctly and will replay it at just a touch of a button. It will also recall the last sequence played whenever you wish. Even a group can have fun with Follow Me. In this version each player has a different color and remains in the game as long as he or she plays that color at the proper times. Make a mistake and you and your color are out of the game. The different skill levels make the game more challenging by playing longer and longer sequences to follow.

Follow Me is housed in a plastic case that's 5 inches in diameter, 2 inches high.

FOR AGES: 6 years to adult.

ORDER INFO FOR FOLLOW ME: Instr. incl. Requires one alkaline 9-v. battery or AC Adapter, not incl. Order battery on p. 666.

LAST DATE TO ORDER THIS ITEM IS JAN. 31, 1980
49 C 65439—Shpg. wt. 8 oz.\$14.99



Universal AC Adapter

(Not shown.) UL listed to convert 110-120-v. 60-c. AC to 6, 7½ or 9-volt for use with games indicated or other battery-powered items of low voltage with adapter receptacles. Miniature and sub-miniature adjustable plugs, 9-volt battery clip tip included, 6-foot cord. Not recommended for children under 8.

49 C 65244—Shpg. wt. 6 oz.\$4.99

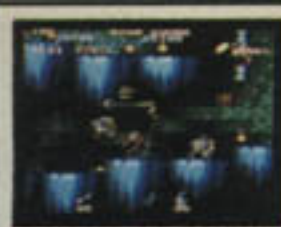

Black Tiger™
49 N 65897 ... \$39.99



Blades of Steel hockey
49 N 65989 ... \$49.99



Break Thru™
49 N 65671 ... \$34.99



Burgertime®
49 N 65506 ... \$29.99



City Connection™
49 N 65975 ... \$29.99



Cobra Command™
49 N 65891 ... \$44.99



Freedom Force™
(Zapper gun)
49 N 65955 ... \$37.99



SORRY, NOT AVAILABLE

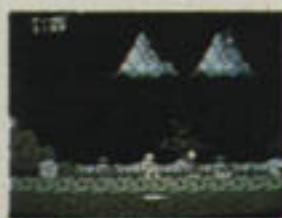

Ghosts 'N Goblins™
49 N 64783 ... \$29.99



Go!
49 N 65861 ... \$29.99



©1986 Nintendo



Jackal
49 N 65893 ... \$34.99



Jaws™
49 N 64797 ... \$39.99



©1987 Nintendo

LOOK ANYWHERE ELSE! video games anywhere in the USA!

When you want the hottest new games, look to Sears. New shipments are arriving weekly, ready for delivery!

Cartridges Gotcha!™, Hogan's Alley® and Freedom Force™ require Zapper gun sold with the Action Set on page 441. Wt. each game 8 oz. Imported. Warranted by Nintendo; write for free copy, see page 304.

with power!



Karnov™
49 N 65681 ... \$34.99



Kid Icarus™
49 N 65959 ... \$39.99



Legendary Wings™
49 N 64796 ... \$34.99



Legend of Zelda™
49 N 65919 ... \$39.99



Pac Man®
49 N 65502 ... \$37.99



Platoon™
49 N 65883 ... \$39.99



Pro-Am Racing™
49 N 65955 ... \$39.99



Pro Wrestling
49 N 65923 ... \$34.99



Racket Attack tennis™
49 N 65993 ... \$44.99



Rad Racer™
(w/ 3-D glasses)
49 N 64789 ... \$34.99



Simon's Quest
49 N 65982 ... \$44.99



Skate or Die®
49 N 64788 ... \$39.99



Spy Hunter™
49 N 65841 ... \$34.99

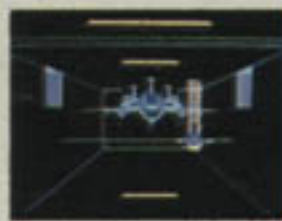

Star Voyager™
49 N 65953 ... \$29.99



Superman™
49 N 65514 ... \$39.99



Super Mario Bros. II®
49 N 65957 ... \$44.99



Trojan™
49 N 65895 ... \$29.99



Wheel of Fortune™
49 N 64794 ... \$39.99



Winter Games™
49 N 65956 ... \$34.99



Wizards and Warriors™
49 N 65962 ... \$34.99



Xenophobe™
49 N 65881 ... \$37.99



SORRY, NOT AVAILABLE

Bring the world of video into your home and save \$300 on the entire page

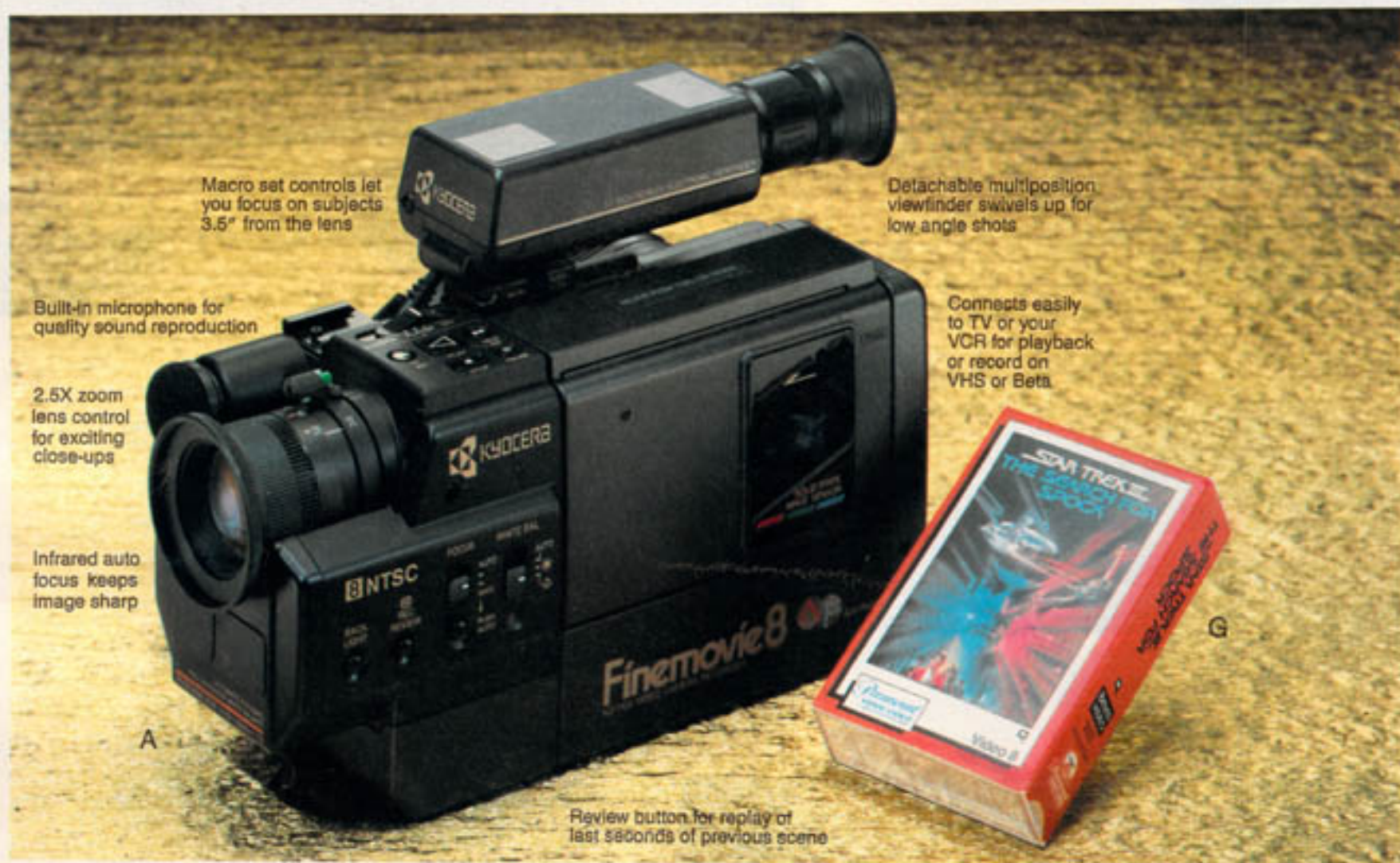

Macro set controls let you focus on subjects 3.5" from the lens

Detachable multi-position viewfinder swivels up for low angle shots

Built-in microphone for quality sound reproduction

Connects easily to TV or your VCR for playback or record on VHS or Beta

2.5X zoom lens control for exciting close-ups

Infrared auto focus keeps image sharp

Review button for replay of last seconds of previous scene



Buy items A-G and you'll save 300.94 from the separate cost of 2188.94!

572 530 856 DL—Ensemble, ea. . . . 1888.00

A Kyocera 8mm Camcorder has a 1-year warranty on parts and labor. Includes camera, 1-hour battery pack, battery charger, AC pack, RF converter and cables for TV hook-up, one 15-minute video cassette and carry strap.

572 530 850 DL—Each 1699.00

B Lightweight Custom Case of strong weather-resistant Cordura®.

572 530 855—Each 149.99

C 8mm Blank Video Cassette for up to 2 hours of recording time.

572 530 851—Each 19.99

1888⁰⁰ Items A-G

D 8mm Head Cleaning Cassette.
572 530 853—Each 29.99

E Extra Battery Pack for up to 1 hour of play/record time.
572 530 852—Each 79.99

F 1.4 Power Tele-Lens Adapter. Increases zoom to 3.5X.
572 530 854—Each 149.99

G 8mm Pre-Recorded Tape of Star Trek III: The Search For Spock. 105 min.
572 530 860—English only. Each . . . 59.99



KYOCERA...moments can last a lifetime

Hand-held electronic entertainment that goes almost



You've got to be quick or you'll get tackled!

YOUR CHOICE
(1 thru 6)
\$9.99



Get your swing down and hit a grand slam!

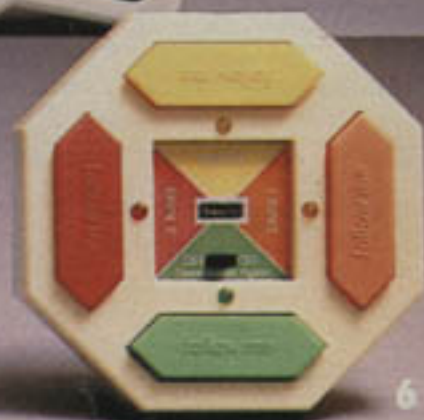

(7 and 8)
\$14.99



Put yourself in the driver's seat



You're the pilot after enemy planes

(9 and 10)
\$17.99



Race against time with Super Sound!



Hear the battle as you attack the enemy!

1 thru 6 Different fun-filled challenges, that's what you're sure to find when you try our exciting electronic games. Each has various skill levels so the game improves as you do. (1 thru 5) require 2 "AA" batteries and (6) requires one 9-volt battery, all sold on page 406. Imported. Ages 5 years and up.

1 Do you want to pass or run the ball? Football game has realistic and animated LCD display that scrolls downfield with the action. Includes sound on/off and skill-level buttons. 4-directional control action key. For 1 or 2 players. 49 N 65461—Wt. 6 oz . . . **\$9.99**

2 Watch for that slow, fast or curve ball as the computer pitches to you. Animated LCD display shows hits, bases, runs, innings and outs. Sound on/off and skill-level buttons. Push buttons for batting and pitching. For 1 or 2 players. 49 N 64040—Wt. 6 oz . . . **\$9.99**

3 Position yourself on the alley and let it go! Exciting bowling-game computer shows strikes, spares, splits and scores and frames on the LCD display. On/off buttons. Multi-directional key controls. For 1 or 2 players. 49 N 65475—Wt. 6 oz . . . **\$9.99**

4 Ready, aim, fire! You've got to be fast and accurate to hit the moving clay pigeons. Play 3 different trapshooting games as you control the gun's angle and position with the rotational knob. High score is retained until it is beat. Sound on/off control. LCD display. For 1 or 2 players. 49 N 65469—Wt. 8 oz . . . **\$9.99**

5 A pinball game that's small enough to hold. Flipper controls send the "ball" bouncing off of 9 different bumpers. You get 5 balls per game with a chance to win a bonus ball if you're good enough! LCD display. Sound on/off control. For 1 or 2 players. 49 N 65465—Wt. 8 oz . . . **\$9.99**

6 "Follow Me" gives your memory a workout! Try to repeat the same combination of flashing lights and sounds as the computer plays . . . but pay attention because each turn produces longer and faster sequences. On/off control. For 1 to 4 players. 49 N 65439—Wt. 8 oz . . . **\$9.99**

7 Test your racing skills as you tear down a 2-lane course. You control the steering and braking. Screen lights up if you crash. Digital lap and crash counters included. Requires 2 "AA" batteries sold on p. 406. Imported. For ages 4 years and up. 49 N 65001—Wt. 14 oz . . . **\$14.99**

8 Time to make a real lift off! As the pilot, you must hit airborne planes; screen lights up red to confirm hits. Includes powerful launch sounds and digital hit and miss counters. Requires 2 "AA" batteries sold on p. 406. Imported. Ages 4 years and up. 49 N 65007—Wt. 1 lb. 2 oz . . . **\$14.99**

9 It's a grueling race against time with Super Sound Road Race game. Features exciting action on a super-sized LCD display. Shows color start lights, speedometer and fuel gauge that monitor the action while you speed up, brake and steer clear of other cars. Watch your fuel gauge . . . you may need to make a pit stop. Multiple skill levels increase automatically. Automatic shutoff. 4-directional control action. Requires 2 "AA" batteries sold on p. 406. Imported. 1 or 2 players, ages 5 years and up. 49 N 65482—Wt. 9 oz . . . **\$17.99**

10 Seek out enemy subs on a super-sized LCD display with Super Sound Sub Wars. Shows color search screen that lets you use "sonar" to locate the enemy. Fires "torpedoes" and offers 9 automatic levels of difficulty. Automatic shutoff. 4-directional control action. Requires 2 "AA" batteries sold on p. 406. Imported. For 1 or 2 players, ages 5 years and up. 49 N 65484—Wt. 8 oz . . . **\$17.99**



Hip-pocket
Alien Invader
\$13.99

A whole fleet of aliens are advancing, trying to land on your planet. Blast them before they destroy your 3 base ships. Plastic housing is 9½x6½ in. Imported. Requires 1 "C" battery, not included, sold on page 595. Warranted by Entex; to write for free copy, see page 323. For ages 8 years and up.
49 C 65002—Shipping weight 1 lb. 4 oz. **\$13.99**

**WISH BOOK
VALUE**

Follow Me
Cut **\$2.50**

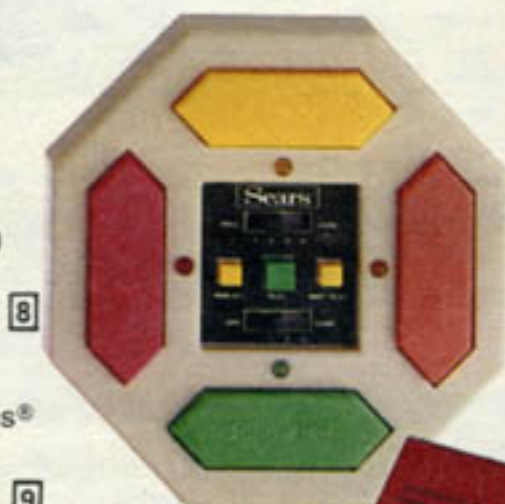

Dungeons & Dragons®
Fantasy Game
Cut **\$5**



Merlin
Save a total of **\$15**
Cut \$10 plus a \$5
rebate from Parker Bros.

(8) Repeat Follow Me's light and sound sequence. With each turn it's longer and faster. 4 skill levels, up to 4 players. 5-in. diameter plastic housing. Uses one 9-volt battery sold on p. 595. See warranty on p. 601. Reduced from 1982 Wish Book, p. 635. For ages 6 years and up.
49 C 65439—Shipping weight 9 ounces . . . Was \$12.49. Now **\$9.99**

(9) Dungeons & Dragons® Fantasy Game in a hand-held computer. Search thru mazes for arrow to slay dragon. Plastic housing is only 3½x2 in. Batteries included. Warranted by Mattel Electronics, see page 323. Reduced from our 1982 Wish Book, page 633. For ages 10 years and up.
49 C 65256—Shipping weight 4 oz. Was \$26.99; Now **\$21.99**

(10) Merlin's memory instantly counters your moves. Six games, variable skill levels. 1 or more players. Requires 6 "AA" batteries, not included, sold on page 595. Warranted by Parker Bros., see page 323. Was \$29.99 in our 1982 Wish Book, page 635. \$14.99 after Parker Bros. rebate . . . see page 545. For ages 7 years and up.
49 C 61061—Shpg. wt. 14 oz. Full Price **\$19.99**

your choice
only **\$9.99**



Exciting Games for little players

(11) Rocket Launch lets you pilot a rocket to destroy elusive airborne planes. Make contact . . . screen lights up red. Digital hit and miss counters. Powerful launch sounds. 1 player. Plastic, 7½x6-in. housing. Imported. Requires 2 "AA" batteries, not included, sold on page 595.
For ages 3 years and up.
49 C 65007—Wt. 14 oz. **\$9.99**

(12) Driving Game lets you control your car on the 2-lane race course. Screen lights up when you crash. Screen lights up when you crash. Digital lap and crash counters. Revved-up engine sounds. 1 player. Plastic, 6½x5½-inch housing. Imported. Requires 2 "AA" batteries, not included, sold on page 595.
For ages 3 years and up.
49 C 65001—Wt. 14 oz. **\$9.99**

There's more for your life at
Sears



SONY.

C

D

Panasonic

169.99 No money down
\$15 a month*

Sony Watchman 2-in. pocket-size TV

C Fits in your pocket! Only 1 1/2 in. thick so you can carry it anywhere! 2-in. recessed/tilted screen for easy viewing—prevents glare. Crystal-clear high contrast black and white 2-inch diagonal screen. Full 82-channel VHF/UHF reception. Input speaker for optional headphones. Built-in video input for use as a monitor with VCRs.

5-way power capability—4 "AA" batteries (included), 4 "C" batteries with optional battery case, rechargeable battery pack, AC current with AC adapter or in your vehicle with car battery cord (all not included, order batteries on page 490).

Convenient flip-out stand. Carrying case and strap. Telescopic antenna for fine VHF and UHF reception. Silver/gray hi-impact plastic cabinet is about 6 3/4 in. high x 3 in. wide x 1 1/2 inches deep. UL listed. Made in Japan. Shown with simulated reception. Write for free copy of Manufacturer's Warranty, see page 497.

63 G 50204 MS—Ship. wt. 1 lb. 8 oz. 169.99

149.99

Panasonic 1 1/2-inch ultra-compact TV

D Panasonic's Travelvision fits in your hand! Features 360-degree electronic tuning system for accuracy. Tuner rotates endlessly, eliminating the need to turn back through unwanted channels. Receives all 82 VHF and UHF channels. Quick-On picture tube for instant picture and sound as soon as you turn the TV on!

4-way operation—use regular AC current, car adapter cord, NI-CD rechargeable battery pack (all included) or built-in battery charger. Snap-down incline stand. Detachable hood screen with magnifying lens. Wrist strap. Earphone and jack. VHF/UHF antenna. Black/silver hi-impact plastic cabinet is about 1 1/2 in. high x 3 1/2 in. wide x 6 inches deep. UL listed. Made in Japan. Shown with simulated reception. Write for free copy of Manufacturer's Warranty, see page 497.

63 G 30155 MS—Ship. wt. 13 oz. 149.99



E

299.99 No money down
\$17 a month*

RCA 19-inch ColorTrak TV

E Enjoy RCA's 3-way automatic color system which automatically adjusts color, brightness and contrast to constantly assure a beautiful lifelike picture. Super AccuFilter picture tube provides super contrast for sharp detail. 2-knob tuning for all 82 VHF and UHF channels.

Unitized XtendedLife chassis is 100% solid-state for excellent performance and low power consumption. BlackLock contrast circuit helps eliminate distortion. Built-in antennas. Walnut wood-grain hi-impact plastic cabinet is about 18 in. high x 26 in. wide x 20 inches deep. 19-inch diagonal screen. UL listed. Made in U.S.A. Shown with simulated reception. Write for free copy of Manufacturer's Warranty, see pg. 497.

63 G 41905 R—Ship. wt. 58 lbs. . . . 299.99 ALL • 569

Game Cartridges for

COLECOVISION

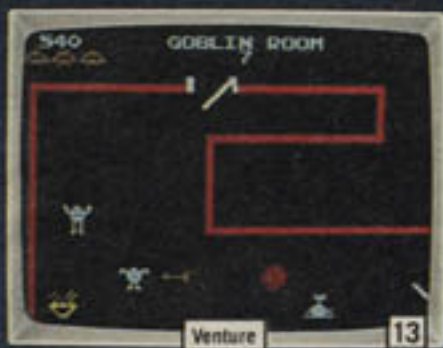

Venture 13



Space Fury 14



New Q*bert 15



Donkey Kong Jr. 16



Mouse Trap 17



New Omega Race 18



Pepper II 19



Lady Bug 20



Space Panic 21



Zaxxon 22

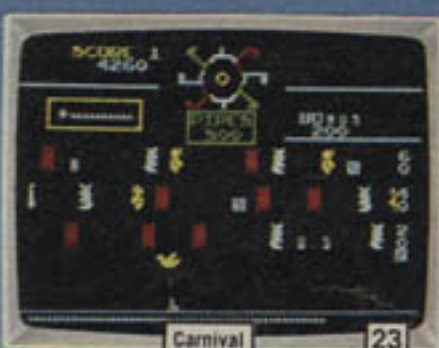

Carnival 23



Cosmic Avenger 24



Smurf Action 25

(13 thru 25) Q*bert and Omega Race are both exciting new at Sears games. All cartridges are warranted by Coleco except Q*bert is warranted by Parker Bros., to write for free copy see page 323. Shpg. wt. 6 oz. each.

Cartridge name and description	Catalog Number	Price
(13) Venture. The more you venture into the treasure-filled dungeon, the more you gain. But it could cost you your life. 1 or 2 players.	49 C 75812	\$34.99
(14) Space Fury. Meet your enemy face to face. Then destroy his furious forces. Dock with your mother ship for refueling and more ammunition. 1 or 2 players.	49 C 75811	34.99
(15) Q*bert. Bouncing from cube to cube, avoid the cast of loony characters out to drive you mad. 1 or 2 players.	49 C 75701	39.99
(16) Donkey Kong Jr. Perform 4 new feats to save Papa Donkey Kong from angry Mario. 1 or 2 players.	49 C 75833	34.99
(17) Mouse Trap. Watch for hungry cats as you scurry thru mazes eating cheese for points. 1 or 2 players.	49 C 75813	34.99
(18) Omega Race for Roller Controller. Maneuver thru space to battle fleets of enemy androids. 1 or 2 players.	49 C 75845	34.99

Cartridge name and description	Catalog Number	Price
(19) Pepper II. Go maze-crazy zipping rooms shut only to have them re-opened by the zipper ripper. 1 or 2 players.	49 C 75835	\$34.99
(20) Lady Bug. Help hungry lady bug thru maze of edible dots, dodging insidious insects. It could drive you buggy. 1 or 2 players.	49 C 75814	34.99
(21) Space Panic. In a super space structure, dig pits to ditch aliens before oxygen runs out. 1 or 2 players.	49 C 75821	34.99
(22) Zaxxon. Fast-paced 3-D game, you destroy enemy installations but avoid their defenses to face deadly Zaxxon robot. 1 or 2 players.	49 C 75816	49.99
(23) Carnival. Sure-fire fun. An old-fashioned shooting gallery with rabbits, bears and ducks that swoop down to eat your ammo. Are you game? 1 or 2 players.	49 C 75820	34.99
(24) Cosmic Avenger. Destroy ever-changing enemy installations while avoiding their relentless return fire. 1 or 2 players.	49 C 75815	34.99
(25) Smurf Action. Rescue distressed Smurfette from castle. 1 or 2 players.	49 C 75819	34.99

For even more ColecoVision accessories, just turn the page



Save \$20. Now that you've got your VCR and TV, where are you going to put them? How about a good-looking hickory-grained vinyl stand that holds both your TV and VCR? It rolls easily to any room and has two wicker-look doors that reverse to match stand's finish. Holds 19-in. TV's (or compact stereos) up to 26 $\frac{1}{2}$ in. wide. 28Hx29 $\frac{1}{2}$ Wx15 $\frac{1}{2}$ D in. See "N" note, p. 323. Was \$89.99 in '83 Fall Big Bk., p. 841. 57E45301L—Wt. 38 lbs. \$69.99



Put your holiday memories on tape, either Beta (L) or VHS (T)

Tape	Hours min/max	Catalog Number	Wt. oz.	Price each
L-500	2/3	57E5350	8	\$ 8.99
L-750	3/4.5	57E5375	8	11.99
L-830	3.3/5	57E5383	9	13.99
T-120	2/4/6	57E82861	14	10.99
T-160	2.3/5 7/8	57E82401	14	19.99



(A) Video Tape Storage Case. Sturdy plastic base holds 12 Beta or VHS tapes. Removable see-through cover. 5 $\frac{1}{2}$ Hx16Wx9D in. 57 E 5630—Wt. 4 lbs. 4 oz. ... \$9.99

Beta/VHS Tape Case for 14 tapes. Dustcover. Plastic. 6 $\frac{1}{4}$ Hx10 $\frac{1}{2}$ Wx19 $\frac{1}{4}$ D in. 57E5603—Wt. 6 lbs. 10 oz. . \$19.99

(B) Attache TV Camera Case is now $\frac{1}{2}$ Price. Securely holds your camera in soft, urethane foam and protects it with a rugged plastic shell. Lockable. 14 $\frac{1}{4}$ Hx18 $\frac{1}{2}$ Wx6 $\frac{1}{2}$ D in. standing up. Was \$69.99 in '83 Fall Big Bk., p. 858. 57 E 5393—Shpg. wt. 6 lbs. \$34.99

(C) Storage Case for 20 audio or 10 video tapes; or 20 video games. Plastic. 6Hx9 $\frac{1}{2}$ Wx16D inches. 57 E 56032—Wt. 5 lbs. 4 oz. \$19.99



Beta format VCR with 3-day/1-program capability, BetaScan plus up to 5 hours of recording time
\$379⁹⁵

NEVER PRICED LOWER

(4) Going away for the weekend and you'll have to miss your favorite show? Not any more. Just preset this VCR to start when your show begins and to stop when it's over and you won't have to miss a minute of any show up to 5 hours long. You can do this up to 3 days in advance. Enjoy pre-recorded movies anytime or make your own with optional camera. Any way you use it, finding your favorite segment is easy with forward and reverse BetaScan. Did that halfback really step out of bounds? ... freeze the action with stop motion and see for yourself. And if you're busy but enjoy daytime drama, set this VCR to come on the same time everyday. Electronic tuner. You also get a clock, instructions and TV hook-up hardware. 5.4Hx17.6Wx13D in. See Note, p. 406. Reduced from our 1983 Spring Big Book, p. 694. Wt. 22 lbs. 57 E 5309N—Was \$489.95; \$379.95

COMPARE!

VHS VCR has 1-day/1-program capability with up to 8 hours of recording plus pause/still remote control
\$439⁹⁹

(5) Of course you can pre-program this VCR up to 24 hours in advance to start recording at the beginning of your show, and to shut off up to 8 hours later. But what's really nice about this VCR is that you can freeze the action to further inspect that touchdown as well as edit while recording without getting up from your chair. The remote control lets you do this up to 20 feet away. You can also watch great pre-recorded movies or make your own with optional camera. To find your favorite segment, just press forward or reverse visual search on the deck. You decide at which speed to watch; Slow Play, Long Play or Extended Play. Electronic tuner. You get a convenient clock plus operating instructions and all necessary hardware for TV hook-up. 5.2Hx17.1Wx13.4D in. See Note, p. 406. 57 E 5307N—Shpg. wt. 23 lbs. ... \$439.99





149.99 when bought with 4 different components
Save \$20-\$50 when you buy Atari 800XL personal computer with different components—the more you buy, the more you save!

A The Atari 800XL personal computer features 64K RAM with user friendly "help" key to provide easier direction on selected programs. Built-in BASIC to handle complex programs. 16K ROM, 4 programmable function keys, 256 brilliant color combinations and 4 individual sound voices covering 3½ octaves. Serial interface easily expands system. Quality full-stroke, full-size typewriter keyboard. You can shift the keyboard into an international character set that lets you communicate in foreign languages. Cartridge slot for easy loading of plug-in programs. Two controller ports for joysticks, paddles or keypad. Connects to any TV or monitor (additional cables/adaptors may be necessary). Compatible with existing Atari peripherals and software. Includes instruction manual, TV switch box and power supply. Manufacturer's style number 800XL.

67 G 21013 LSD—Mfr.'s Warranty,** Ship. wt. 5 lbs. 12 oz. alone 229.99

Save \$20 on computer when bought with one component 179.99
 Save \$30 on computer when bought with 2 different components . . . 169.99
 Save \$40 on computer when bought with 3 different components . . . 159.99
 Save \$50 on computer when bought with 4 different components . . . 149.99

B No money down, \$18 a month.* Atari disk drive stores 127,000 characters or approximately 100 pages of text on one diskette for fast, efficient data storage. Single density. Auto standby. Disk Busy indicator. Includes DOS III Master Diskette, introduction to DOS III booklet and DOS III reference manual. Manufacturer's style number 1050. Manufacturer's Warranty.**

67 G 21113 LSG—Ship. wt. 5 lbs. 349.99

C No money down, \$18 a month.* Atari 80-column letter quality printer. 12 to 20 characters per second speed. Bi-directional. Underlining capability. Includes guide, data cord, AC adaptor. Manufacturer's style number 1027. Manufacturer's Warranty.**

67 G 21133 LSG—Ship. wt. 5 lbs. 4 oz. 349.99

D No money down, \$17 a month.* High-quality Zenith 13-inch color RGB/composite monitor. RGB allows for much higher color resolution than any other form of video input. Screen display of 25 lines by 40 characters. Concealed front panel controls and LED power on indicator. Also sold on page 525. Manufacturer's Warranty.**

67 G 20401 LSG—Ship. wt. 38 lbs. 299.99

E Atari 300 baud telephone modem gives access to other computers over ordinary telephone lines. Plugs directly into user's port and modular phone handset. Manufacturer's style number 1030. Manufacturer's Warranty.**

67 G 21143 LSG—Ship. wt. 4 lbs. 99.99

F Atari program recorder stores and records programs on plain audio cassettes. Stores 100K BYTES per 60 minute cassette. 2 channels—one for computer programs/data, one for sound. Manufacturer's style number 1010. Manufacturer's Warranty.**

67 G 21103 LSG—Ship. wt. 4 lbs. 12 oz. 99.99

See our full line of Atari joysticks and controllers on page 535.

*Montgomery Ward Credit customers: This purchase may change your monthly payments depending on the highest balance on your account. Does not apply to AZ, NM and OR residents. See page 497. **Write for a free copy of Manufacturer's Warranty, see page 497.

Bring 'em back on tape

Photographed at Ramsay House Visitors Center, Alexandria, Va.



1 Save \$100



2 Save \$100



Make your memories come alive . . . forever. Capturing family fun, wedding joy or a baby's smile has never been easier thanks to our featherlight 5½-pound Saticon™ Camera that actually does the focusing for you

(1) Whether you zoom in for a close-up or pull back for a wide shot, crystal clear video is as easy as pointing the camera. Each image is automatically set to a crisp focus as you change shots, so you get great tapes every time. And to catalog your tapes, you can add time, date and titles right on the screen.

You can even use the stop watch to time any event. Low light? This camera is so light sensitive, in most indoor situations, you'll get outstanding ghost-free pictures without floodlights. And you see exactly what the camera sees through the black and white viewfinder. Monitor the sound action picked up by front boom mike with the earphone.

The professional touch. The power to create quality shows is right at your finger tips. Add exciting fades, both in and out, or grab a dramatic close-up with the macro adjustment. And when you use camera with VCR (2), you can start or stop VCR, search forward and reverse, fast forward or rewind.

All of this without letting go of the camera . . . just touch the camera's remote switches.

Your tapes come alive with up to 6 times magnification from this 12.5-75mm F/1.4 zoom lens.

Auto iris, manual override. Adjustable viewfinder. See note, right. 57 E 5388N—Wt. 11 lbs. . . . 1983-84 Camera Book price \$889.99, p. 43. \$789.99

Don't let the size of this VCR fool you

(2) This portable VHS VCR does almost everything the finest tabletop VCR can, yet the deck weighs a mere 7.9 lbs. for comfortable outdoor taping. Use optional camera to create your own shows, saving up to 8 hrs. of memories on 1 tape. Or enjoy controlling what you watch and when from anywhere in the room with 18-button wireless remote. You command channel selection (even on non-remote TV's), record, visual search, play, slow motion, frame-by-frame, TV/VCR switch and more.

When you're out. You'll stop missing shows when you start programming this VCR to start and stop up to 6 times in 14 days. And special effects are really special in extended play mode because they're noise-free on frame-by-frame, slow motion and still. Time on/time off preset.

Add a personal touch to your tapes by dubbing in your voice or music. Deck has handle, shoulder strap. Tuner, deck; each 3.3Hx10Wx10.4D in. Instr., hardware for TV hook-up incl. See Note, right. 1983-84 Camera Book price \$939.99, p. 43. 57 E 5368N—Wt. 16 lbs. . . . \$839.99



3 Save \$100

(3) This affordable Saticon™ Color TV Camera has the same great low light capability as (1), giving you great ghost-free pictures without floodlights. And you still see exactly what the camera sees through black and white viewfinder. Front boom mike picks up sound, and you can monitor it with the earphone.

A real lightweight. It weighs in at only 3.5 pounds yet you'll enjoy great tapes with up to 8 times magnification from the 14-84mm F/1.6 zoom lens. Flick the macro adjustment and you'll get screen-filling close-ups. Then add a professional touch with fade in and out control. Auto iris, manual override. See Note below. 1983-84 Camera Book price \$889.99, p. 43. 57 E 5382N—Shpg. wt. 6 lbs. . . . \$589.99

NOTE: VCR's and cameras are intended for personal use, not any use that might violate copyright laws. See our 1983 Fall Big Book for Sears specific written warranty or write for free copy, p. 323. See "N" note, p. 323. (1) and (3) have 10-ft. cords; use extension (not incl.) up to 66 ft. (2) UL listed. AC.

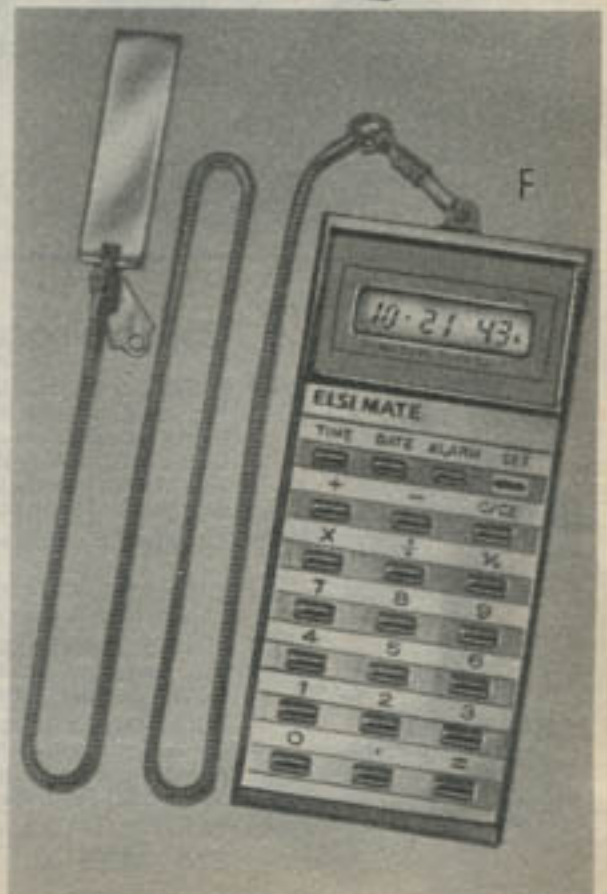
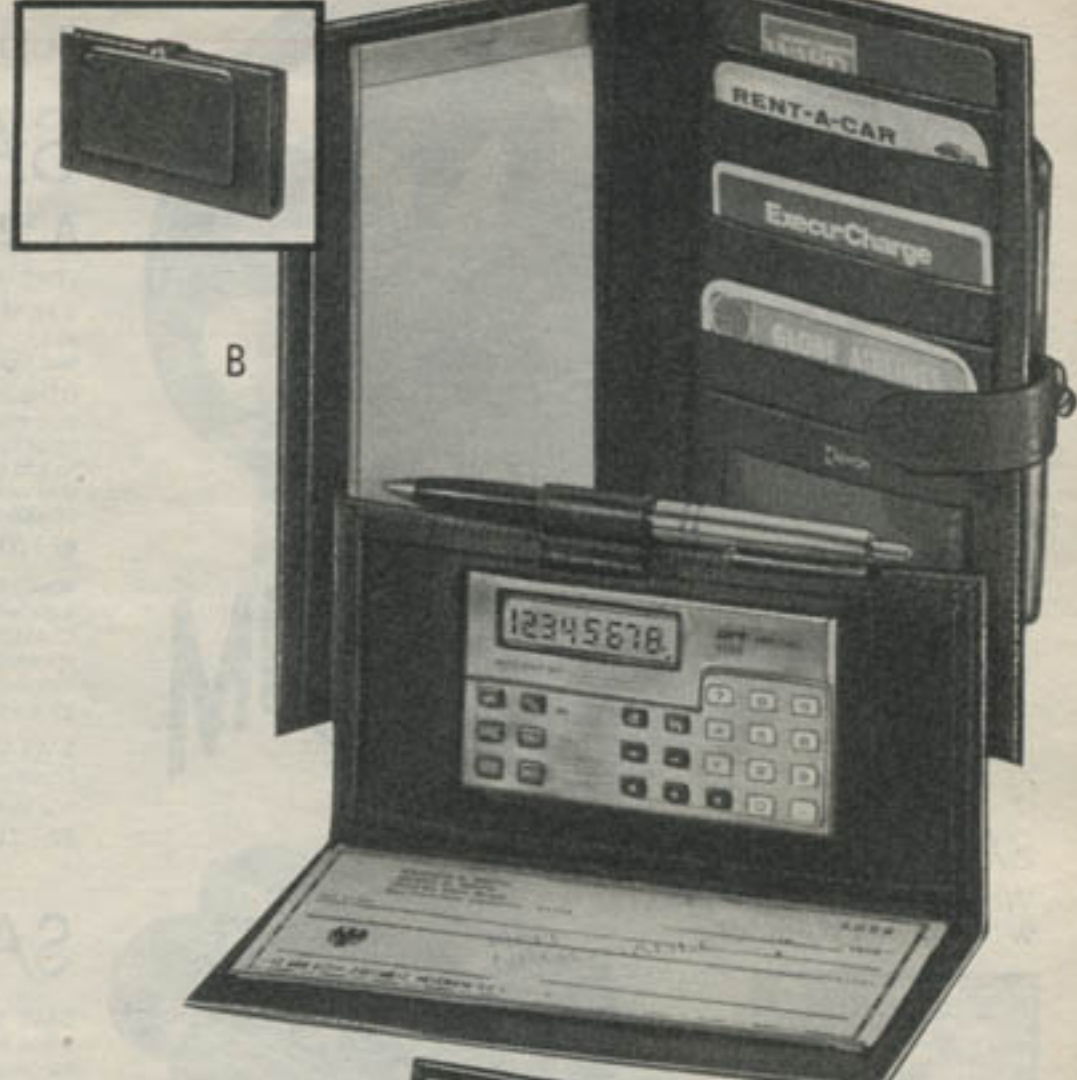
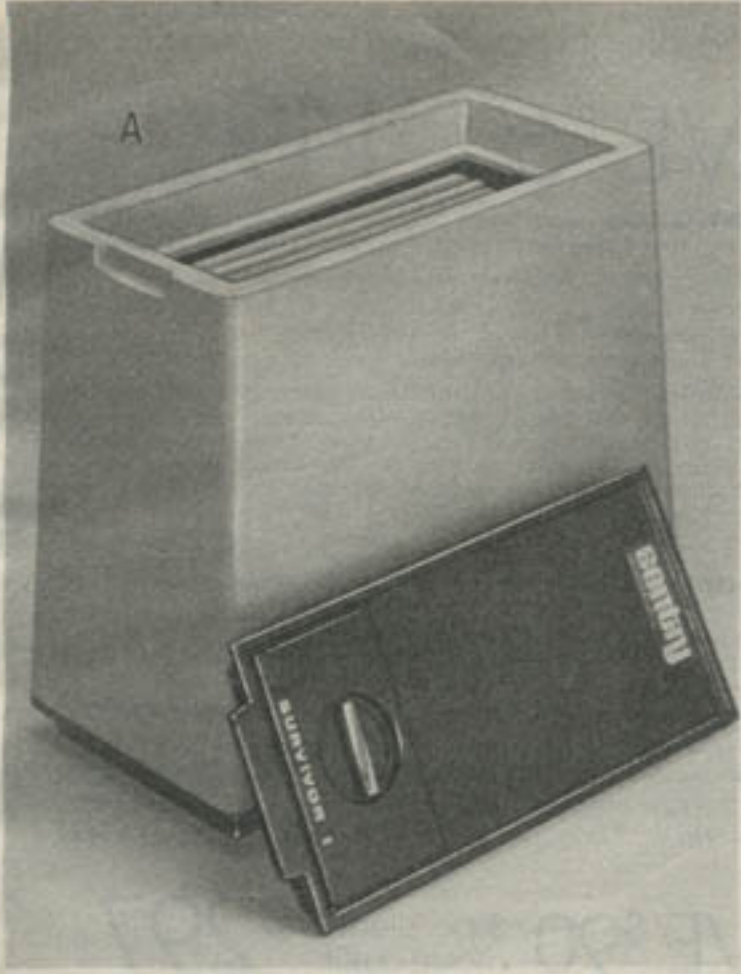

Choose the perfect gift

A NEW! Survivor "Master File" deposit box from Sentry is portable. It organizes and protects valuable records and documents that will fit into standard size file folders such as tax records, insurance policies, birth and marriage certificates and bank books. Gives 1700°F fire protection up to 1 full hour. Master File has the exclusive Sentry SURVIVACAST® insulation and exclusive removable key lock. Convenient top opening lets you place important files and documents with ease from the top (file folders not included). 7½x14¾x13¼ inches high.
67 T 9008 M—Shipping wt. 33 lbs. 49.99

B Give the perfect gift this holiday season—an all-leather French purse by Winston with built-in calculator. Uniquely styled with removable leather checkbook case, 7-pocket credit card and separate currency compartments, change purse, memo pad and ballpoint pen. 8-digit LCD credit card calculator is fully addressable with 4-key memory, automatic shut-off, memory-in-use indicator and percent key. Great organizer with compact styling. 3½x7¾x1½ in. wide.
67 T 8710—Ship. wt. 10 oz. 29.99

C NSC's NS 103-A Datachecker wallet with calculator. Three continuous memories hold data even when Datachecker is turned off. Perfect for keeping up-to-the-minute balance of checkbook plus 2 other charge accounts. Liquid crystal 8-digit display plus 5 full functions. Sleek, ultra slim (7.5 mm thin) brushed metal calculator case with pen, vinyl checkbook case and 2 batteries included.
67 T 8881—Ship. wt. 8 oz. 27.99

D Casio's MG 880 spacegame/melody maker calculator. Has game and musical functions, 4 basic calculations (+/-/x/+), memory, percentages and 8-digit LCD readout. Comes in fine leatherette case. 4½x2½x¼ inch deep.
GAME FUNCTION: Action-packed game has batteries of Earth's missiles engage incoming spaceships to prevent them from landing.
MUSICAL FUNCTION: Has 11 musical notes marked so you can play any tune you know—or plays a pre-programmed tune, "When the Saints Go Marchin' In."
67 T 8843—Ship. wt. 4 oz. 22.99

E Sharp EL-826 solar credit card calculator requires no batteries! Wallet-size calculator is powered by silicon solar cells which receive their power from natural and artificial light. Has 8-digit LCD display; 4 basic functions (+/-/x/+); one-touch percent key for add-on discount calculations; square root; and 4-key memory. Comes with vinyl wallet. 2½x3¾x¼ inches high.
67 T 8842—Ship. wt. 4 oz. 21.99

F Sharp EL-8061S miniature "watch-fob" clock/calculator with alarm. 8-digit LCD display calculator has built-in timepiece to show hour/minute/second. Calendar shows date and day of the week. Alarm sounds for appointments, meetings. Shows minus, error, set mode, A (AM), P (PM) and alarm indicators. Percent key for add-on/discount calculation. Includes vest-pocket watch chain and batteries. About 1½x2¾x¼ in. high.
67 T 8700—Ship. wt. 3 oz. 34.99

APF Hand Held Mathemagician Game

• 6 games plus teaching calculator • Built-in screen

39⁹⁵ or \$5 monthly—
see page 341 for
full credit terms

1 APF MATHEMAGICIAN HAND-HELD MULTIPLE GAME. A teaching calculator and device for game playing all in one. Can be played by children and adults of all ages. Simple or complex 1 or 2 digit problems can be performed. Four function calculator does multiplication, division, addition and subtraction. In addition, six games can be played—Goody Gumdrops, The Number Machine, Walk-the-Plank, Football, Lunar Lander and Countin' On (not shown). All games can be played by one or two people. In "Lunar Lander", you take over the controls of a lunar landing module at an altitude of 300 ft. above the moon's surface. Try and land the module safely! Switch to "Goody Gumdrops" and try to find the secret location of the gumdrop bomb before it explodes. In "Walk the Plank", you try to guess the machine's secret number in three tries. If you lose, you walk the plank! Durable plastic case is compact 8½"X5¼"X1½". Uses 9-volt battery (not incl. Order on p. 360). Warranted by manufacturer, see p. 336. X 917-2206 A—Mail. wt. 1.50 lbs.39.95



Goody Gumdrops



The Number Machine



Walk-the-Plank



Football



Lunar Lander



Coleco Telstar Combat TV Game

• 4 exciting tank games
• You maneuver your tank at various speeds

69⁹⁵ or \$5 monthly—
see page 341 for
full credit terms

2 COLECO TELSTAR COMBAT GAME. Four tank games—Night Battle, Camouflage Combat, Robot Battle and Combat. Now you're the Commander-in-Chief. Realistic dual tank controls allow you to maneuver and fire. Move all over the battlefield. Steer tanks through mine fields and other obstacles. Fire from any position. Score and number of shots register on screen. Two fisted action—3 forward speeds, 3 reverse speeds. Sounds of firing and explosions add to the excitement. Operates on six "C" cell batteries (not incl.—order on page 359). Order optional DC converter below under item [3]. It's simple to install with a screwdriver—takes just minutes, attaches to external VHF antenna leads on TV. Instructions included. Once the game is attached, there is no need to disconnect it. When the game is off it will not interfere with normal TV viewing. Plastic housing. Measures 12"X6"X18". Mail. wt. 5.25 lbs. Warranted by manufacturer, see p. 336. X 917-1968 A69.95



Night Battle



Camouflage Combat



Robot Battle



TV not included

2 Combat

Coleco Telstar Ranger TV Game

• 6 games in one
• Skeet and target games feature moving target

SAVE \$15 NOW ONLY **44⁸⁸**
This special price ends Dec. 24.

3 COLECO TELSTAR RANGER TV GAME. Six game system lets you play Tennis, Hockey, Jai-alai, Handball (not shown) and two exciting target games—Skeet and Target Shoot (not shown). Has Deluxe Console with two remote controls for play on or away from console. Electric photo-cell "Colt 45" pistol is used for target games. Skeet and Target games feature moving target. Three electronic sounds are heard—for a score, paddle contact or rebound. Has on-screen digital scoring. Variable speed and paddle control to fit the skill and age of players. Operates on six "C" cell batteries (not incl.—order on page 359). Order optional DC converter below. Measures 17½"X8"X6". Warranted by manufacturer, see page 336. Reduced from our Fall '77 Cat., page 718. After Dec. 24, order at Reg. Price. Mail. wt. 4.30 lbs. X 917-2123 AReg. \$59.88; NOW 44.88

DC Converter for Coleco® TV games. Converts 110-120 Volt. AC to DC. UL listed. Mailing weight 0.50 lb. X 917-1984 A6.95

See similar games in this catalog on p. 4, 5 and back cover. TV sets sold on page 518.

Buy now with our **Time Payment Plan**—see page 341

Your Search for VALUE Ends at Penneys



Tennis



Hockey



Jai-alai



Skeet Shoot

3 TV not included

JCPenney 319

ages 2 years
and up

Feeling good about the Playskool years **PLAYSKOOL**



★ MFR. REBATE
DETAILS ON P. 373

Teach-Me-Reader

129⁹⁹
item G

E 5.00 Manufacturer's Rebate. Fun-to-Learn Letters. Complete talking, learning program teaching letter recognition and basic spelling. Fun easy-to-use system for enjoying activities together or lets children discover ABC's by themselves. English, with Braille feature. About 18 x 4 x 15". Ages 2 and up. Requires 4 'D' batteries not incl.*

492 541 098—After rebate 84.99. Each 89.99

F 5.00 Manufacturer's Rebate. Fun-to-Learn Numbers. Talking, learning program teaches numbers, shapes, colors and basic addition. Abt. 18 x 4 x 15". Ages 2 and up. Requires 4 'D' batteries not included.* English; Braille feature. After rebate 84.99

492 541 099—Each 89.99

G 10.00 Manufacturer's Rebate. Teach-Me-Reader. Child can hear and enjoy stories any time. Electronic speech synthesis teaches basic reading skills to the non-reader. Incl. 12 books for a total reading program. About 28 x 16 1/2 x 4 1/2". Ages 3 and up. English. Requires 4 'C' batteries not included.*

492 541 078—After rebate 119.99. Each 129.99

A Alphonse II is programmed to make learning lots of fun! He'll provide music for a sing-along or a game of musical chairs. He also teaches math, spelling, matching, color memory and music. With correct answers he lights up and makes a happy sound. Includes four 2-sided activity cards. Automatic shut-off. About 9 x 5 x 11" high. Uses 4 'AA' batteries, not included*.

492 541 039—For ages 3 and up. Each 34.99

B Alphonse II Expander Kit. Reading, math, shape and color recognition. Each kit includes 4 two-sided activity cards, gameboard, playing pieces. Instruction guide. Ages 3 and up.

492 541 102—Numbers, letters and shapes. Each 7.99

492 541 103—Seasons and Change. Each 7.99

492 541 104—Wheels, Wings and Things. Each 7.99

492 541 105—Animal Kingdoms. Each 7.99

492 541 106—How we Work. Each 7.99

C 5.00 Manufacturer's Rebate. Electronic Talk 'N' Play™...winner of the 'Toy Technology Award', see 'Award Winning' on page 373. Exceptionally designed to provide an entertaining learning system for young children. Stories, songs, games and activities in an easy-to-use audio-visual program complete with tape playing/recording system. Also plays standard cassettes. Includes one cassette tape and follow-along book (others sold sep. below). Abt. 13 1/2 x 17 1/2 x 6 1/2" h. Ages 3 1/2 and up. Uses 4 'D' batteries or AC adapter, not incl.*

492 541 085—English. After rebate 84.99. Each 89.99

D Talk 'N' Play Cartridges in English only with book included.

492 541 115—Lovable Old Grover. Each 12.99

492 541 116—Puzzles and Games. Each 12.99

492 541 117—Big Bird Alphabet Book. Each 12.99

492 541 118—Cookies for Sale. Each 12.99

492 541 119—Lets Play School. Each 12.99

*Batteries sold on page 398; AC adapter sold on opposite page

SPACE:1999

From Out of the Future



Front cockpit and rear jet remove and snap together for scouting missions

Spaceship Eagle 1

Exciting Details inside and out—complete with three crewmen—and it's two ships in one!

13⁶⁶

Challenge the Universe—be the captain of the Eagle 1 Spaceship. Inside it's a detailed command center—outside it's two ships in one. Front cockpit and rear jet engine can be removed and snapped together—they form a smaller exploratory craft perfect for scouting missions. Comes with three authentic-looking crew members: Commander Koenig, Doctor Russell, and Professor Bergman. Ship is about 31 in. long. Includes a working space crane, 2 chairs, laser rifle, 4 stun guns and weapons rack. Metal, vinyl and plastic.
X 924-8741 A—Mailable: weight 4.0 lbs..... 13.66

1
Space 1999 Stun Gun with light ray and "stun" sound
6⁷⁷

2
18⁸⁸ pair
Comlock Communicators

1 Space 1999 Stun Gun[®] with Stun Sound! Multi-colored blinking lights—plus bright beam to project images. Comes with 3 projection discs. Lights and sound can be operated independently or together. Plastic, 8-in. high. Uses 2 "C"-cell batteries (not included, order below). Hong Kong.
X 924-8758 A—Mailable: wt. 1 lb..... 6.77
"C"-Cell Batteries. Sold in package of 6.
X 959-0767 A—Mailable: wt. 0.95 lb..... 1 pkg. 1.39

2 Space 1999 Comlock Communicators[®]. Just like the walkie-talkie used on TV. 3-toned signaling system lets you talk or send Morse code. Comes with slide-in pictures of your favorite characters from the show. Plastic. 12-in. high. Use one 9V battery each (not included, order below). Ages 8, up.
X 924-8766 A—Hong Kong. 1.50 lbs..... pair 18.88
9-Volt Battery. Sold in package of two.
X 959-0084 A—Mailable: wt. 1 lb. 1 pkg 1.19

3
Wrist Radio
8⁴⁴

Chestpack Radio/Amplifier
12⁸⁸

3 Space 1999 Wrist Radio[®]. Solid-state radio plays all AM stations. Adjustable strap. Face measures 2½x2½x1 in. thick. Plastic and metal. Uses 1 "AA"-cell battery (not included, order below).
X 924-6778 A—Hong Kong. 0.50 lb..... 8.44
"AA"-Cell Batteries. Sold in package of 4.
X 957-1902 A—Mailable: wt. 0.40 lb..... 1 pkg. 99c

4 Chestpack Radio/Amplifier[®]. Solid-state 5-transistor AM radio also has microphone for broadcasting commands—or singing along with favorite tunes. Morse code transmitter and earphone for private listening. 5½x2½x7¼-in. high overall. Plastic. Uses two "C"-cell batteries—not included, order under [1]. For ages 8 and up. Hong Kong.
X 924-8832 A—Mailable: weight 2.0 lbs. 12.88
©1975, 1976 ATV Licensing Limited.

5 Moonbase Alpha \$8.99
Figures sold separately, \$3.33 ea.

SAVE \$2.14 when you buy playset and 3 figures together only **16⁸⁴**

5 Space 1999's Moonbase Alpha[®]. The hub of activity from that famous TV show. Includes 8-in. high, simulated computer, chair and hassock. Computer console flashes on and off—uses one "D"-cell battery (not included, order below). Set up, it's about 30x17x11-in. high. Printed vinyl.
X 924-8790 A—Mailable: wt. 3.0 lbs..... 8.99
"D"-Cell Batteries. Package of 6.
X 957-1761 A—Mailable: wt. 1.40 lbs..... 1 pkg. 1.39

6 to **8** Space 1999 Figures. Each 9-in. tall. Vinyl. Mail: wt. 0.25 lb.
X 924-8824 A—[6] Doctor Russell[®] 3.33
X 924-8816 A—[7] Professor Bergman[®] 3.33
X 924-8808 A—[8] Commander Koenig[®] 3.33
SAVE \$2.14 when you buy Moonbase and all three figures together.
X 924-8782 A—Mailable: wt. 3.50 lbs..... Set 16.84
©1975, 1976 ATV Licensing Limited.



TOYS AREN'T JUST FOR CHRISTMAS. Save this catalog. You can order anything on these two pages—at these low prices—until August 13, 1977.

NOW—Our New Improved Portable Video Recorders Are Even Lighter and More Compact Than Before! They'll Go Most Anywhere—Outdoors or Indoors—Record Live Action or Your Favorite TV Shows! Record Live Action or Your Favorite TV Shows!



Video record the action and the sound



View the tape "instantly" on your TV



New "stop-action" feature . . . see below left

Check These Exciting New Features:

- Portable VCR is approximately half the size and weight of last year's model
- New 6-hr. recording capability compared to 4 hours previously
- New 14-day programmable tuner enables you to record up to 8 different TV programs over a period of two weeks, has timer back-up in case of temporary power failure
- During playback (on 6-hr. mode), new stop-action or slow-forward feature freezes the frame so that you can view one frame at a time . . . ideal for "slide shows" or checking your golf swing, tennis stroke, etc.



Color Camera has built-in black and white monitor that lets you view what you've just shot on instant playback



B
Deluxe Color Camera

A
Portable VHS Recorder with Programmable Tuner



During playback, remote pause control feature lets you "stop the action" from the comfort of your chair





Word Processing



Spreadsheet



commodore

4 programmed function keys with up to 8 user-defined functions possible.



Horizontal and vertical cursor control keys

A



15-character LCD enables you to correct and edit from memory

Repeat typing for all keys and functions

Variable 10, 12, 15 and proportional space typing

Changeable type wheel in 5 styles:
Script 1012, Quadro 15, Quadro 1012, OCR-B, Pica

A



Save \$70

499.99 No money down
 \$25 a month*

Executron 68... Brother's® newest advanced electronic typewriter

A Finally, an affordable compact electronic office typewriter with some of the most unique features you'll ever find on a typewriter in its price range! 5,000-character memory for text and phrase storage. The text memory is used for editing copy and the phrase memory can be used to store often-used names, addresses and short phrases. 15-character liquid crystal display enables you to correct and edit from memory. Variable 10, 12, 15 and proportional spacing, right margin justification that perfectly aligns the right hand margin, automatic centering, automatic return, automatic underlining and bold print capability.

Executron 68 also includes one-line memory for automatic lift-off correction, as well as automatic relocation key, decimal tabulation, repeat typing for all keys, one-touch interchangeable "cassette" type daisy wheel and auto paper feed.

Add the optional interface module (on opposite page) and it also becomes a letter-quality printer for your home or personal computer. Also has bi-directional printing from memory. Manufacturer's Warranty.** Was 569.99 in our 1984 Fall Big Book, page 708. Buy ribbons and correction tape on opposite page.

62 G 98394 MS—Ship. wt. 27 lbs. now 499.99

B



249.99 No money down
 \$15 a month*

Brother® electronic typewriter

B Brother® Student-Riter XLI . . . the perfect gift for anyone in high school, college or graduate school. One-touch interchangeable "cassette" type daisy wheel. Cassette ribbon pops in and out for tangle-free, mess-free ribbon changes. Tabulator—one touch for tab, set or clear. Repeat typing for all keys. Automatic relocation. 20-character memory for automatic lift-off correction. Variable 10 and 12-pitch typing. Variable 1, 1½, and 2-line spacing. Standard office keyboard.

Built-in handle and lid cover makes this typewriter portable. Manufacturer's Warranty.** Buy ribbons and correction tape on opposite page.

62 G 98391 MS—Ship. wt. 16 lbs. 249.99

Save \$70

299.99 No money down
 \$17 a month*

Silver Reed multi-print electronic typewriter

C It's capable of printing on both thermal and normal paper; it offers a large range of characters and symbols (180) without the bother of changing printing elements. Has letter-quality dot-matrix print. Cassette ribbon for mess-free ribbon changes.

In addition to the standard keyboard front and Print Pitch Selector (10 pitch for pica, 12 pitch for elite), there is a Print Pattern Selector. It allows you to choose any of the following 6 print patterns: normal, bold, double bold, enlarged, automatic underline and shadow. Plus, the Correction Print feature lets you correct errors in any style before they're printed on paper. Even has a built-in port to connect to interface module (sold at right) and allow EXD 15 to become a letter-quality computer printer. Interface module connects to your home or

C



personal computer. Some computers may require an additional interface or cable at the computer. Manufacturer's Warranty.** Was 369.99 in our 1984 Fall Big Book, page 709.

62 G 98301 MS—Ship. wt. 16 lbs. . . 299.99

Computer interface module for 98301 above. For RS232C serial. For use with Commodore 64, VIC 20.

62 G 98311—Ship. wt. 2 lbs. 129.99

For Centronics parallel. For use with Atari 400/800, TRS-80 III and IV, Apple II, IBM PC.

62 G 98312—Ship. wt. 2 lbs. 129.99

Ribbon for Silver Reed 98301. Pkg. of 2.
 62 G 98302—Ship. wt. 4 oz. pkg. 7.99

*Montgomery Ward Credit customers: This purchase may change your monthly payments depending on the highest balance on your account. Does not apply to AZ, NM and OR residents. See page 497.

**Write for a free copy of Manufacturer's Warranty, see page 497.

VECTREX

The self-contained system with graphics you can't find outside an arcade!

Cut \$100
Was \$199.99
\$99.99



New at Sears!

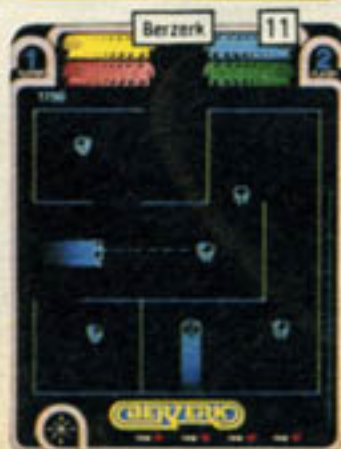
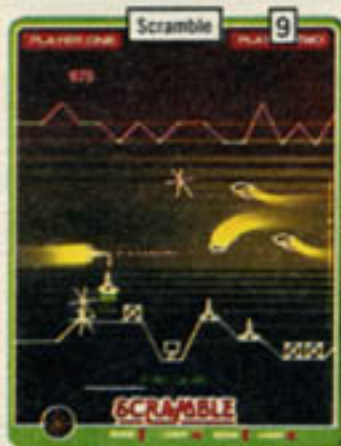

Most home video game systems are only as good as the TV they're hooked up to. Vectrex has no such limitations since it's completely self-contained . . . requires no hook-up to anything but an electrical outlet. Built-in 9-in. diagonal screen uses the same display technology as some coin-arcade games, for the same quality images and movements . . . including 3-D rotation and zooming. Solid-state circuitry delivers more power and speed than other home arcades. Full fidelity speaker is the same as many coin-arcade machines . . . can even produce realistic voices without any special attachment. Built directly into console is the fast-paced game, Mine Storm. Detachable control panel features joystick and fire buttons. Whole panel slides under screen for easy storage. Warranted by G.C.E., see page 323. UL listed for 110-120-volt, 60-Hz., AC. Reduced from 1982 Wish Book, p. 637.
49 C 65652C—Shipping weight 16 pounds Was \$199.99; Now \$99.99
49 C 65931—Extra Control Panel. Shipping weight 1 pound 34.99

(1 thru 11) Each cartridge includes color overlay to customize the screen. Second control panel needed for 2-player games. Warranted by G.C.E., see p. 323. Wt. 5 oz.

Cartridge name and description	Catalog Number	Price
(1) Fortress of Narzod. Destroy deadly guardians and monstrous gatekeeper of the enemy fortress.	49 C 65910	\$32.99
(2) Spike tells you of his progress as he attempts to rescue his girl from the maniacal monster. No special attachment for voice.	49 C 65914	37.99
(3) Heads-up. Exciting soccer action with thrilling true-to-life field perspective. 1 or 2 players	49 C 65918	37.99
(4) Spinball Pinball. Test your eye-hand coordination—dangers lurk. Two balls double the challenge!	49 C 65917	32.99
(5) Web Wars. Vaporize the spider's web and capture the creatures. As the score soars, the game gets tougher.	49 C 65915	37.99
(6) Clean Sweep. Vacuum money strewn around a maze of bank corridors before the thieves catch you or turn off the lights.	49 C 65907	32.99
(7) Hyperchase. Race by cliffs, trees, skyscrapers, thru city streets and country highways.	49 C 65909	32.99
(8) Blitz. Football action includes runs, passes, punts, field goals. 1 or 2 players.	49 C 65908	37.99
(9) Scramble. Knock out enemy rockets, fuel tanks, missile bases when you zoom over head.	49 C 65902	37.99
(10) Star Trek. Fly thru 9 sectors of space to seek out and destroy the enemy. When you are hit, the whole screen crumbles.	49 C 65904	37.99
(11) Berzerk. Maneuver the humanoid with laser gun to liquidate robots as you move from maze to maze.	49 C 65901	32.99

1TM of Paramount Pictures Corp.



Little Professor™ II
\$11.99



1 Learning can be fast and fun with the Little Professor™ II. Your child can sharpen math skills on 4 levels of play, with 2 chances to answer before correct answer is displayed. Correct answers get a smile from the professor and a star on the screen. Automatic shut-off after 2 minutes of non-use. Uses 2 "AA" batteries, sold sep. on p. 404. Warranted by Texas Instruments.*
For ages 5 years and up.
49 N 17604—Shipping weight 5 ounces... \$11.99

2 Talk 'N Teach™ is a teacher-on-tape that makes learning fun because it actually talks to children. Comes with 24 pre-recorded voice/workbook cards that ask questions about the alphabet, colors, shapes, animals and more, then, pauses to let children answer. Flip the cards over and there's a colorful exercise to reinforce the audio lesson. Each set also has 2 blank message cards so kids and parents can make their own messages. Warranted by Connor.* Requires 4 "D" batteries, sold separately on p. 404. For ages 3 years and up.
49 N 17775—Shipping weight 3 lbs. 8 oz... \$39.99

3 thru 8 Additional voice/workbook card packs include 24 voice cards plus 2 blank message cards.
(3) 49 N 17777—"Numbers." Wt. 8 oz... \$8.99
(4) 49 N 17778—"Shapes." Wt. 8 oz... \$8.99
(5) 49 N 17779—"Colors." Wt. 8 oz... \$8.99
(6) 49 N 17780—"Letters." Wt. 8 oz... \$8.99
(7) 49 N 17781—"Animals." Wt. 8 oz... \$8.99
(8) 49 N 17782—"Where Is It?" Wt. 8 oz... \$8.99

9 Thousands of arithmetic problems, 5 games and a lively little LCD man make the Math Master™ a joy. 3 levels of play keep it challenging. Requires 2 "AA" batteries, sold separately on page 404. For ages 4 to 12 years.
49 N 17601—Shipping weight 1 lb. 3 oz... \$19.99

10 The Spelling Master™ is a super way to develop and practice spelling skills. 150 words are stored in its memory bank to provide your child with 5 fun, educational games. Styled like a computer and has a membrane keyboard, LCD readout. Also incl. a comprehensive manual. Requires 2 "AA" batteries, sold separately on page 404. Was \$29.99 in our 1986 Toy Specialog, page 532. For ages 4 to 10 yrs.
49 N 17947—Shpg. wt. 1 lb. 1 oz... Now \$24.99

11 Dial-A-Teacher™ is a talking toy that helps prepare your child for early school years. By "dialing" up questions on the telephone dial, kids can learn the basics of spelling, math, music and more. Answers are punched in on the touch-pad keyboard. To change the subject, just remove one card and clip in another (5 two-sided cards included). Automatically shuts off after 2 minutes of non-use. Requires 4 "C" batteries, sold separately on p. 404. Additional programs available below. Warranted by VideoTech*. Was \$39.99 in our 1986 Toy Specialog, p. 533. For ages 3 to 6 years.
49 N 17901—Shpg. wt. 2 lbs. 12 oz... Now \$34.99

12 and 13 Additional programs for (11). Each includes a cartridge and 5 overlays.
For ages 3 to 6 years.
(12) 49 N 17902—Alphabet Fun
(13) 49 N 17903—Number Fun
Shipping weight 1 lb. 2 oz... Ea. \$12.99
*Write for free copy, see page 371.



Talk 'N Teach is a teacher-on-tape
\$39.99

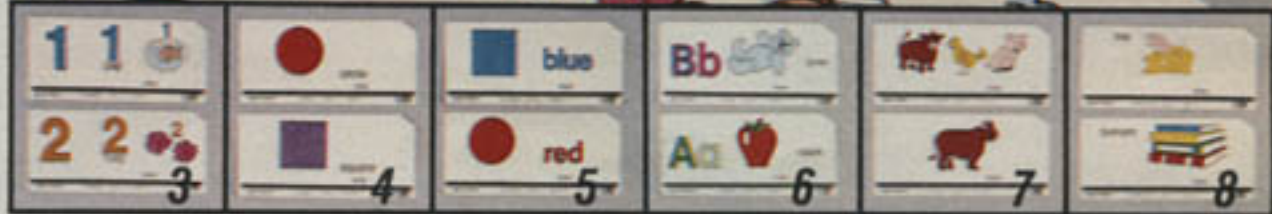

Math Master \$19.99



Spelling Master \$24.99



Dial-A-Teacher™ \$34.99

"THAT IS CORRECT"



"Alphabet Fun" helps children identify words, letters and objects



"Numbers Fun" introduces your child to numbers in a delightful way



Get an academic assist

Only
\$43.99



INTEREST

$15 \times 5 = 75$



1. Talkatron makes education a game! 7 spelling and 3 math games offer your child hours of fun, but more importantly, lots of learning. It talks too. It lets your child know if an answer is right or wrong, plus says words to be spelled and more. Talkatron has a vocabulary of over 150 words. Modules sold below expand spelling game vocabulary. Enter game modes, levels and answers on the reliable membrane keyboard. Requires 4 "C" batteries, sold separately on p. 459; or use with AC adapter, sold below. Shuts off after several minutes of non-use to conserve power. For 1st thru 8th grades.
49 C 17709—Shipping weight 2 lbs. . . **\$43.99**

2 and 3. Expansion modules for Talkatron spelling games. Each expands vocabulary by an additional 160 words.
2. 49 C 17729—For grades 1 and 2. Wt. 4 oz. . . **\$12.99**
3. 49 C 17732—For grades 3 and 4. Wt. 4 oz. . . **\$12.99**

4. The Spelling Master™ is a super way to develop and practice spelling skills. 150 words are stored in its memory bank to provide your child with 5 fun, educational games. Styled like a computer and has a membrane keyboard, LCD readout. Also incl. a comprehensive manual. Requires 2 "AA" batteries, sold on p. 459. For ages 4 to 10 yrs.
49 C 17947—Shipping weight 1 lb. 1 oz. . . **\$29.99**

5. Thousands of arithmetic problems, 5 games and a lively little LCD man make the Math Master™ a joy, 3 levels of play keep it challenging. Requires 2 "AA" batteries, sold sep. on p. 459. For ages 4 to 12 yrs.
49 C 17601—Shipping weight 1 lb. 3 oz. . . **\$19.99**
AC adapter for (1), above (not shown).
49 C 17806—Shipping weight 1 lb. 3 oz. . . **\$9.99**

6. The Quiz Wiz™ tests your knowledge. With 1001 questions on a variety of subjects. Lights and sound effects let you know whether your answers are right or wrong. Play alone or with friends. Requires one 9-v. battery, not included, sold on p. 459. Warranted by Coleco.
For ages 8 years and up.
49 C 17675—Shpg. wt. 1 lb. 6 oz. . . **\$24.99**

7. Reader's Digest® "Q & A" computer is a question and answer game. Quizzes on a variety of topics. Includes 2 programmed games, each with over 3000 questions on 156 separate exams to test your wits in sports, music, history, entertainment and more. The element of chance is added too . . . extra points scored by random flashing lights heighten the fun. Play alone or compete with friends. Additional games sold below. Requires one 9-v. battery, not included, sold on p. 459. Warranted by Selchow & Righter.
For ages 8 years and up.
49 C 17661—Wt. 2 lbs. 2 oz. . . **\$39.99**

Additional game programs for (7) above (not shown). Each has over 1200 questions arranged in 61 quizzes.
Shipping weight 5 ounces.
49 C 17666—College Prep Math . . . **\$3.99**
49 C 17667—College Prep Reading . . . **\$3.99**
*Write for free copy, see page 335.



Space Communication Helmets



1

1977
Each



2

1 & 2 Star Force Plastic Space Helmet Walkie-Talkie. Built-in 5-transistor walkie-talkies. Send or receive voice or code. Adjustable speaker/mouthpiece, volume control. Up/down visor, polyurethane foam padding, adjustable chin strap, spring loop antenna. Uses one 9-volt battery*. Ages 5 to about 12. Imported from Hong Kong. Del. wt. 2.25 lbs.

[1] White Helmet with Star Force Commander Insignia.
XU 925-9268 A 19.77

[2] Black Helmet with Ogar Insignia.
XU 925-9276 A 19.77

4-TR
Police
Style

1477
Pair

3

Walkie-Talkies

4

4-TR
Space
Explorer

1788
Pair



6-TR
1988
Pair

5

3 Pair of 4-Transistor Police-Style Walkie-Talkies with Morse Code. Call button for signaling, police codes. Flexible coil antenna. Volume control, on/off switch. Belt clip. Plastic. 1 1/4 x 2 1/2 x 5 1/2 in. high. Set uses two 9-volt batteries*. Ages 5 to about 10. Imported from Korea. Del. wt. 1 lb. XU 928-5933 A Pair 14.77

4 Pair of 4-Transistor Space Walkie-Talkies. Transmit and receive voice or Morse Code messages. Volume control, on/off switch, key for Morse Code. Telescopic antenna. 3 1/4 x 7 x 3 1/4 in. plastic case. Set uses two 9-volt batteries*. Ages 5 to about 10. Imported from Korea. Del. wt. 1.25 lbs. XU 925-9326 A Pair 17.88

5 Pair of 6-Transistor Walkie-Talkies. Controls for talking or sending Morse Code. (Morse code chart plate is permanently attached under speaker.) Telescopic antenna. On/off/volume control. Plastic. 3 x 1 1/4 x 7 3/4 in. long. Set uses two 9-volt batteries*. Ages 5 to about 10. Imported from Hong Kong. Del. wt. 1.40 lbs. XU 928-6683 A Pair 19.88

Wireless Mikes

6

Donny and Marie
857

7

Barbie
857

8

AM/FM Radio
1244

6 & 7 Wireless Mikes Let You Be a Star. Tune to the indicated frequency, press the button, and your voice comes out of your own radio! Plastic. Uses one 9-volt battery*. Ages 8 to about 12. Imported from Hong Kong.

[6] Donny and Marie AM Mike. 11 in. long. Use with any AM radio. Antenna. XU 925-3469 A—Del. wt. 0.50 lb. 8.57

[7] Barbie FM Mike. 13 in. long. Use with any FM radio. Wire antenna. XU 928-5974 A—Del. wt. 0.75 lb. 8.57

8 AM/FM Portable. Great for use with wireless mikes [6] & [7]. 9-transistor, solid state. Telescopic antenna, rotary dial, on/off/volume control. Plastic. 3 x 1 1/4 x 5 in. high. Uses one 9-volt battery*. From Hong Kong. Ages 8 and up. XU 928-6691 A—Del. wt. 0.60 lb. 12.44

9 to 13 "That's a Radio?" Radios. Great for use with wireless mikes [6] and [7]. Solid state, transistorized radios have wacky, "looks like something else" plastic bodies. Each uses one 9-volt battery*. Imported from Hong Kong.

[9] Hot Dog AM Radio with Mustard. 5 transistors. Carry strap. 8 1/2 x 2 1/4 in. Del. wt. 0.70 lb. XU 928-5883 A 8.39

[10] Gold Record AM/FM Radio. Tiny L.E.D light flashes in sync with the sound. 9 transistors. Sectional antenna for FM. 2 x 2 3/4 x 6 3/4 in. high. Del. wt. 1 lb. XU 928-6709 A 18.88

[11] to [13] Soda Can AM Radios. 6-transistors. 2 1/4 in. metal grille speaker at top end. 4 3/4 in. high. Del. wt. 0.75 lb. XU 928-5867 A—[11] 7-Up® 6.39
XU 928-5875 A—[12] Pepsi-Cola® 6.39
XU 928-5859 A—[13] Coca-Cola® 6.39

*Batteries not included, see page 461.

Fun-Styled Radios

10
1888

Soda Can
AM Radios
639
Each

9

839

11

13

12



Save \$20 on Commodore computer and \$20 on peripherals B, C, E, F or G when you buy two or more units

49.99-299.99

A No money down, \$15 a month.* Commodore 64 personal computer has 64K RAM built-in user memory. Full-size typewriter keyboard with 66 keys, upper and lower case letters and four unassigned programmable function keys to provide user full control. Display of 40 columns x 25 lines, 255 combinations of border/background colors, 16 text colors, 64 PET graphic characters and high resolution mode provide creative versatility. Has three independent voices, each with a nine-octave range. Mfr.'s style number C64. Mfr.'s Warranty.**
 67 G 20003 LSD—Ship. wt. 11 lbs. alone 219.99
 Save \$20 when bought with either (B), (C), (E), (F) or (G) 199.99

B No money down, \$16 a month.* Commodore single disk drive unit uses standard 5¼-inch floppy diskettes to store programs and data. Each diskette holds up to 170,000 characters of information. Disk drive includes its own microprocessor and memory and doesn't require extra interfaces or cables. Manufacturer's style number 1541. Manufacturer's Warranty.**
 67 G 20142 LSD—Ship. wt. 12 lbs. alone 269.99
 Save \$20 when bought with either (A), (C), (E), (F) or (G) 249.99

C No money down, \$17 a month.* New Commodore dot matrix printer is a 60-character per second near letter-quality, high-performance printer. Ideal for printing hard copies and creating printouts from VIC 20, Commodore 64 and Plus/4 computers. Has graphic capabilities, prints 80 columns bi-directionally. Also capable of printing digits, special symbols, graphic characters and dot programmable graphics. Mfr.'s style number 1526/MPS 802. Mfr.'s Warranty.**
 67 G 20124 LSD—Ship. wt. 20 lbs. alone 319.99
 Save \$20 when bought with either (A), (B), (E), (F) or (G) 299.99

62 G 40187—Ribbon for Commodore 1526/MPS 802 printer. Wt. 1 oz. . . 17.95
 Commodore printer/plotter (not shown) produces charts and graphs in 4-color. Connects directly to VIC-20 or Commodore 64. Mfr.'s Warranty.**
 67 G 20172—Ship. wt. 5 lbs. 4 oz. 99.99

D Computermate floppy disk organizer. Holds sixty 5¼-inch computer disks. Section dividers for easy access. Multiple index cards.
 62 G 3429—Manufacturer's Warranty.** Ship. wt. 1 lb. 13 oz. 11.99

Floppy disk storage box (not shown). Holds twenty 5¼-inch computer disks.
 62 G 3428—Ship. wt. 1 lb. 5 oz. 7.99

E High-quality Zenith 12-inch monochromatic video monitor. Features crisp character definition in green phosphor display. Concealed front panel controls and LED power-on indicator. Order hook-up cables on page 525. Manufacturer's style number ZVM 123. Manufacturer's Warranty.**
 67 G 20400 LSD—Ship. wt. 14 lbs. alone 119.99
 Save \$20 when bought with either (A), (B), (C), (F) or (G) 99.99

F Commodore datasette recorder stores data and programs on standard low-cost audio cassette tapes. Has tape counter. Attaches directly to VIC 20 or Commodore 64 computers. For use with all cassette format software. Manufacturer's style number 1530. Manufacturer's Warranty.**
 67 G 20102 LSD—Ship. wt. 2 lbs. 6 oz. alone 69.99
 Save \$20 when bought with either (A), (B), (C), (E) or (G) 49.99

G Commodore telephone modem gives access to other computers over ordinary telephone lines. Allows user to gain access to large data bases such as The Source, CompuServe, Dow Jones News/Retrieval Service and other timesharing services. Plugs directly into user's port, connects to any modular jack telephone. Includes Term I terminal program on tape. Manufacturer's style number VIC 1600. Manufacturer's Warranty.**
 67 G 20132 LSD—Ship. wt. 1 lb. 6 oz. alone 69.99
 Save \$20 when bought with either (A), (B), (C), (E) or (F) 49.99

H Commodore Magic Voice speech module adds a new and exciting dimension to computing. Over 230 words built-in so you can teach spelling, create sentences or play the talking game cartridges Gorf and Wizard of Wor (plus others to come). Has simultaneous voice and graphics action. Features top-loading cartridge port that accepts all talking and non-talking cartridges. Compatible with Commodore 64 and SX64 computers. Mfr.'s Warranty.**
 67 G 20182 LS—Ship. wt. 13 oz. 59.99

I Commodore joystick controller for Commodore 64 and VIC 20 computers. For one player only. Manufacturer's Warranty.**
 67 G 20112—Ship. wt. 8 oz. each 9.99

J Wico arcade quality joystick control . . . the ultimate in one-hand control! Bat handle grip fits comfortably in your hand and offers smooth, responsive 8-position movement. Rugged compact base with rubber grip pads, 2 fire buttons—one on handle, one on base. For Commodore 64 and VIC 20, Atari 400, 800, 600XL, 800XL, 1200XL computers and Atari and Sears video games. Manufacturer's Warranty.**
 62 G 1563—Ship. wt. 1 lb. 3 oz. each 24.99

K Commodore game paddles for 2-player game action on Commodore 64 or VIC 20 computers. Full rotation with fire button. Required for selected Commodore software. Manufacturer's Warranty.**
 67 G 20152—Ship. wt. 10 oz. pair 14.99

*Montgomery Ward Credit customers: This purchase may change your monthly payments depending on the highest balance on your account. Does not apply to AZ, NM and OR residents. See page 497.

**Write for a free copy see page 497.
 Order software and accessories on pages 518 and 520.

Here's something our competition doesn't want you to see. Talking Computron™ promotes more learning skills than most other toys of its kind!



\$10 less
thru 12/15/88
\$39⁹⁹

1 It's fun, challenging and a great way to learn!

With almost twice the child-pleasing activities of our original Computron™, plus a friendly "computer" voice, the Talking Computron™ is the learning toy you have been looking for. When you turn Talking Computron™ on, the verbal tutor will ask you to select one of the 19 fun-filled activities. This chatty playmate boasts a delightful 120-word vocabulary for spelling, pronunciation and word games. Math quizzes feature 3 levels of play and you have 3 musical activities to choose from. Your responses on the smooth, touch-sensitive keyboard quickly register on the unit's LED screen. Uses AC power adapter (2) below, or 6 "C" batteries, sold separately on page 406.

For ages 5 years and up.

49 N 17727—Wt. 3 lbs.

Price thru 12/15/88 . . . \$39.99; After 12/15/88 \$49.99

2 Play with Talking Computron™ for as long as you like, without replacing any batteries! The AC power adapter for (1) is UL listed. Not recommended for ages under 5.

49 N 17995—Wt. 10 oz . . . \$9.99

3 thru 6 The fun never has to end when you add the additional cartridges to Talking Computron's™ vocabulary. Each additional cartridge expands the vocabulary by 100 words. Colorfully illustrated storybook included.

(3) 49 N 17865—Let's Visit the Zoo

(4) 49 N 17867—A Day to Bake

(5) 49 N 17869—Dress-up and Theatre

(6) 49 N 17871—Rocket to Zenod

Wt. each 7 oz . . . Each \$9.99

Save this catalog . . . order most toys thru August 31, 1989!

You can order any item on pages 308 thru 493, now thru 8/31/89 . . . unless otherwise stated

Helps teach spelling, math and the alphabet. Expands the powers of logic and enhances musical awareness

"Guess that word?"
(Answer: "Smaller")

REMSALL

"What does 6 minus 2 equal?"
(Answer: "6 - 2 = 4")

6 - 2 = *

"What sign goes here?"
(Answer: "8 + 5 = 13")

8 * 5 = 13



You'll spend less on batteries with our AC adapter



\$9⁹⁹ each Additional word cartridges for Talking Computron™

TELE-GAMES

ELECTRONIC



PONG™ SPORTS IV

- Individual or team matches for 2 or 4 players
- Attaches to your present television
- Automatic ball speed-up after 4 and 8 hits
- Game selection button on console at your command

\$24⁹⁵

CONSOLE: 6x10x3-inch high console of high-impact plastic. Game selection button on top. Start button begins game. Automatically serves the ball. Console emits an electronic beep when the ball is hit or a point is scored. Automatically speeds ball up after 4 or 8 hits. On-screen scoring and paddles are in color on color TV. Solid state.

PADDLE CONTROLS: Four remote paddle controls with 68-inch cords. **INSTALLATION:** Simply attach game switch to TV antenna terminals (TV not included), plug console into game switch and tune your set to channel 3.

ORDER INFO: Operates on 4 "C" batteries (not included, order on page 651) or with AC adapter sold below. Instructions, rules included. See Warranty at right. *For use with AC house current order adapter with game below.*

- Game only.
 6 C 99708—Shipping weight 3 pounds 8 ounces \$24.95
 Game with AC adapter. 6-volt. UL listed. 20-foot cord.
 6 C 99795—Shipping weight 4 pounds 2 ounces \$31.90
 AC Power Adapter only. For use with Sears Tele-Games® 6 C 99708. 6.0-volt. UL listed. 20-foot cord.
 6 C 99702—Shipping weight 10 ounces \$6.95



Stunt Cycle: Jump and clear 8 to 32 buses in a chain while you control your cycle's speed, avoiding crashes and racing against time. For one player. Rating chart for comparison. 4 variations.



Team Pong: Super-fast Pong action for 2 or 4 players. Play with 3 paddles to a team. Automatic ball speed-up. Score 15 to win. 8 game variations.

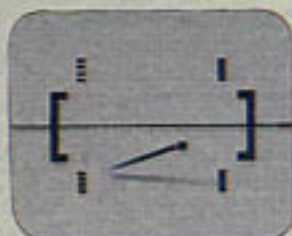

Street Hockey: 4 barriers add faster and more puck movement as it ricochets off goal posts and barriers. For 2 or 4 players. 8 game variations.

MOTOCROSS SPORTS

An exciting 20-game unit with twist-throttle handgrip controls for 4 wild cycle games . . . plus 4 plug-in controls for challenging paddle sport action

\$34⁹⁵

CONSOLE: Motorcycle-styled plastic console is 9½x15x5-inches high. Switches for novice/expert setting and game selection. Check your skill on performance rating chart. On-screen scoring, with realistic sound effects.

CONTROLS: Waffled twist-grip throttle controls on console (for 1 player). Four remote controls with 68-in. cords plug into rear of console for paddle games.

INSTALLATION: Use with any TV. Attach game switch to TV antenna terminals, plug in console, tune to channel 3. Operates on 9 v. power supply with 16-ft. cord (incl.). In color on color TV.

ORDERING INFORMATION: Instructions, game rules included. See Warranty below.

- 6 C 99729—Shipping weight 6 pounds 5 ounces \$34.95
 Antenna Switch. Use with any TV to eliminate hook-up to antenna using Tele-Game on second set.
 6 C 99898—Shipping weight 6 ounces \$9.95

FULL 90-DAY WARRANTY ON ALL TELE-GAMES® ELECTRONIC GAMES

For 90 days from purchase date, Sears will repair Tele-Games® electronic games free of charge if defective in materials or workmanship. To obtain warranty service, return to any Sears store throughout the United States. This warranty gives you specific legal rights, and you may also have other rights which vary from state to state.

Cut \$10 to \$29



Your Choice \$15⁹⁹



Your Choice \$12⁹⁹



Your Choice \$19⁹⁹



Storage Systems

(A) The Storage Center holds all video game systems but Atari 5200 and Odyssey. Under the attractive smoked dust cover sits the console, controls, game manuals, even some extra accessories such as the IntelliVoice or the Atan Adapter for the ColecoVision. Roomy storage in back for 18 to 24 cartridges. Plastic with woodgrain cabinetry. 20x16x9 in. high. Console and cartridges not included.
49 C 75484—Shipping weight 5 lbs. 8 oz. \$24.99

(B) 24-cartridge Cabinet. Holds any video game cartridges, instruction manuals or controller overlays, except those for the Atari 5200 system. Attractive plastic dust cover flips up and down. Particle board with woodgrain finish. 13 1/4 x 6 x 9 1/2 in. high.
49 C 75483—Shipping weight 2 lbs. 10 oz. \$19.99

(C) 14-cartridge Cabinet. Holds video game cartridges and instruction manuals for Atari 2600, Coleco Gemini or ColecoVision systems only. Plastic with woodgrain finish. 9x4x10 inches high.
49 C 75486—Shipping weight 1 lb. 5 oz. \$9.99

(D) Storage Cubes. Holds video game cartridges for Atari 2600, Coleco Gemini or ColecoVision systems only. Each interlocking module stores 4 cartridges. Box of 2 cubes. Plastic with woodgrain finish. 4 1/4 x 3 x 4 1/4 in. ea.
49 C 75485—Shipping weight 1 lb. Box \$5.99



1 VideoSmarts™ turns your TV and VCR into learning tools. Hook-up the computer module featuring 4 colorful answer buttons, pop in the pre-recorded VHS lesson cassette and let the fun begin! Teachin' Teddy™ asks educational questions, waits for youngsters to respond and tells them if their answer was right or wrong. He reinforces correct answers with sound effects and lights. Lessons combine animation, live action and computer graphics to hold your child's interest. "Numbers 1-5/Comparisons" cassette included. Warranted by Connors*. Requires 4 "C" batteries, sold separately on p. 404. TV and VCR not included. For ages 3 years and up. 49 N 17688—Shpg. wt. 2 lbs. 2 oz. . . \$44.99

2 Additional VHS learning cassettes for (1).

Description	Catalog No.
"Colors and Shapes" teaches shape identification and color combinations	49 N 17690
"All About Me" teaches about the 5 senses, self-awareness	49 N 17691
"Letters A to Z" teaches how to recognize letters	49 N 17692
"Numbers 1-20/Comparison" teaches counting, location	49 N 17693
"Letter Sounds" teaches phonics and spelling	49 N 17694
"Nutrition/Health/Safety" teaches good personal habits	49 N 17695

Shpg. wt. each 14 oz. . . Each \$14.99

3 VHS cassette storage/carrying case fits learning cassettes for (1), above. Vinyl. Holds up to 10 cassettes. 49 N 17749—Shpg. wt. 2 lbs. 4 oz. . . \$7.99
*Write for free copy, see p. 371.

4 Teach Me Reader™ features electronic speech synthesis. Place one of 12 specially-designed storybooks over the keyboard and press the dot beneath any word. Teach Me Reader actually says the word or reads back the entire page. Parents guide incl. Warranted by Playskool*. Requires 4 "C" batteries, sold separately on p. 404. For ages 3 to 6 years. 49 N 17936—Shpg. wt. 5 lbs. . . \$69.99



5 Touch & Tell™ teaches colors, shapes and object recognition using picture panels and a friendly game-voice. Warranted by Texas Instruments*. Requires 2 "D" batteries, sold separately on p. 404. For ages 2 to 5 years. 49 N 17801—Shpg. wt. 2 lbs. 9 oz. . . \$33.99



6 thru 11 Additional learning modules for (5) come with picture overlays.

Description	Catalog No.
(6) "Animal Friends" teaches animal names and sounds	49 N 17853
(7) "All About Me" promotes self-awareness	49 N 17855
(8) "Alphabet Fun" identifies the letters of the alphabet	49 N 17849
(9) "The World of Transportation" teaches about travel	49 N 17857
(10) "Number Fun" teaches number values	49 N 17851
(11) "Little Creatures" teaches about nature life	49 N 17859

Shipping weight each 5 oz. . . Each \$13.99

12 Little Maestro™ is the talking toy that introduces youngsters to basic musical concepts of melody and pitch, while the friendly voice offers encouragement. Warranted by Texas Instruments*. Requires 4 "AA" batteries, sold separately on p. 404. For ages 3 to 6 years. 49 N 17600—Shpg. wt. 1 lb. 14 oz. . . \$34.99

In Sears Land, playtime and learning time can be one and the same!

Computer Smarts teaches computer programming, spelling and more!

\$89⁹⁹



7

7 Computer Smarts is the portable teaching computer that you can use with or without your VCR! Without a VCR you can play games like hangman and word scramble on the built-in screen. Hook it up to a VHS VCR and colorful action and lively music teach lessons ("Letter Perfect" and "Language Skills 1" VHS tape included). Requires 4 "C" batteries, sold on p. 406. For ages 6 to 10 years. Warranted by Connor Toy*. 49 N 17975—Wt. 4 lbs. . . \$89.99

8 thru 11 Computer Smarts 40-minute VHS cassettes.

(8) Word Works-Language Smarts I: covers nouns, verbs and sentences for grades 2 and 3. 49 N 17961—Wt. 10 oz. . . \$19.99

(9) Word Play-Language Smarts II: covers pronouns, adjectives and adverbs for grades 2 and 3. 49 N 17962—Wt. 10 oz. . . \$19.99

(10) Sentence Factory-Language Smarts III: covers nouns, verbs and sentences for grades 4 and 5. 49 N 17963—Wt. 10 oz. . . \$19.99

(11) Sentence Sports-Language Smarts IV: covers pronouns, adjectives. For grades 4 and 5. 49 N 17964—Wt. 10 oz. . . \$19.99

12 Learn to type well with Type-right. Even if you have never been near a keyboard before, Type-right can have you typing after a few lessons. Type-right helps you learn the typewriter keyboard and it builds your speed as you learn. Course book and audio cassette instruction help you learn at your own pace. Internal computer keeps track of mistakes and words per minute—monitors your progress and grades speed and accuracy. Requires four "C" batteries, sold separately on facing page. For ages 9 years and up. Warranted by Video Tech*. 49 N 17909—Wt. 1 lb. 11 oz. . . \$44.99

13 Computer Fun™, an oxymoron? Not with this exciting learning tool. Two word voice recognition and high-resolution, animated graphics help teach 12 games. Topics include pre-reading, early math and creative skills. Requires 4 "AA" batteries, sold separately on facing page. For ages 4 to 7 years. Warranted by Texas Instruments*. 49 N 17623—Wt. 2 lbs. 11 oz. . . \$79.99

Teach and enhance typing skills with Type-right™ . . . course book and audio cassette included



12

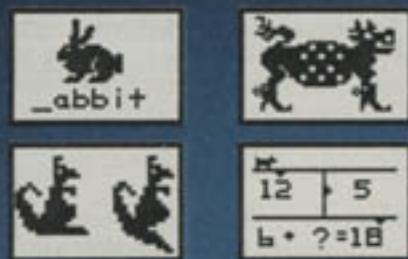

Computer Fun™ features exciting, high-resolution, animated graphics



13

14 A friendly voice encourages children to learn with Speak & Spell™ Spelling drills become lively games and your child will be kept involved in three ways: One, she'll hear the word. Two, she'll press the keys to spell the word. And three, she'll see the word. Over 150 frequently used words. Speak & Spell keeps score. Activity book included. Requires 4 "C" batteries, sold on facing page. For ages 6 years and up. Warranted by Texas Instruments*. 49 N 17807—Wt. 1 lb. 5 oz. . . \$43.99

15 Speak and Read™, the fun way to learn about words! There are more than 250 basic words that are introduced through a friendly electronic voice and fun activities like: "Word Zapper" and "Hear It". "Picture Read" develops vocabulary skills and "Read It" is a fun way to expand reading comprehension and logical thinking. Three levels of difficulty. Activity book included. Requires 4 "C" batteries, sold separately on facing page. For ages 4 to 8 years. Warranted by Texas Instruments*. 49 N 17816—Wt. 2 lbs. . . \$43.99

16 Speak & Math™ may make math your favorite subject! The friendly electronic voice and colorful activity book brings elementary mathematics to life. Over 100,000 random pre-programmed problems. Three challenging levels. Requires 4 "C" batteries, sold on facing page. For ages 5 years and up. Warranted by Texas Instruments*. 49 N 17605—Wt. 1 lb. 6 oz. . . \$43.99

17 Do you remember your first calculator? Well, My First Calculator™ will certainly be remembered by your child. He or she can perform addition, subtraction, multiplication and division. This hand-held unit operates on 1 "AA" battery, sold separately on facing page. For ages 3 years and up. Warranted by Sears*. 49 N 17629—Wt. 8 oz. . . \$9.99

*Write for free copy, see p. 304



Speak & Spell™

Speak & Math™



My First Calculator™ adds, subtracts and divides

17

KEEP IMPORTANT INFORMATION AT YOUR FINGERTIPS!

Compumate organizers help relieve clutter in pocket, desk or briefcase



With electronic speller, telephone directory

1 thru 3 Compumate electronic organizers run on 4 "AA" batteries, not incl. (order on p. 406). Imported. Warranted**.

1 Compumate 1 is a calculator, phone directory and dictionary all in one. Performs standard calculator functions such as addition, subtraction, multiplication and division. Electronic speller is great for writing or for word games and crossword puzzles. Phone directory lets you key in name of person you want to call, then see number displayed. Holds up to 200 numbers. 5.4Lx10Wx1.3D in. 3 E 54166—Wt. 1 lb. 12 oz. . . . \$79.99

2 Compumate 2 has all the features of (1) plus an appointment calendar to help remember important dates, a typing tutor, a security code to help keep your information private and a clock to keep you on time. 7.6Lx10Wx1.3D in. 3 E 54167—Wt. 1 lb. 12 oz. . . . \$99.99

3 Compumate 3 has all the features of (1) and (2) plus a telephone dialer that lets you connect unit to telephone line with modular cord and dial any of your stored numbers automatically. Parallel and serial printer interfaces let you print out hard copy of anything stored in the Compumate through your computer printer. 7.6Lx10Wx1.3D in. 3 E 54168—Wt. 1 lb. 15 oz. . . . \$119.99

AC adapter allows (1 thru 3) to run on 110-120 volts AC. 3 E 54169—Wt. 12 oz. . . . \$12.99

4 Enter a word the way it sounds and the correct spelling is displayed. Built-in 35,000-entry thesaurus gives you a choice of 470,000 synonyms. Shows proper hyphenation. A must for Scrabble®, Hangman, crossword puzzles, etc. 4 1/2x2 1/2x5 1/2 in. Uses 2 "AAA" batteries, not incl. Imported. Warranted**. 3 E 54180—Wt. 8 oz. . . . \$99.99

5 Has the spell-checking capability of 80,000 words, plus a four-function calculator with memory to let you perform complex computations. 4 1/2x2 1/2x5 1/2 in. Uses 2 "AAA" batteries, not incl. Imported. Warranted**. 3 E 54179—Wt. 8 oz. . . . \$79.99

6 Digital diary stores daily appointments in 200-year full-month calendar, plus telephone numbers, addresses, important memos and reminders. All are easy to read on the liquid crystal display. Hard plastic case helps it travel well in pocket or briefcase. Has memory capacity of 31,902 characters. 5x2 1/2 in. when closed. Requires 3 lithium batteries, incl. Imported. Warranted**. 3 E 58335—Wt. 6 oz. . . . \$99.99

**Warranted by Sears or manufacturer. Write for free copy, see page 304.

2 With appointment calendar, typing tutor, privacy code

\$99.99

3

With telephone dialer, parallel and serial printer interface

\$119.99

Franklin pocket spellers for anyone who works with words

Low \$79.99 as

Both feature

- 80,000-word dictionary compiled by Merriam-Webster™
- Quick solutions to word games and puzzles
- Clear LCD display
- Ability to correct words entered incorrectly

Pocket Wordmaster™ WM-1200 4

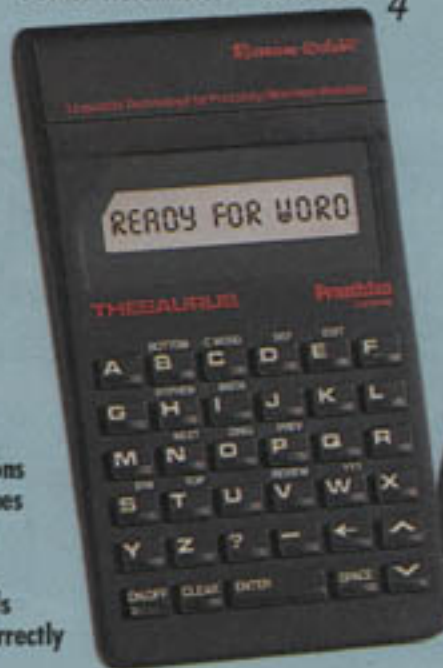

Spellmaster Plus™ SC-120 5



6 Casio® Digital Diary stores appointments, phone numbers, addresses, reminders and more \$99.99

1988 Wish Book Cover Contest Winners
Thomas Olson (age 5), Sparta, WI
Natalee Tritt (age 6), Kenosha, WI
Michael McGuinness (age 10), Williams Bay, WI

Video Game Cartridges for

ATARI | GEMINI | SEARS

2600 by Coleco Video Arcade I and II



Your Choice
\$5.99



Your Choice
\$9.99

(1 thru 22) All cartridges are Sears Tele-Games and have full 90-day warranty, see below. Most cartridges are reduced from our 1983 Spring Big Book, pages 682 and 683. Outer Space (14) and Chase (16) are reduced from our 1980 Spring Big Bk., p. 1141.

HURRY... LAST DATE TO ORDER THESE CARTRIDGES IS DEC. 31, 1983.

Cartridge name and description	Catalog Number
(1) Missile Command. Defend cities from aliens with antiballistic missiles. 1 or 2 players.	49 C 75166
(2) Yars' Revenge. Shatter galactic people's defense shield with atomic cannon. 1 or 2 players.	49 C 75167
(3) Berzerk. Zap evil Oscar's robot minions in a room to room search. 1 or 2 players.	49 C 75168
(4) Arcade Pinball. Pinball to challenge any wizard. Nudge but don't tilt! 1 or 2 players.	49 C 75161
(5) Stellar Track. Search out and destroy enemy ships before your fuel runs out. 1 player.	49 C 75159
(6) Submarine Commander. Find enemy ships with radar and sonar... torpedoes away! 1 player.	49 C 75142
(7) Warlords. Protect your castle and king but attack your opponents' castle. 1 to 4 players.	49 C 75127
Shipping weight 4 oz. Was \$27.99; Now \$15.99	
(8) Demons to Diamonds. Stay clear of the hot rocks that can blow you skyward. 1 player.	49 C 75140
(9) Haunted House. Find the magic urn in a house full of creepy crawlies. 1 player.	49 C 75141
Shipping weight 4 ounces. Was \$24.99; Now \$12.99	
(10) Asteroids. Clear the way for your ship in a deadly asteroid belt. 1 player.	49 C 75163
(11) Defender. Save your friends. 1 or 2 players.	49 C 75186
(12) Race. Includes driving controls. 1 or 2 players.	49 C 75182
(13) Star Raiders. Defend space stations, check chart, hyperspace to combat area. 1 player.	49 C 75187
Wt. 4 oz.; (12) weighs 14 oz. Was \$29.99 to \$37.99; Now \$19.99	
(14) Outer Space. Fly thru star-studded space trying to draw opponent into laser-range. 1 to 2 players.	49 C 75601
(15) Pong. 50 Olympic games in all. Up to 4 players.	49 C 75104
(16) Chase. Force opponent to steer thru course you try. 1 or 2 players.	49 C 75105
(17) Breakaway IV. Smash thru wall. 1 to 4 players.	49 C 75107
(18) Steeplechase. They're off! Up to 4 players.	49 C 75126
(19) Night Driver. Drive down a dark, winding road. Watch out for sudden obstacles. 1 player.	49 C 75119
(20) Dodger Cars. Avoid crashes while eliminating scoring stripes. 1 or 2 players.	49 C 75158
Shipping weight 4 oz. Was \$19.95 to \$34.99; Now \$5.99	
(21) Tank-Plus. Tank battle or aerial dogfights. 1 or 2 players.	49 C 75124
(22) Math Gran Prix. Beat your opponent's car against calculating obstacles. 1 or 2 players.	49 C 75128
Shipping weight 4 oz. Was \$19.99; Now \$9.99	

FULL 90-DAY WARRANTY ON ELECTRONIC GAMES: For 90 days from date of purchase, Sears will repair or replace electronic games free of charge, if defective in material or workmanship. For warranty service, simply return to any Sears store thruout the U.S. This warranty gives you specific legal rights and you may have other rights which vary from state to state.

Organize your complete system or just your cartridges

(E) Game System Storage Cart has roll-top cover and cane-lock cabinet door with magnetic latch. Holds all video game systems. Console sits on top with easy-roll cover. Cartridges and manuals store below behind drop-front door. Storage for controls and power converter in back with cord wrap-ups. Easy-roll, heavy-duty casters. Particleboard with walnut finish. 20½x15½x21½ inches high. Sent partly assembled; instructions and hardware included. Console and cartridges not included. Shipping weight 26 lbs.
49 C 75495C\$59.99

(F) Video Game Cart holds any system but Atari 5200 and Odyssey. Attractive oak-grained vinyl wrapped round fiberboard. Easy-roll, heavy-duty casters. 20x12x20 inches high. Sent unassembled; instructions and hardware included.
49 C 75492C—Shipping weight 5 lbs. 8 oz.\$24.99

(G) Handsome Hassock holds all systems except the Atari 5200 and Odyssey. Removable inside tray holds console, accessories and booklets; bottom holds up to 60 cartridges. Particleboard covered with woodgrain vinyl. Top is padded with polyurethane foam and covered with vinyl. 17½x17½x17 inches high. Sent assembled; just attach casters. Deluxe barrel casters and instructions included.
49 C 75497L—Shipping weight 30 lbs.\$49.99



999.99 No money down
\$50 a month*
Save \$150. GE portable VCR

D Dockable combination portable/home VHS VCR gives you the best of both worlds! Recorder section disengages from tuner/timer for use outdoors (with optional camera), slides back in for use at home. Great fun for the whole family!

4 heads allow for great functions such as Variable Slow Motion, Video Scan (forward and reverse) high-speed scanning and Freeze Frame/Frame Advance for frame-by-frame viewing.

17-function wireless remote control performs Slow Motion, Scan, Freeze Frame/Frame Advance, Record, Play, Rewind/Stop/Fast-Forward, Channel Up and Down, Mode (VCR/TV) and Power On/Off.

8-event/14-day automatic timer allows you to record as many as 8 different programs on any channel (or different channels) up to 14 days in advance. Timer has 8 separate electronic timers. 8-hour capability (depending on tape speed).

Stereo/Dolby noise reduction sound system lets you dub a stereo soundtrack using your Hi-Fi system. Soft-touch electronic tuning lets you change channels randomly/directly or by scanning through them.

Lighted digital channel readout. Direct camera jack. UL listed. Made in Japan. Manufacturer's Warranty.** Was 1,149.99 in our '84 Fall Big Book, page 683.

63 G 79064 MS—Ship. wt. 17 lbs. now 999.99

899.99 No money down
\$45 a month*
Save \$100. GE video camera

E GE deluxe color video camera lets you film your own "movies" indoors or outdoors. Has adjustable electronic Viewfinder—a built-in 1-inch black/white monitor that allows you to see what you're filming. Automatic Dater/Title incorporates an electronic clock and calendar to date tape or to subtitle tape by simply pressing buttons under the concealed door. Also has stop watch feature!

Auto Focus employs an infrared beam to focus lens automatically. 8:1 Zoom Lens for close-ups and wide angles with the touch of a button. 1/2-in. Newvicon tube for excellent low light capability. Auto/manual Iris-control adjusts. Fade in/out control. Focus in/out control. Stereo microphone. Manufacturer's Warranty.** Was 999.99 in our '84 Fall Big Book, page 683.

63 G 79164 MS—Ship. wt. 8 lbs. now 899.99



Includes 17-function wireless remote control with Slow Motion, Scan and Freeze Frame



Recorder section disengages for use outdoors!



Save \$100 **649.99** No money down
\$33 a month*
GE portable VHS video cassette recorder

F Easy-to-handle, simple-to-operate portable VCR from GE lets you become a videotape expert! Lightweight recorder is easy to use outdoors or at home. Enjoy up to 8 hours of recording/playback time. 1-event/24-hour automatic timer allows unattended recording for recording any program while you're asleep, away from home, or watching another program on another channel.

Audio dubbing capacity lets you add soundtracks to your tape. Soft-touch electronic tuning is fingertip-easy! Lighted digital electronic clock/timer. Lighted channel indicators. Direct camera jack.

Still Frame/Frame Advance lets you "freeze" the action, then get a detailed frame-by-frame look. Great for baseball replays and checking your golf swing.

5-power capability: internal battery pack, plug-in AC adapter, vehicle cord, quick-charge adapter (all not included), or use the tuner power supply (included). Made in Japan. UL listed. Manufacturer's Warranty.** Was 749.99 in our '84 Fall Big Book, page 682.

63 G 79054 MS—Ship. wt. 14 lbs. now 649.99

Save \$150 **499.99**
GE color video camera

G No money down. \$25 a month! GE lightweight, compact, portable color video camera brings good things to life! Power Zoom for tight close-ups and wide angles. 1/2-in. Newvicon tube provides greater light sensitivity. Viewfinder is also a monitor that lets you see what you're filming. Also allows in-camera playback using portable deck and earphone (earphone is not included). Manual focus. Macro focus for shooting tiny objects. Fade in/out control. Automatic white balance adjusts to color temperature levels for optimum color reproduction. Stand-by power switch. Built-in microphone. Manufacturer's Warranty.** Was 649.99 in our '84 Fall Big Book, page 682.

63 G 79154 MS—Ship. wt. 29 lbs. now 499.99

RCA Studio II Home TV Programmer

a great gift value

BECAUSE

- It has 5 fascinating games built in, and accepts optional cartridges for more!
- Digital-entry keyboard allows numerical games *and* action games
- Plays your skill against another person, or against the advanced-design computer

AND PRICED AT ONLY

139⁹⁵

or \$7 monthly—see page 341 for full credit terms

Enjoy action-packed video entertainment with Studio II from RCA. Have fun testing your skill with another player or solo against the electronic "brain". It's versatile! Instead of using a limited-function circuit chip, Studio II has a microprocessor (a miniaturized computer) which can be programmed. Five programs are already built in—exciting auto racing with Freeway, math quiz game Addition, sport competition with Bowling, Patterns for programming electronic designs, and Doodles to display your creativity. Optional cartridges provide your choice of additional programs for entertaining variety; order below. Phone-type keyboards for two players control game action with advanced-design solid state circuitry. Sound speaker system built in. Convenient switchbox for selecting Studio II or normal TV operation, easily connects to antenna terminal. 18-ft. wire from Studio II plugs into switchbox. Pilot light shows "on". Well-styled, durable plastic case complements room decor. Works with color or black-and-white TV's—any size. TV set not incl. 110-120V, AC. UL listed. Warranted by manufacturer, see page 336. X 917-2255 A—Mailing weight 4.30 lbs. 139.95

Extra Game Cartridges for Studio II. Programmed circuit provides a completely different video game. Expands your choice of entertainment. Just place cartridge in console slot.

Tennis/Squash—3 ball speeds, 3 racket sizes for each player. X 917-2420 A—Mailing weight 0.25 lb. 14.95

School House—quizzes in history, geography, and math. X 917-2289 A—Mailing weight 0.25 lb. 19.95

Baseball—pitch, bat, field, run bases. For 2 players. X 917-2305 A—Mailing weight 0.25 lb. 19.95

Space War—two exciting "shoot-em-down" games. X 917-2263 A—Mailing weight 0.25 lb. 14.95

Fun with Numbers—three games that test your sharpness. X 917-2271 A—Mailing weight 0.25 lb. 14.95

Blackjack—1 or 2 players try to beat the house; casino rules. X 917-2297 A—Mailing weight 0.25 lb. 19.95

Math Fun—add, subtract, multiply, divide—4 skill levels. X 917-2412 A—Mailing weight 0.25 lb. 19.95



Has 5 Built-in Games

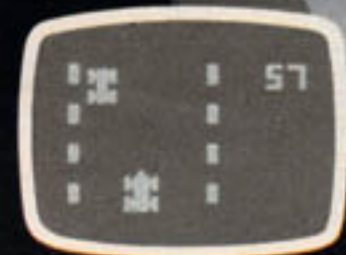

Freeway



Addition

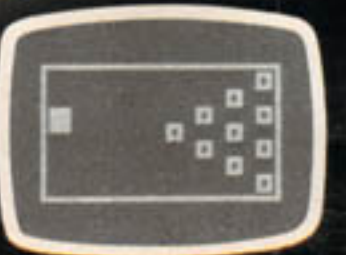

Bowling



Patterns

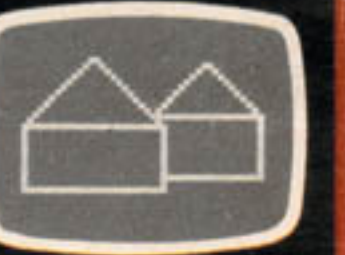

Doodles

It's a computerized bridge club in a box!

Built-in computer is so powerful it lets this electronic marvel play bridge as your partner, your opponents or both . . . or you can watch how the game "outsmarts" itself in fully automatic play

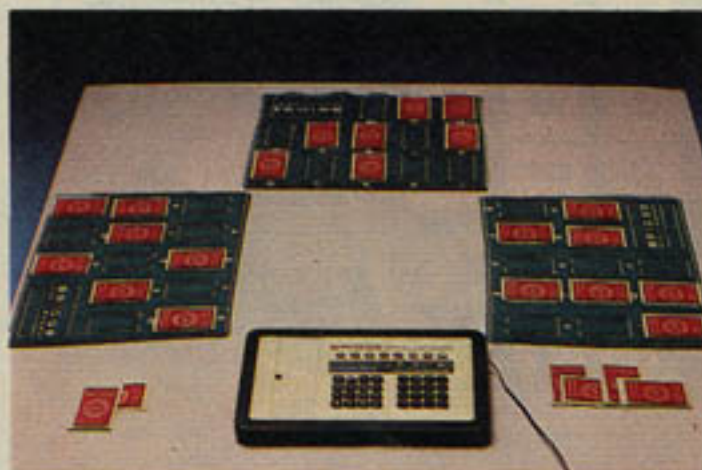

As each computerized player asks to see its hand, pass its cards—face down, one at a time—over the optical scanner and then place them in order on one of the three green felt playing fields provided.

In this manner, "everyone" sees only his own cards.

Need a fourth for bridge? Or a second, third and fourth? Or would you rather watch while four "others" play? Bridge Challenger® is always ready for a game, whether you're short a player or your bridge club is curious to see how a computer would have played their hands. Just tell the machine which positions to play (N, E, S, W), then deal out the custom cards as you normally would.

STAYMAN, GERBER AND BLACKWOOD PLUS SIX OTHERS



Bridge Challenger® automatically uses Stayman, Gerber and Blackwood. Assign each pair of partners one of the six additional conventions or variants that the machine knows: Preferred Minor, Strong Two Club and Weak One No-trump Openers, Jacoby Transfers, the Baron Convention and the possibility of specifying the strength of the 2NT reply following a suit opener. Follow your favorite conventions while entering your bids; the machine will automatically display its own bids on its turns, using the convention you selected for it. When bidding is completed, the screen displays the contract and play begins.



COMPUTERIZED DUPLICATE PLAY

Completing the contract does not have to end play. You also have the option to replay the hand. Just designate any new combination of human and machine players for full duplicate play. And if you wonder how the computer would have done if it had bid "three no trump" instead of "two spades," just override the electronic player's bid and substitute your own.

Bridge Challenger's 176,512 memory bits allow popular defensive play, finesse and squeezes. It rejects illegal bids, displays reneges, lets you review bidding (and the last trick played) and indicates vulnerability . . . all instantaneously.

100% solid state with solid hardwood housing 13 1/8 x 8 1/2 x 1 1/8 in. high. Comes with 2 decks of custom playing cards, carrying case, 9 volt adapter and 6-ft. cord for use with 110-v., 60-Hz. AC.

AGES: Adult. 1 or more players.

ORDERING INFO: Order extra custom cards below.
3 C 2834—Shpg. wt. 4 lbs. \$297.99

Custom Playing Cards for above (not shown).
3 C 28149—Shpg. wt. 4 oz. \$3.99

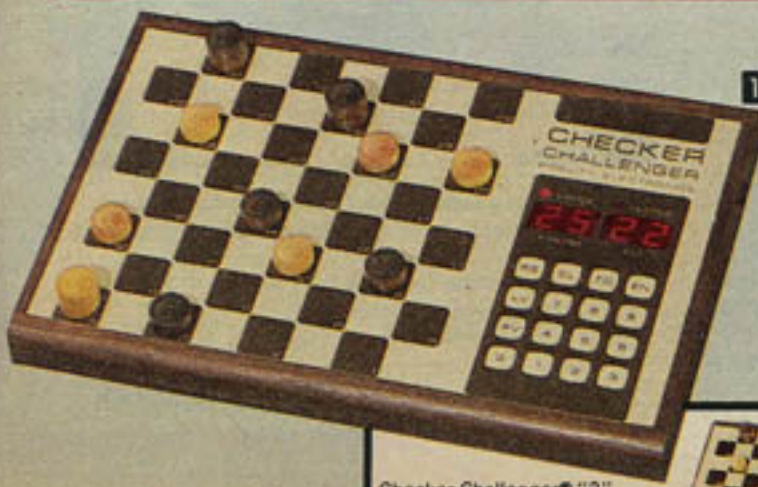

1 Checker Challenger® "4" Lets you choose from 4 levels of difficulty

\$119.99

2 Checker Challenger® "2" Lets you choose from 2 levels of difficulty

\$48.99



(1 and 2) Checker Challenger® Games

KEYBOARD, PLAYING BOARD: DuPont Mylar® polyester film-covered face incorporates playing area, keyboard, 1/2-in. LED display. *Reset* key starts game or cancels computer memory. *Enter* key enters your move into computer. *Clear* key clears unwanted move if Enter has not been pressed or recalls computers' last move. Press *To* key for moving a piece or to set up special checker problems. *Level* key determines level of play. *Position Verification* key verifies position of each piece. The "I lose" signal lights when computer admits defeat. The "I win" signal lights when computer has won. PIECES: Stackable solid wood checker pieces, walnut or maple finish. ELEC. INFO: 6-foot cord with switch. 120-volt, 60-Hertz AC. UL listed.

(1) Checker Challenger® "4". Four levels of difficulty. Problem mode solves classic problems. Recall lets you compare computers' moves. HOUSING: Solid walnut case measuring 12 1/2 x 8 x 1 1/4 inches high. ORDERING INFORMATION: Warranted by Fidelity Electronics, Ltd. Write for free copy, see page 322.
3 C 2961—Shipping weight 3 pounds 3 ounces \$119.99

(2) Checker Challenger® "2". Two levels of difficulty. HOUSING: Simulated wood-grained plastic housing. 12 1/2 x 8 x 1 inch high. ORDERING INFORMATION: Warranted by Fidelity Electronics, Ltd. Write for free copy, see page 322.
3 C 2960—Shipping weight 2 pounds \$48.99

TWO BIG NAMES

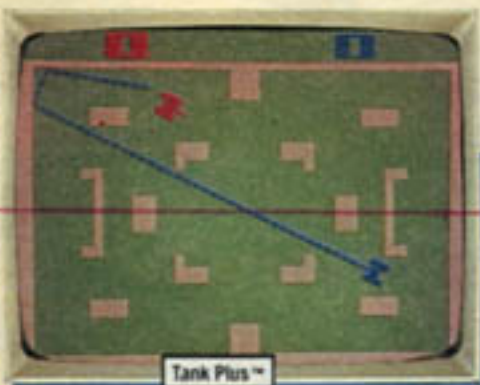

Tank Plus™

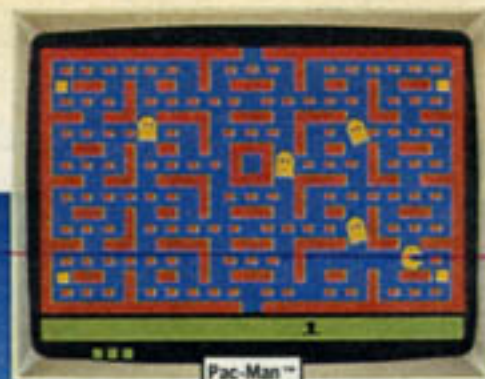

Pac-Man™



ATARI® 2600 VCS
Comes complete with two self-centering joysticks, plus BOTH game cartridges shown above

\$30 REBATE
from Atari
\$89.99 full price | **\$59.99** after rebate

Plays the world's largest cartridge library. Plugs into any color or black and white TV. Easy-access novice/expert, game select, and reset console switches. Warranted by Atari; to write for free copy, see page 323. 13 1/2 x 9 1/2-in. wide console with hand-held controls. UL listed for 110-120-volt, 60-Hz., AC. See page 545 for details on Atari rebate.
49 C 75013—Shpg. wt. 6 lbs. ... Full price \$89.99
Set of 2 Paddle Controls
49 C 75401—Shipping weight 7 oz. ... Set \$14.99
49 C 75455—AC Adapter. Wt. 9 oz. 6.99

Our newest 2600 VCS Compatible Cartridges

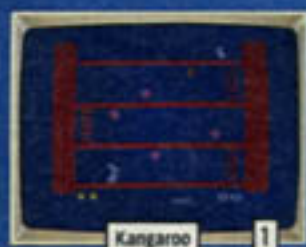

Kangaroo 1



Q*bert 2



Donkey Kong Jr. 3



Popeye 4



Mr. Do! 5



Moonsweeper 6



SeaQuest 7



Return of the Jedi 8



Reactor 9



G.I. Joe 10



The Activision Decathlon 11



Robot Tank 12



Burger Time 13



Dolphin 14

1 or 2 players unless otherwise stated. Warranted by manufacturer; see page 323. Shipping weight 4 oz. each.

Cartridge name and description	Catalog Number	Price
(1) Kangaroo by Atari. Save kidnapped Baby from apple-throwing monkeys	49 C 75173	\$34.99
(2) Q*bert™ by Parker Bros. Bouncing from cube to cube, avoid other loony characters	49 C 75520	34.99
(3) Donkey Kong Jr.™ by Coleco. Perform new, more difficult feats to save Papa	49 C 75556	29.99
(4) Popeye® by Parker Bros. The seaman guips spinach to defeat Brutus and save Olive Oyl	49 C 75521	34.99
(5) Mr. Do! by Coleco. Harvesting this orchard will drive you buggy!	49 C 75554	32.99
(6) Moonsweeper™ by Imagic.™ Rescue moon miners while meteors shower past. Enemy craft swarming in to starboard!	49 C 75359	27.99
(7) SeaQuest™ by Activision. Deep double-trouble; sharks below, pirates at the surface	49 C 75070	27.99
(8) Star Wars: Return of the Jedi® by Parker Bros. Battle defending Tie-fighters to attack Death Star	49 C 75513	32.99
(9) Reactor™ by Parker Bros. Blast the rods before meltdown	49 C 75522	29.99
(10) G.I. Joe™ by Parker Bros. Defend or attack camp. 1 to 3 players	49 C 75514	29.99
(11) The Activision Decathlon™. 8 timed Olympic events. Control speed, height and strength to win	49 C 75076	29.99
(12) Robot Tank™ by Activision. Seek and destroy enemy armor thru different terrains, weather conditions, night or day	49 C 75075	29.99
(13) Burger Time™ by Mattel® Electronics. Build a burger, staying clear of other inedible main courses	49 C 75659	34.99
(14) Dolphin™ by Activision. Tide has turned and the sea monster is closer. Listen for hidden clues to escape	49 C 75073	27.99

*TM of Lucasfilm Inc.



"Move queen to d1 from d5"

"Check and mate"

Our finest Chess Game actually talks to you
 . . . and it responds twice as fast as any we've ever sold

- Provides infinite levels of play. It will continue to search for the best move 'til you press "halt"
- Voice tells you every move and capture . . . and it will repeat board positions on command

\$294⁹⁹

(1 thru 3) Chess Challengers®

KEYBOARD, PLAYING BOARD: *Reset* key starts game or cancels computer memory of game. Depress *Enter* key to register your move with computer. Press *Position Verification* key to verify the position of each piece by rank and file. Use *Double-move* key when you make multiple moves. The *Clear* key erases unwanted moves if *Enter* has not been pressed. Press *Level* key, at anytime during game, for level of playing difficulty desired. *Problem Mode* key used when you want computer to solve specific chess problems, like "Checkmate in 2". Signal for "Check" lights up when the computer has you in check. The "I lose" signal lights up when the computer is checkmated.

PIECES: Magnetic. Staunton design. (1) and (2) have genuine wood pieces, (3) has plastic pieces. King: 2¼ inches high. Imported.

ELECTRICAL INFORMATION: 6-foot cord with switch. 120-volt, 60-Hertz AC. UL listed. 100% solid state.

(1) **Voice Chess Challenger®.** The highest level of playing ability of any chess game we sell . . . an infinite number of difficulty levels. Re-computes its move to respond at different levels of playing difficulty . . . will continue to re-compute move until player presses the "halt" key. Voice feature tells you each move and capture and repeats position on demand . . . can be used by the blind or used to record game play with recorder. Displays the number of moves played at end of game. Deluxe playing surface with raised keyboard.

HOUSING: Solid hardwood carrying case measures 13x8x1½ in.
ORDERING INFORMATION: Warranted by Fidelity Electronics, Limited. Write for free copy, see page 322.
 3 C 2864—Shipping weight 4 pounds \$294.99

(2) **Chess Challenger® "10".** Ten levels of playing difficulty from beginner to expert, including "Mate in Two" and "Chess by Mail". Plays opening defenses from classic chess books. Tone response signals every time you press a key and when computer responds. Override key lets you make multiple moves before computer responds. Simulated leather and brushed gold-color foil playing surface.

HOUSING: Solid walnut carrying case measures 13x8x1½ in.
ORDERING INFORMATION: Warranted by Fidelity Electronics, Limited. Write for free copy, see page 322.
 3 C 2892—Shipping weight 6 pounds \$199.99

(3) **Chess Challenger® "7".** Seven levels of playing difficulty from beginner to expert, including "Mate in Two", "Chess by Mail". Play against computer or watch computer play itself. Change sides on any move in mid-game. DuPont Mylar® polyester film playing surface.

HOUSING: Simulated wood-grained housing, 12¼x8x1 inch high.
ORDERING INFORMATION: Warranted by Fidelity Electronics, Limited. Write for free copy, see page 322.
 3 C 2873—Shipping weight 2 pounds \$94.99



CHESS CHALLENGER® "10"

\$199⁹⁹



CHESS CHALLENGER® "7"

\$94⁹⁹

FAMILY GAME CENTER

INTELLIVISION *Entertainment Computer System*

Now you can make it smarter,
more programmable
and musically inclined

Your Choice **\$99.99**



Includes Burger Time

Intellivision II Master Component

You get more than just a game console — includes Intellivoice (A) on facing page, plus Burger Time cartridge, all for one low price



Computer Adapter

Add-on intelligence — 2K RAM (expandable to 16K RAM) enhances graphic manipulation, sound capabilities plus the BASIC computer language is built right in

Typewriter Keyboard

Now, program all that added-on intelligence to function like a home computer. This keyboard included with the adapter



Music Synthesizer

Not just a toy — play 6-note polyphonic chords on a 49-key, full-size keyboard!

Mattel's Intellivision® has taken on some very unique functions; family education BASIC computing and music. It all starts with the same advanced console that wowed the world but in a smaller, lighter, updated package: The Intellivision II Master Component. With it you play the same exciting games as with its predecessor, Intellivision I, but with these convenient refinements. Controllers are now completely detachable for easy replacement and have longer cords. And there's just one on/off/reset switch with indicator light on the console. The peripherals attach to either console so whether you own Intellivision I or II or Sears Super Video Arcade, you can still create a complete entertainment environment.

Put more intelligence at your fingertips

The computer adapter (2) expands the memory and sound capabilities of the master component. Attach the 16K RAM (random access memory) Expander (sold separately) and its capabilities shoot up to that of a home computer. Then the 49-digit keyboard, included with (2), expands your manipulation of this intelligence. Now you have a full-time, one-to-one tutor. Learn the BASIC computer language that's built right into the system. Then go to other educational programs.

Audio/Video Melody Maker lets you play 6-note chords!

Together with the master component (1) and the computer adapter (2), the music keyboard (3) becomes a 6-note polyphonic synthesizer. Learn to read music even store your own compositions in the memory to play back later.

- (1) Intellivision II Master Component. Includes Burger Time cartridge and Intellivoice™ (A) on facing page. Attaches to color TVs only. UL listed for 110-120 volts, 60 Hz., AC. Warranted by Mattel, see page 323. Plastic, only 12x8 inches wide. 49 C 75024—Shipping weight 5 pounds.....\$99.99
- (2) Computer Adapter/Typewriter Keyboard. Warranted by Mattel, see page 323. 49 C 75033—Shipping weight 1 pound 8 ounces.....\$99.99
49 C 75034—16K RAM Memory Expander for (2). Shipping weight 8 oz. . 79.99
- (3) Music Synthesizer. Warranted by Mattel, see page 323. 49 C 75035—Shipping weight 1 pound 8 ounces.....\$99.99

(4 thru 17) When necessary, each cartridge includes two keypad overlays that customize your hand-held controls. Four new at Sears cartridges. Warranted by manufacturer, see page 323. Shipping weight 4 ounces each.

Cartridge name and description	Catalog Number	Price
(4) O*bert™ by Parker Bros. Quickly bounce from cube to cube, avoiding a cast of queer characters. 1 player.....	49 C 75616	\$36.99
(5) Frogger™ by Parker Bros. Your frantic frog is as jumpy as ever about crossing 4 lanes of rush-hour traffic. 1 player.....	49 C 75615	34.99
(6) Popeye™ by Parker Bros. The sailorman gulps spinach to defeat Brutus and save Olive Oyl.	49 C 75617	36.99
(7) Burger Time™ indigestible by Mattel Electronics. Assemble burger ingredients while avoiding other courses. 1 player.....	49 C 75245	36.99
(8) Loco Motion™ by Mattel Electronics. A crazy scramble to move track blocks to pick up waiting passengers. 1 player.....	49 C 75246	3.99
(9) Donkey Kong™ by Coleco. Your man jumps barrels, climbs ladders, avoids fireballs to rescue his girl. 1 player.....	49 C 75580	34.99
(10) Dragonfire™ by Imagic. Sneak over drawbridge to castle. Once inside, duck and dodge dragon fire to get treasure. 1 player....	49 C 75756	32.99
(11) Pitfall™ by Activision. Thru jungles and sandy deserts, swing over deadly pits full of tigers and snakes. 1 player.....	49 C 75280	29.99
(12) Star Wars™: The Empire Strikes Back by Parker Bros. May the Force be with you. 1 player.....	49 C 75619	34.99
(13) Demon Attack™ by Imagic. Demons split into 2 when hit. You have to get them all. 1 player.....	49 C 75750	32.99
(14) Atlantis™ by Imagic. Defend the fabled isle against unrelenting enemy air assault. 1 player.....	49 C 75751	32.99
(15) Swords and Serpents™ by Imagic. Fight slithering serpents with your laser sword thru 3 different levels. 1 player.....	49 C 75755	32.99
(16) Dracula™ by Imagic. Bite joggers or sleepers for strength. Bite the dust if you're not back to your crypt by dawn. 1 player.....	49 C 75757	32.99
(17) Nova Blast™ by Imagic. Zap and blast enemy craft. But more keep coming. Refuel and go after them again. 1 player.....	49 C 75759	32.99

If the electronic game you order from this book happens to be on sale in a current book or has a manufacturer's rebate not listed here, we will honor the lower price or send you the rebate information—automatically.



NEW! Disney tape recorder with Mickey Mouse[®] mike

24⁸⁸

Mickey Mouse isn't talking through his hat—you are! When you tape family celebrations everyone has a chance to "speak"—even Rover! You'll find dozens of uses for this fine quality tape recorder—tape get-togethers with family and friends, record club meetings, notes for homework; tape "voice letters"; record favorite music. Also plays any standard cassette. Solid state circuitry for trouble-free operation; single control for rewind, play, stop and fast forward; automatic record level for even recording; volume control adjusts sound level in playback. Easy to operate—just drop cassette tape in place; record interlock control prevents accidental erasing of pre-recorded tapes. Completely portable—runs on four "C" batteries (order on page 369)—or with adapter sold below. Durable high impact plastic; 10 $\frac{1}{2}$ x 5 x 2 $\frac{3}{8}$ in.; carrying strap. Blank cassettes and adapter sold separately below—

or buy combination and save!
From Japan. Ship. wt. 3 lbs. 8 oz.
48 T 20005.....24.88

©Walt Disney Productions



AC Adapter 4⁹⁹

Just plug into wall outlet and recorder runs without draining batteries. 6-ft. long cord. Use with recorder sold above. Ship. wt. 8 oz.

48 T 20006—Adapter for recorder only.....4.99

Cassette tapes 2³⁹

Package of 3 blank cassette tapes fit recorder sold above. Easy to use—just snap into place, hands never touch tape. Keep plenty on hand—be ready for any occasion. Ship. wt. 3 oz.

48 T 20020—Pkg. of 3 tapes.....2.39

SAVE \$2 on combination

SAVE 2.38—buy recorder, adapter above and tapes. (32.26 separately.)

48 T 20007—Ship. wt. 4 lbs. 3 oz.....29.88



Electronic calculator

- 6-digit readout with floating decimal
- Four functions: add, subtract, multiply and divide
- Performs chain and mixed calculation

Only **14⁴⁴**

Raggedy Ann and Andy[®] electronic calculator has numerically sequenced keyboard. Kids learn to work out simple or complex math problems (parents will find uses for it too). High impact plastic; 8x2 $\frac{1}{2}$ in.; fits schoolbag or briefcase. Runs on one 9-volt battery (order on page 369) or AC adapter below.

48 T 20505—Japan. Ship. wt. 8 oz.....14.44

48 T 20004 X—AC adapter. Ship. wt. 8 oz.....4.88

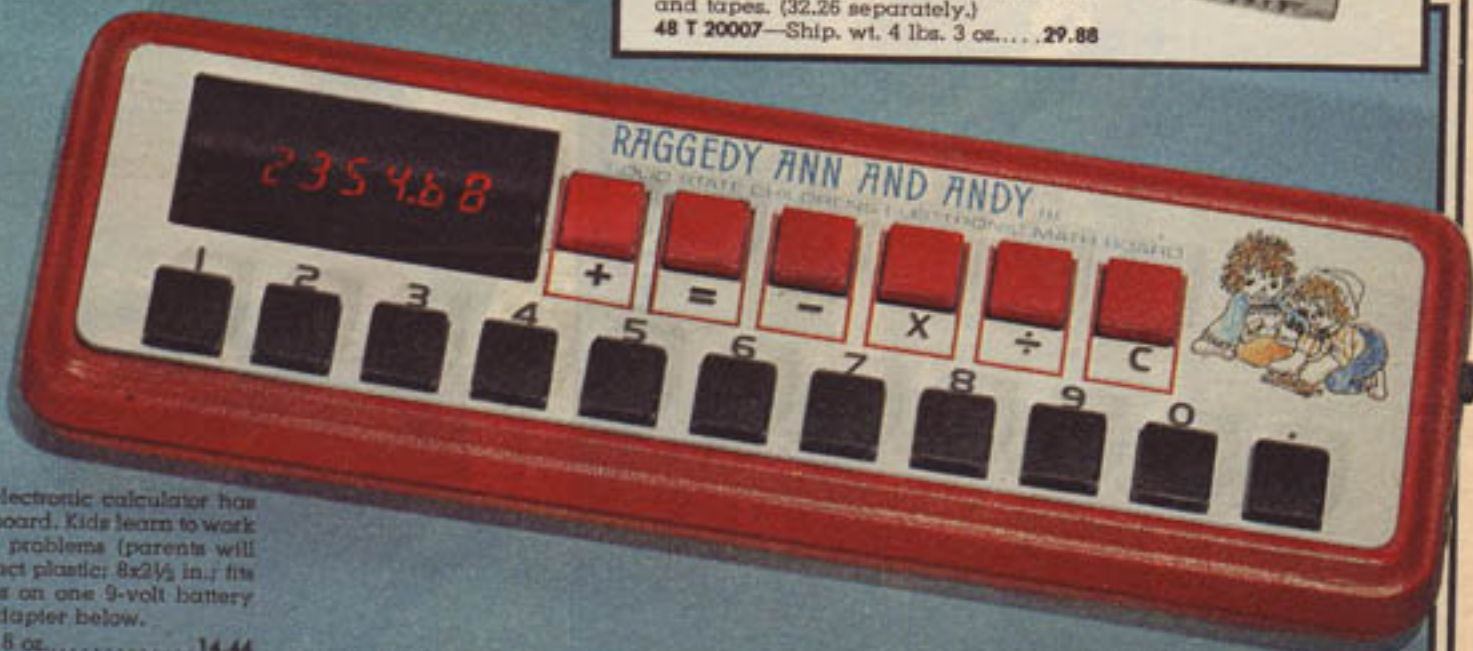

©1974 The Bobbs-Merrill Co. Inc.

SEEK THE UNIQUE



A Write yourself notes, itemize lists, calculations. Sharp EL-7001 MemoWriter prints a full alphabet as well as arithmetic on plain paper tape. 40 independent memories. Basic arithmetic, plus percentages, constant, reciprocal, powers, chain calculations. Floating/fixed decimal. Memory Safe Guard™ saves data in memory even when power is off. Long-life Ni-Cad battery; 115V. AC adaptor/recharger included. Only 7½x3¾x1½ in. Mfr.'s warranty; write for your free copy, see pg. 322. More calculators pgs. 7, 325. 67 T 8701 LS—Ship. wt. 2 lbs. 119.95

B Tomytronic™ Wrist Bowling watch lets you bowl a game with a friend—or alone—any time! Actually keeps score. Also an LCD watch, stopwatch and alarm. Batteries incl. More games on pages 479 to 491. 48 TF 14712—Ship. wt. 7 oz. Until Dec. 1, 29.97
48 T 14712—Ship. wt. 7 oz. After Dec. 1, 34.99

C Sleekly styled pen/watch in red enamel-like material with gold-color metal trim. Pen uses standard Parker refill. LCD digital quartz watch gives hour/min./month-date/seconds. Mfr.'s warranty; write for free copy, see pg. 322. More watches pgs. 108-120. 45 T 755—Ship. wt. 10 oz. 19.95



D Elsi Talking Quartz alarm—the pocket-size marvel has digital LCD readout and speaks to tell you the time—when you press the button, every half-hour, or at pre-set alarm time. Alarm starts with a chime, announces the time, then plays a melody; repeats announcement with "Please hurry" at five and ten minutes after alarm. Also works as a talking elapsed timer and talking stopwatch. Approx. 1-yr. battery incl.; only 4½x3¾x2¾ in. Mfr.'s warranty; write for free copy, see page 322. See more alarms pg. 232, 233. 45 T 9475 LS—Ship. wt. 6 oz. 69.88



Save time at Christmas . . . Home Delivery's fast, easy. See page 322. Buy this truck bank page 23.



et us entertain you

The traveling band of 'bots from the 21st century are ready to fill your Christmas with fun!



1. *Omnibot 2000 can bring you things, pour and serve drinks or serve hors d'oeuvres on his tray. Moving head and flashing eyes add "life." 7 day/24 hour programmable timer/tape memory. Rechargeable 6-volt battery and recharging unit included. 26 inches tall. Warranted*. Wt. 26 lbs. 49 C 54585C...\$449.99*

2. *Maxx Steele is the ULTIMATE in robots. Guide him to bring you a snack, play music, wake you up or play computer games. His 140-word vocabulary makes him quite a conversationalist. He lets you know when he's shutting down to conserve energy and he asks you for a recharge when his battery (included) runs down. Charger included. 24 inches high. Warranted*. See "N" note on page 335. For 8 years and up. 49 C 54581N—Wt. 34 lbs...\$499.99*

3. *Omnibot moves forward and backward, turns right and left, has a manual grasping hand and carries objects on his detachable tray. 7 day/24 hour, timer/tape memory. His eyes light when he talks, he stands 18 in. tall. Built-in rechargeable battery and recharging unit incl. Requires 2 "AA" batteries sold sep. on page 459. Imported. Warranted*. For 11 years and up. Shpg. wt. 10 lbs. 49 C 54582...\$229.99*

4. *Chatbot records and delivers 30 seconds of messages and brings back an answer... all with remote control. 8 1/4 in. high. Requires two 9-volt and two "C" batteries sold sep. on page 459. Warranted*. For 6 years and up. 49 C 54715—Wt. 3 lbs...\$59.99*

*Warranted by manufacturer. Write for free copy, see page 335.





**You're the last one left
to defend the earth...
you'd better fire straight!**

**Electronic space-action game offers
basic and advanced skill levels for
all kinds of excitement!**

\$34⁹⁹



1 You're in the cockpit, ready for action . . . and you've got plenty of enemy spacecraft to face. Space target game features a large, fully electronic liquid crystal display that shows all the action. Firing button on controller gives you attack capabilities, and you'll hear all the action as you fire! Includes score display, On/off switch. Uses 2 "AA" batteries sold on page 406. Plastic. Warranted by manufacturer; write for free copy, see page 304. For ages 5 years and up. 49 N 62679—Wt. 2 lbs . . . \$34.99

2 It's an anti-tank battle with your best weapon. Tank Attack™ electronic battle game lets you play against the computer in a test of skill and nerves. On-screen cross finds the target for your shots. Push-button accelerates game speed and 9 skill levels increase automatically. On/off volume control. Detachable tripod stand is adjustable for playing comfort. Uses 2 "AA" batteries sold on page 406. Plastic. Warranted by manufacturer; write for free copy, see page 304. For ages 5 years and up. 49 N 62710—Wt. 1 lb. 7 oz . . . \$29.99

3 Magic Shot™ arcade recreates carnival fun. Colorful self-contained shooting gallery gives you all the sounds and fun of this carnival favorite. Players take aim at ducks, bottles, clowns and balloons. The highest scorer is the winner. Includes scorers and steel ball-bearing bullets. Plastic. For ages 4 years and up. 49 N 62674—Wt. 2 lbs. 6 oz . . . \$12.99

4 Skittles keeps you on the edge of your seat! Exciting bowling game has a spinning top that ricochets off the walls, darts through openings and knocks down the ten hardwood pins. The one who knocks down the most pins is the winner. Wood construction. For 2 or more players, ages 6 years and up. 49 N 62689—Wt. 7 lbs . . . \$24.99

5 Quick thinking is the key to Head-to-Head™ Perfection®. You have to race against the clock and your opponent as you try to match the shapes on the game board. If you aren't fast enough, all the pieces pop out when the windup clock expires. Plastic. For 2 players, ages 6 years and up. 49 N 62671—Wt. 3 lbs. 6 oz . . . \$19.99

6 All the fish are biting, but be quick . . . you have to catch the fish with your pole before their mouths snap shut. The player with the most fish wins. Uses 1 "D" battery sold on page 406. For 1 to 4 players, ages 5 years and up. 49 N 62792—Wt. 2 lbs. 3 oz . . . \$9.99

7 Where winning or losing hangs in the balance; score points in Topple™ by completing rows and stacking pieces, but don't let it topple down. The more points you score, the harder it is to keep Topple™ balanced! Plastic. Contains board, stand, 40 game pieces, playing die and complete instructions. For 2 to 4 players, ages 6 years and up. 49 N 62698—Wt. 1 lb. 6 oz . . . \$11.99



**Tank Attack™ pits you
against the computer!**

- ◆ Fast-action animated LCD display
- ◆ Realistic sound effects for awesome play



**We'll deliver
right to your
home or office
for just a
little more
than store pick-up
for mailable orders**





5-feature
L.E.D. Watches
by Texas
Instrument
Your Choice

19⁹⁵
each

5-feature
Watches by
Timeband

Accuracy
at the Touch
of a Button
with L. E. D. Digital
Watches

- No moving parts
- Powered by a tiny energy cell (incl.)



Nothing so smart was ever so simple...

TIMEX/Sinclair 2068 Color Computer



SO SMART—its 48K memory will track your family's budget, mortgage payments and tax-deductible items (it sure does beat a calculator on April 15th)

SO SMART—it'll teach your kids (and even you) the basics of communicating with and programming a computer... BASIC language built in

SO SMART—it'll deliver endless hours of fun and dazzling excitement as you work your way thru mind-boggling color games

Last but certainly not least...

SO SIMPLE—you just unpack it (everything's included), hook it up to your TV set and... go to it!

All the computing power you may ever need... all for only **\$179.99**

Designed as a computer first, rather than a video game

(1) It's got 48K of memory power with built-in BASIC programming language, 8 vivid high-resolution colors and 4 simultaneous sounds. It has special features to set it above the competitors. One-Touch Keyword lets you program an entire computer word with a single key. This saves typing time and computer memory as well. Syntax Check and Error Report monitors your instructions and tells you if you've made an error, right away. Many computers let you write a whole program and try to run it before it tells you that an error was made. 64 character display allows you to also use it as a word processor. 42 full-travel keys on a typewriter-like keyboard. Includes AC power adapter, TV switch box, cables for hook-up to TV and any compatible cassette recorder and User Manual. Cassette and Cartridge programs sold below. Warranted by TIMEX Corp. Write for free copy, see p. 323.

3 E 23022C—Shipping weight 3 pounds\$179.99

(2) TIMEX/Sinclair 2040 Printer. Full-scale features at scaled-down price and size. Immediately expands the use of the computer by providing data printouts. It features quiet operation as well as complete graphics and text capability in two screen modes. 32-column width and dot matrix print mechanism. Measures 7 1/4 x 5 1/4 x 3 1/2 inches high. Includes AC power adapter, cable, one roll thermal paper (extra rolls sold below). Warranted by TIMEX Corp. Write for free copy, see page 323.

3 E 23015C—Shipping weight 4 pounds\$99.99

Thermal Printer Paper, Package of 3 rolls. Measures 4 1/4 in. wide.

3 E 23023—Shipping weight 2 poundsPg. \$5.99

Build up a collection of programs for your new TIMEX with all the color and sound you can handle



Pinball™ Just like real pinball with flippers, bumpers, "nudge" and bonus points. Uses fast machine code to choose moves. Shpg. wt. 2 oz. 3E23409—Cs.\$19.99 3E23410—Ct. 29.99

Penetrator™ Fly ship over hills and valleys, thru tunnels to bomb enemy base. 4 levels. Wt. 2 oz. 3E23413—Cs. ...\$19.99 3E23414—Ct. ...\$39.99

Swordfight™ Cut, thrust and parry in a "fight to the death". Instant display to strengthen skills. Wt. 2 oz. 3E23415—Cs. ...\$19.99 3E23416—Ct. ...\$29.99

Casino I™ Try Blackjack or 21, Craps and Slot Machine. Casino rules. Computer deals. Wt. 2 oz. 3E23417—Cs. ...\$15.99 3E23418—Ct. ...\$29.99



Androids™ Fast paced, exciting maze game. Androids on your tail, find the exit fast! Shpg. wt. 2 oz. 3E23411—Cs. ...\$19.99 3E23412—Ct. ... 34.99

Crossfire™ Test your reflexes as you whiz thru menacing maze without getting zapped. 3 E 23419—Shipping weight 2 oz. Cs. ...\$19.99

Circuitboard Scramble™ Have fun while learning about computers. Run friendly "bug" thru the circuit board. 3 E 23420—Shipping weight 2 oz. Cs. ...\$19.99

Dragmaster 2000™ Speed over a 1/4 mile dragstrip. Shift gears, monitor speedometer/tach to achieve best time: Wt. 2 oz. 3 E 23421—Cs. ...\$15.99

Frogger™ Guide your little frog thru traffic and across the river while avoiding slithering snakes and crazy crocodiles. 3 E 23431—Shpg. wt. 2 oz. Cs. ...\$24.95

Guardian™ As guardian of the high seas, "nuke" those awful droid warships. Watch them sink. 3 E 23422—Shpg. wt. 2 oz. Cs. ...\$15.99

Space Robbers™ Tremendous high-speed race to destroy the evil space robbers before they steal your fuel. 3 E 23423—Shpg. wt. 2 oz. Cs. ...\$19.99



Flight Simulator™ Puts you in the pilot's seat. Full controls and instrumentation of light aircraft with horizon view. Shpg. wt. 2 oz. 3E23433—Cs. ...\$24.99 3E23424—Ct. ... 39.99

Chess™ Classic match between you and the computer. 3 E 23432—Shipping weight 2 oz. Cs. ...\$19.99

States and Capitals. Drill yourself on same. Wt. 2 oz. 3E23434—Cs. ...\$15.99 3E23425—Ct. ...\$29.99

Time Teacher I™ Progressive system with a graphic approach to teach children how to tell time. 3 E 23426—Shipping weight 2 oz. Cs. ...\$15.99

Time Teacher II™ Continuation of Time Teacher I 3 E 23427—Shipping weight 2 oz. Cs. ...\$15.99

Spelling I™ Helps develop proficiency in spelling for children grades 3 thru 8. Games, drills and fun activities. 3 E 23428—Shipping weight 2 oz. Cs. ...\$15.99

Spelling II™ Advanced spelling bee. Grade 9 and up. 3 E 23429—Shipping weight 2 oz. Cs. ...\$15.99



Vu-Calc™ Spread-sheet approach to financial and statistical analysis, budget sheets, projections, engineering calculations. Shpg. wt. 2 oz. 3 E 23400—Cs. ...\$24.99 3 E 23401—Ct. ... 34.99

Vu-File™ User-defined formats, index on any field at any time. Fast sort, wild card search, full screen input and edit. Mailing lists. Wt. 2 oz. 3E23402—Cs. ...\$24.99 3E23403—Ct. ...\$34.99

Vu-3D™ Design and modeling program. Create object on screen, then modify, expand shade, color and zoom in/out 3 E 23404—Shipping weight 2 oz. Cs. ...\$24.95

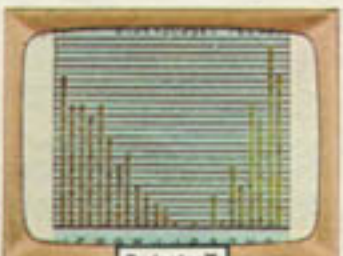

Budgeter™ Track personal budget and expenses in 50 different categories. Can be modified by experienced user. Bar graph. Wt. 2 oz. 3 E 23430—Cs. ...\$24.99 3 E 23405—Ct. ... 34.99

Home Improvement Planner™ Record interior room dimensions to determine cost of painting, wallpapering, carpeting. 3 E 23406—Shipping weight 2 oz. Cs. ...\$19.99

Yard Improvement Planner™ Plan yard care for seeding, fertilization and plant care. U.S. map shows climates. 3 E 23407—Shipping weight 2 oz. Cs. ...\$19.99

Auto Analyzer™ Track routine maintenance/service. Diagnose problems with engine, transmission, front end. 3 E 23408—Shipping weight 2 oz. Cs. ...\$24.95

CUSTOMER NOTE: Cs = Cassette Ct = Cartridge. All programs warranted by TIMEX. Write for free copy, see page 323.

For audio...



For video...

9.99-24.99

Audio and video accessories make great gifts

- A** Cassette storage cabinet with Budweiser label design holds 70 cassettes. Made of 100% kiln dried wood and finished in a beautiful light walnut. Lacquered for protection. Complete with wall hangers, hinged doors with magnetic catches. 15x9x4 inches.
62 G 3440—Ship. wt. 10 lbs. 21.99
- B** Padded vinyl cassette case holds sixty cassettes. Heavy-duty riveted construction. Two-sided access. Brown with decorative stitching.
62 G 3433—Ship. wt. 3 lbs. 12.99
- C** Wooden "crate-look" record rack holds 80 records. Makes a delightful addition to any den or music room. 13½x15x15 in. Shipped unassembled.
62 G 3441—Ship. wt. 11 lbs. 21.99
- D** Wooden cassette box for at-home storage. Holds 16 cassettes. Hinged lid. Beautifully finished in dark oak.
62 G 3432—Ship. wt. 3 lbs. 11.99
- E** Wooden storage drawer holds 33 cassettes. Dark oak finish.
62 G 3431—Ship. wt. 6 lbs. 24.99
- F** Two-drawer cassette tape cabinet holds 28 cassettes. Rich woodgrain finish. Uniquely designed drawers with recessed handles for maximum protection. Four cushioned feet protect surfaces and allow easy stacking.
62 G 3422—Ship. wt. 5 lbs. 5 oz. 13.99
- G** Silver attache cassette holder for a high tech look. Deluxe slimline carry-case holds 30 cassettes. Velour flocked interior.
62 G 3430—Ship. wt. 2 lbs. 9 oz. 17.99
- H** Three-drawer model cassette storage cabinet holds 42 cassettes. Uniquely designed drawers with recessed handles. Woodgrain finished. Cushioned feet protect surfaces and allow easy stacking. Sturdy construction will support cassette deck.
62 G 3421—Ship. wt. 7 lbs. 5 oz. 17.99

- I** Discwasher® tape deck care set includes the Discwasher® Perfect Path cassette head cleaner and the Discwasher® C.P.R. Capstan Pinch Roller Cleaner for careful cleaning and maintenance of your home and car tape decks.
62 G 154—Ship. wt. 6 oz. 12.99
- J** Discwasher® D4 record care system cleans without reduction in record dynamics and fidelity. The combination of the D4 fluid and micro-fibers pad lift dust and other contaminants from the record surface for cleaner records.
62 G 150—Ship. wt. 6 oz. 14.99
- K** Video cassette carrying case holds 6 VHS or Beta video cassettes. Durable construction and richly finished in brown padded vinyl with fully stitched binding and brass plated hardware. Attache style handle for carrying comfort. Molded tray holds cassettes securely.
62 G 3446—Ship. wt. 1 lb. 9.99
- L** Video cassette cabinet has two drawers to hold 24 VHS or Beta video cassettes. Sturdy construction will even support your VCR. Uniquely designed drawers with recessed handles. Rich woodgrain finish. Four cushioned feet protect surfaces and allow for easy stacking.
62 G 3424—Ship. wt. 12 lbs. 5 oz. 24.99
- M** Video game center holds Atari 2600 or 7800, Colecovision, Gemini and Intellivision I and II systems. Includes sectioned compartments for accessories, instructions and games. Woodgrain cabinet. Translucent dust cover.
62 G 3426—Ship. wt. 7 lbs. 4 oz. 19.99
- N** Single drawer video cassette cabinet holds 12 VHS or Beta video cassettes. Rich woodgrain finish. Uniquely designed drawer has recessed handle. Four cushioned feet protect surfaces and allow for easy stacking.
62 G 3445—Ship. wt. 5 oz. 14.99
- O** Video game cartridge organizer holds 24 Atari 2600, Intellivision, Odyssey, Colecovision, and most compatible game cartridges. Holds 16 Atari 5200 cartridges simply by changing dividers. Woodgrain cabinet.
62 G 3427—Ship. wt. 2 lbs. 1 oz. 12.99

Mini Tape Recorder

with built-in condenser mike

**A
Great
Gift
Value**

Shown actual size

NEW FEATURE
review control

BECAUSE it has

- Automatic shutoff
- Dual-power
- Pushbutton recording

AND YOU SAVE \$20.07

39⁸⁸

this special price ends Dec. 25

100% SOLID-STATE AC/DC MINI CASSETTE RECORDER. Automatic volume-level control as you record. Pause control—push to stop recording, release to start again. Review key switches directly from play to rewind—releasing key automatically returns to play. 1½-in. speaker. Earphone. Works on house current or 4 "AA"-cell batteries (batteries not included). Black plastic cabinet with plastic strap. 1½x4½x5½ in. high. Mailable; wt. 1 lb. See warranty on facing page. Reduced from our big Fall '76 Cat.—see p. 716. After Dec. 25, order at regular price. X 851-0265 A.....Reg. \$59.95; NOW 39.88



NEW FEATURE
pause control



3-Speed Stereo/Phono System is a Great Gift Value

BECAUSE it has

- BSR automatic changer
- Two 4-in. speakers
- Full, rich sound

AND YOU SAVE \$10.07

49⁸⁸

this special price ends Dec. 25



3-SPEED AUTOMATIC BSR CHANGER has 7-in. turntable, synthetic sapphire needle. 45-rpm adapter, smoked-plastic dust cover. Rotary dials for volume, balance, tone. Two 4-in. speakers in 14-in. high cabinets—wood-grained vinyl on wood products. Solid-state main unit: 13½x12½x3¾ in. high with 10-ft. connecting cords. Speaker cabinets: 9½x5x14 in. high. 110-120V, AC. UL listed. See warranty at right. Mailable; wt. 25 lbs. Reduced from our big Fall '76 Catalog—see page 717. After December 25, order at regular price. X 853-0420 A.....Reg. \$59.95; NOW 49.88

JCPENNEY FULL 90-DAY WARRANTY
Within 90 days of purchase, we will repair or replace, at our option, this JCPenney Component System or individual component, if defective in material or workmanship. Parts and labor are included. Just return it to JCPenney.



JCPenney 9

Digital audio is awesome

Sound so clear, you can't believe your ears the first time you listen to a disc... or the one thousandth time

You've heard stereo before, but never like this. Treat your ears to music that sounds so real, you might just think it's the original. Our Compact Digital Audio Disc Player (CD) uses a sophisticated laser system to delicately lift the sound off compact discs for phenomenal sound.

No snaps, crackles or pops

Out of the silence comes full, dynamic stereo so clean and clear, it's virtually uncompromised by background noise. In fact, our CD delivers sound with wow and flutter so low, it's undetectable.

It's easy to operate

All you do is push the "open" button and the drawer slides out. Drop in a disc, push the button again to close drawer, hit play and you're ready for great music. You can also program the songs in any order you want.

Great sound for years to come

These discs are practically indestructible. You no longer have to worry about dust and dirt, fingerprints or even warping thanks to their tough plastic coating.

We'll even start your disc library

You'll get Vivaldi's *The Four Seasons*, Handel's *The Water Music* and Tchaikovsky's *Symphony #5* all for only \$10 more



Compact Digital Audio Disc Player **\$589⁹⁹**

You'll enjoy up to 60 minutes of the best sound recordings you've ever heard on just one side of the disc. Since the disc rotates at a rate of 200 to 500 times per minute, we've added a special direct-drive motor that will play your discs at these high speeds. Plugs into stereo's aux. or tape jacks. For all dedicated audiophiles, here are vital specs. Each disc is only 4 1/4 in. in diam. (actual size shown above). The frequency response is 5 Hz. to 20 KHz. Dynamic range, signal to noise ratio and channel separation are 90 dB or more. THD is 0.003% (1 KHz.). Plastic cabinet, only 3 1/2 H x 13 1/4 W x 12 1/2 D in. See Note, p. 409.

57 E 9750C—Shpg. wt. 16 lbs. Compact Disc Player alone **\$589.99**

408 ALL For \$10 more you get 3 discs (mentioned above) with your Player
57 E 97509C—Wt. 17 lbs. Player with 3 discs **\$599.99**

EVERYTHING YOU EVER/NEVER WANTED TO KNOW ABOUT LASERS

A laser sounds boring until you hear it work. The beam from the laser diode (A) is reflected off the beam splitter (B) and focused thru the objective lens (C). This beam reads the musical information pits (D) on each disc and returns once again thru the lens and the beam splitter with the encoded music. This in turn is shot into the photo-detectors (E) and you receive clean, ear-pleasing music.

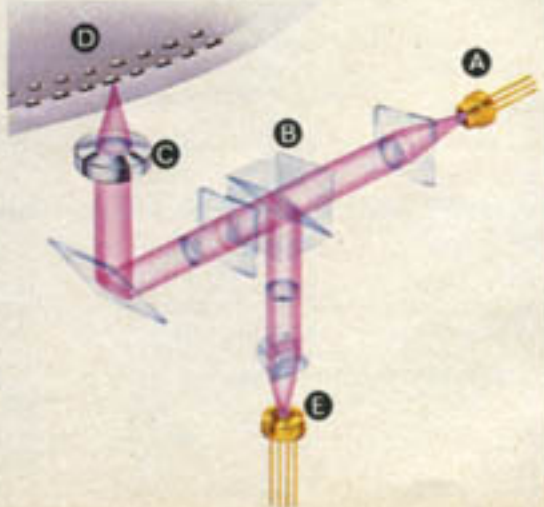



ELECTRONIC LEARNING AIDS

(1) **2-XL™** . . . Mego's talking Robot. Perhaps once in a generation, a new type of family entertainment comes along unlike anything ever seen or heard before. 2-XL has a personality that will both amuse and entertain. Plug cartridge in, press buttons. He asks questions; he tells jokes; he asks riddles; he plays music and sings songs. Most of all, this talking Robot will keep your family laughing, guessing. 2-XL is complete with introductory 8-track tape. $6\frac{1}{4} \times 8\frac{1}{4} \times 11\frac{1}{2}$ in. Plastic. Imported. ELECTRICAL INFO: UL listed transformer. 110-120-v. 60-HZ. AC. 2 w. 6-ft. cord. AGES, ORDERING INFORMATION: 5 years to adult. Instructions included. 49 C 16952—Shipping weight 4 pounds 4 ounces \$51.97

2-XL™ Extra 8-track Tapes for (1).
ORDERING INFORMATION:
49 C 18226—Storyland 49 C 18227—General Information II
49 C 18228—2-XL in Space 49 C 18229—Great People
49 C 1823—Sports 49 C 18231—Metrics
Shipping weight 4 ounces Each \$5.67

(2) **2-XL™ Game** . . . there's always someone to play with when 2-XL's around. 2-XL Robot (not included, order above) plays this game with you. You move his pieces for him according to his responses. Be careful, he changes his strategy based on your moves. Complete with 8-track tape. $8 \times 7\frac{3}{4} \times 1\frac{3}{4}$ in. high. Plastic. AGES, ORDERING INFO: 5 yrs. to adult. Partly assembled, instructions incl. 49 C 18211—Shipping weight 6 ounces \$8.44

(3) **Spelling B™** builds spelling skills
CAPACITY, MEMORY: 8-letter display. Memory stores up to 5 words.
TEACHING FUNCTION: 3 levels of difficulty from grades Kindergarten thru 4. Unit displays number from activity book. Student finds picture, keys spelling onto display. If wrong, student may try again. Correct spelling given after 2 tries. Shows score after each set of 5 words. Book has 264 color pictures of objects to spell.
CONSTR: Yellow plastic. $6\frac{1}{2} \times 4\frac{1}{2} \times 1\frac{1}{16}$ in. Uses one 9-v. battery (order below).
ORDERING INFORMATION: Activity book, case included. Warranted by Texas Instruments. Write for free copy, page 322.
3 C 58097—Shipping weight 1 pound 5 ounces \$29.99

(4) **Speak & Spell™** spelling aid
CAPACITY: 8-letter green-light display.
TEACHING FUNCTION: 4 levels of difficulty for ages 7 and up. Unit pronounces word, student keys in spelling. If correct, student is praised, if not, he is encouraged to try again. Repeats single word or series of 10 words. Score is announced after each 10 words. About 50 words in each level.
CONSTRUCTION: Red plastic. $10 \times 7 \times 1\frac{1}{16}$ in. Uses 4 "C" cell batteries (not included). Order battery packages below.

ORDERING INFORMATION: 32-page illustrated book included. Warranted by Texas Instruments. Write for free copy, page 322. Order extra modules below.
3 C 58098C—Shipping weight 2 pounds \$58.99
DieHard "C" Alkaline Battery for (4). Package of 2.
3 C 8993—Shipping weight 5 ounces Package \$1.39
Vowel Power Module. Helps students in grades 2 thru 4 with vowel patterns.
3 C 58077—Shipping weight 5 ounces \$14.99
Super Stumper™ Module. Helps students with problem words.
3 C 58024—For grades 4 thru 6. Shpg. wt. 5 oz. \$14.99
Super Stumper™ Module. Helps students with words often misspelled.
3 C 58025—For grades 7 and 8. Shpg. wt. 5 oz. \$14.99

(5) **Mr. Challenger™** Spelling Game . . . 4 games in one hand-held unit. Play Mystery Word, Letter Guesser, Crazy Letters and Word Challenge. 500 word memory. Musical tone; green alpha-numeric display. For 1 or 2 players. Instructions. $6\frac{1}{2} \times 3\frac{3}{4} \times 1\frac{1}{2}$ in. deep. Plastic.
AGES, ORDER INFO: 9 yrs. and up. Requires 9-v. battery not included, order below. Warranted by Texas Instruments. Write for free copy, see page 322.
49 C 1777—Shipping weight 10 ounces \$34.97

(6) **Little Learners™** Calculator . . . learning aid for young mathematicians. Enter the problem, push "=" button, receive answer. Adds, subtracts, multiplies and divides. Floating decimal. $6 \times 3\frac{3}{4} \times 1\frac{1}{4}$ in. deep. Solid-state. AC power jack. Plastic. AGES, ORDERING INFORMATION: 5 to 15 yrs. Use AC adapter, not included (see page 560), or 9-volt battery, sold below.
49 C 1772—Shipping weight 7 ounces \$9.49

(7) **Electronic Cash Register Calculator** . . . really works. Adds, subtracts, multiplies and divides. Working keys with buzzer sound. Lighted figures on screen. Open cash drawer; bell rings. Register tape. Play money. On-off switch. $7\frac{1}{2} \times 6 \times 6$ in. high. Plastic.
AGES, ORDER INFO: 5 yrs. and up. Requires 2 "C" batteries not incl., order below.
49 C 1798—Shipping weight 1 pound 9 ounces \$15.99

(8) **Little Professor™** learning aid
CAPACITY: 8-digit red-light display.
TEACHING FUNCTION: 4 teaching levels. Then choose +, -, × or ÷. Unit displays problem, gives 3 tries before giving correct answer. Score given after 10 problems. 4,000 pre-programmed problems per level for children 5 years and up.
CONSTR: Yellow, brown, multicolor face. Plastic. $5 \times 3\frac{1}{2} \times 1\frac{1}{2}$ in. Black fabric strap. Uses one 9-v. battery (not included). Order battery below.
ORDERING INFORMATION: "Fun With Math Facts" book included. Warranted by Texas Instruments. Write for free copy, page 322.
3 C 58063—Shipping weight 12 ounces \$13.99
DieHard 9-v. Alkaline Battery for (3) and (5 thru 9).
49 C 46859—Shipping weight 2 ounces Each \$1.49

(9) **Dataman™** develops math skills
CAPACITY, MEMORY: 8-digit display. Memory stores up to 10 problems.
TEACHING FUNCTION: Uses 4 functions, +, -, ×, ÷ to challenge students 7 years and up with variety of activities and 5 math strategy games. Basic answer checker lets you enter and answer problem. If incorrect, unit gives you second try before giving correct answer. Electronic scoreboard.
CONSTR: Silver-color plastic, $6 \times 3\frac{1}{2} \times 1\frac{1}{4}$ in. Runs on one 9-v. battery (not incl.). Order battery above. Shuts off after 5 min. of non-use to conserve battery power.
ORDER INFO: Warranted by Texas Instruments. Write for free copy, page 322.
3 C 58094—Shipping weight 12 ounces \$19.99



It's all in the game



1 This Rocket Launch action game is a blast! You're the pilot out to destroy enemy planes. When you hit an airborne plane, the screen lights up red to confirm and simulate the destruction. Includes powerful launch sounds and digital hit and miss counters. Imported. Requires 2 "AA" batteries, sold on page 404. For ages 3 years and up. 49 N 65007—Shpg. wt. 1 lb. 2 oz. . . \$9.99

2 The Driving Game puts you in the driver's seat. Test your skills as you race down a 2-lane course. You control the steering and braking. Screen lights up if you crash. Digital lap and crash counters. Imported. Requires 2 "AA" batteries, sold on pg. 404. For ages 3 years and up. 49 N 65001—Shpg. wt. 14 oz. . . \$9.99

3 "Follow Me" gives your memory a workout. Try to repeat the same combination of flashing lights and sounds . . . but pay attention as each turn produces longer and faster sequences. 2 different games. Requires one 9-v. battery, sold separately on pg. 404. Imported. Warranted by Sears, write for a free copy, see page 371. For 1 to 4 players. 49 N 65439—Shpg. wt. 8 oz. . . \$9.99

4 Enter the big league with this Digital Diamond baseball game. America's favorite pastime has never been so exciting. Game has all the action and variations of the real thing. Scoreboard keeps score plus counts balls, strikes and outs. Imported. Requires 2 "AA" batteries, sold separately on page 404. For 2 players. For ages 6 years and up. 49 N 65446—Shpg. wt. 12 oz. . . \$9.99

5 The thrills never stop with Power Action Soccer. True soccer play is achieved with the unique battery-operated mechanism. Built-in scorekeeper. Requires 2 "C" batteries, sold separately on page 404. 49 N 65065—Shpg. wt. 1 lb. 5 oz. . . \$24.99

6 Can you outwit the Wizard? 4 games in 1. Each requires memory, fast action and logic. Match Me is a memory game with 4 levels of difficulty. Music Maker memorizes and plays back any 30-note tune. 16 dancing lights accompany playback. Break Out is a competitive maze game for 2 or more players. Hot Corners is an action game for 4 players. Each player defends his two corners . . . bounce the speeding light away or you are out of the game. A mini computer brain controls 16 lamps and bell tone sounds. Requires 6 "C" batteries, sold separately on pg. 404. For 6 players. For ages 5 years and up. Shpg. wt. 2 lbs. 49 N 65016 . . . \$17.99



Compare

Look at this low price for your choice of three of the most popular electronic sports games ever

\$19.99
each without batteries



Have a road race in your living room, shoot baskets in the kitchen or play football while riding in a car! These hand-held electronic games are fun you can take almost anywhere . . . at a price almost anyone can afford.

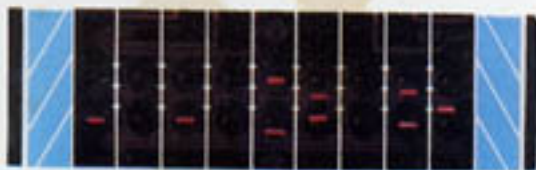

The computer controls the defense and you control the offense as you try to score an **Electronic Touchdown!** Get all the excitement of a real football game as you block, run, kick and even pass. Shake tacklers as you race downfield. Set up a pass play and throw the bomb. Two different skill levels let you speed up the defense to play "Semi-Pro" or "Pro". Two players can compete by controlling the opposing offenses. Electronic sound effects include referee whistles and even a song that plays when a touchdown is scored. LED displays give you time, score, downs, yards-to-go and field position. Solid state design with plastic case 7x4 1/4 x 1 1/4 inches high.

AGES: 8 to adult.

ORDERING INFO: Requires one 9-volt battery or AC adapter, not included, order below.

LAST DATE TO ORDER THIS ITEM IS JANUARY 31, 1980

49 C 65352—Shpg. wt. 12 oz. \$19.99

DieHard 9-volt Alkaline Battery (not shown).
49 C 46859—Shpg. wt. 2 oz. Each \$1.49

AC Adapter for Electronic Touchdown (not shown). UL listed. For use with 6, 7 1/2 or 9-volt electronic games. Miniature and sub-miniature adjustable plugs, 9-volt battery clip tip included. 110-120-v., 60-Hz. AC. 6-ft. cord. Not for children under 8.

49 C 65244—Shpg. wt. 6 oz. \$4.99



Electronic Basketball pits your basketball skills against a computerized defense. It's a race against time as you move onto the court and drive past the defensive players for a lay up. Shoot as many baskets as you can before the timer counts down 24 seconds. Action includes blocked shots and rebounds. Two skill levels let you speed up the defense to make scoring more challenging. Two-player memory lets you take on an opponent. Sound effects for a basket made, turnover, end of quarter, blocked shot and end of game. LED scoreboard. Solid state design. Plastic case measures 5 1/4 x 3 1/2 x 1 1/4 inches high overall.

AGES: 8 to adult.

ORDERING INFORMATION: Requires 4 "AA" batteries, not included, order at right.

LAST DATE TO ORDER THIS ITEM IS JANUARY 31, 1980

49 C 65453—Shpg. wt. 8 oz. \$19.99



Auto Race brings you the thrill of realistic raceway action. Try to complete 4 laps before timer counts down 99 as you shift gears and gun it up to high speed. Avoid collisions by cutting from lane to lane in a series of close calls. Hear your "motor" roar as you shift gears. Hear sound effects for victory, defeat and crack-ups. LED scoreboard shows elapsed time, counts laps and number of collisions. Solid state design. Plastic case. 5 1/2 x 3 1/2 x 1 1/4 in.

AGES: 7 to adult.

ORDERING INFORMATION: Requires 3 "AA" batteries, not included, order below.

LAST DATE TO ORDER THIS ITEM IS JANUARY 31, 1980

49 C 65452—Shpg. wt. 8 oz. \$19.99

DieHard "AA" Alkaline Batteries (not shown). For above and at left. Package of 2.

49 C 46819—Shpg. wt. 2 oz. Pkg. \$1.19



CHRISTMAS is for Children
FAMILY GAME CENTER

G-K Sanyo Sports Watches get you there in style...at a very affordable price! All feature quartz accuracy, day and date, alarm. Resin case and strap (except item J) 2-year warranty on module. In attractive gift box...ready to wrap.

(G) White Sports Watch offers both analogue and digital time. Stopwatch with $\frac{1}{100}$ second chronograph. Hourly chime.
042 527 030—Each 39.99

(H) As Above, but is water-resistant up to a depth of 50 metres; with digital readout only.
042 527 031—Each 39.99

(J) Lightweight Watch is both solar and battery powered. Water-resistant to 30 metres. Stopwatch with $\frac{1}{100}$ second chronograph. Lap reset. Hourly chime. Silvertone case and adjustable bracelet.
042 527 027—Each 34.95

(K) World-Time Calculator Watch tells the relative time in 12 different time zones.
042 527 000—Each 29.99



INNOVATIVE TIME

L-P Precision Quartz Sports Watches by Innovative Time®. Casual looks at low, low prices! All with Black resin case and strap. 1-year warranty on module. Gift boxed.

(L) Alarm Chronograph is water-resistant to 30 metres. 24-hour stopwatch with lap function. Daily alarm and hourly chime.
042 513 011—Each 10.99

(M) Sports Master Watch is water-resistant to 50 metres. Features day/date, daily alarm and hourly chime. 3-lap memory. Stopwatch and countdown timer. Pacer function.
042 513 012—Each 39.99

(N) Super Slim Watch...only 3.5 mm wide! Water-resistant to a depth of 30 metres. Features world-time calculator, shows time in 13 time zones. Date and daily alarm.
042 513 863—Each 19.99

(P) Sports Watch with both analogue and digital time. Features day/date, alarm, swivel bezel, luminous hands. Water-resistant to 30 metres.
042 513 013—Each 29.99

R-W Sports Watches by Casio® are feature-packed and loaded with style...a watch that's functional, reliable...a new concept in time! Choice of 4 super styles, all with quartz accuracy, Black resin case and strap (except item W). 1-year warranty on module. Gift boxed.

(R) Digital Sports Watch is water-resistant to 50 m. Has stopwatch feature with countdown alarm, daily alarm and hourly chime. Both 12 and 24-hour time.
042 513 016—Each 74.99

(T) Digital Sports Watch is water-resistant to 100 m. Unique temperature alarm for outdoor activities. Tells the time in 8 different time zones. Daily alarm and chime every hour and half hour. Stopwatch function. 12 and 24-hour time.
042 513 014—Each 84.99

(U) Digital Sports Watch is water-resistant to 100 m. Functions in extreme temperatures (-30°C to +50°C). Features stopwatch timer and daily alarm, hourly chime.
042 513 015—Each 89.99

(W) Data Bank Sports Watch stores up to 50 phone numbers. Works overtime to give you outstanding good looks and superb features: stopwatch timer, countdown alarm. 5 daily alarms and hourly chime. Smart Silvertone case and bracelet.
042 513 017—Each 109.99

CASIO®



19-INCH TVs—WE GUARANTEE IT



Stereo console . . . no brighter, sharper projection color TV picture!

- Variable audio out, surround, Super VHS, audio/video in and out plus external speaker jacks
- View two shows at once
- Unified remote can control your VCR or cable system

Cut \$320

\$2179

\$55 MONTHLY ON SEARSCARGE PLUS NO PAYMENTS 'TIL JAN.*



BOTH HAVE FULL 2-YEAR WARRANTIES

STEREO
MTS

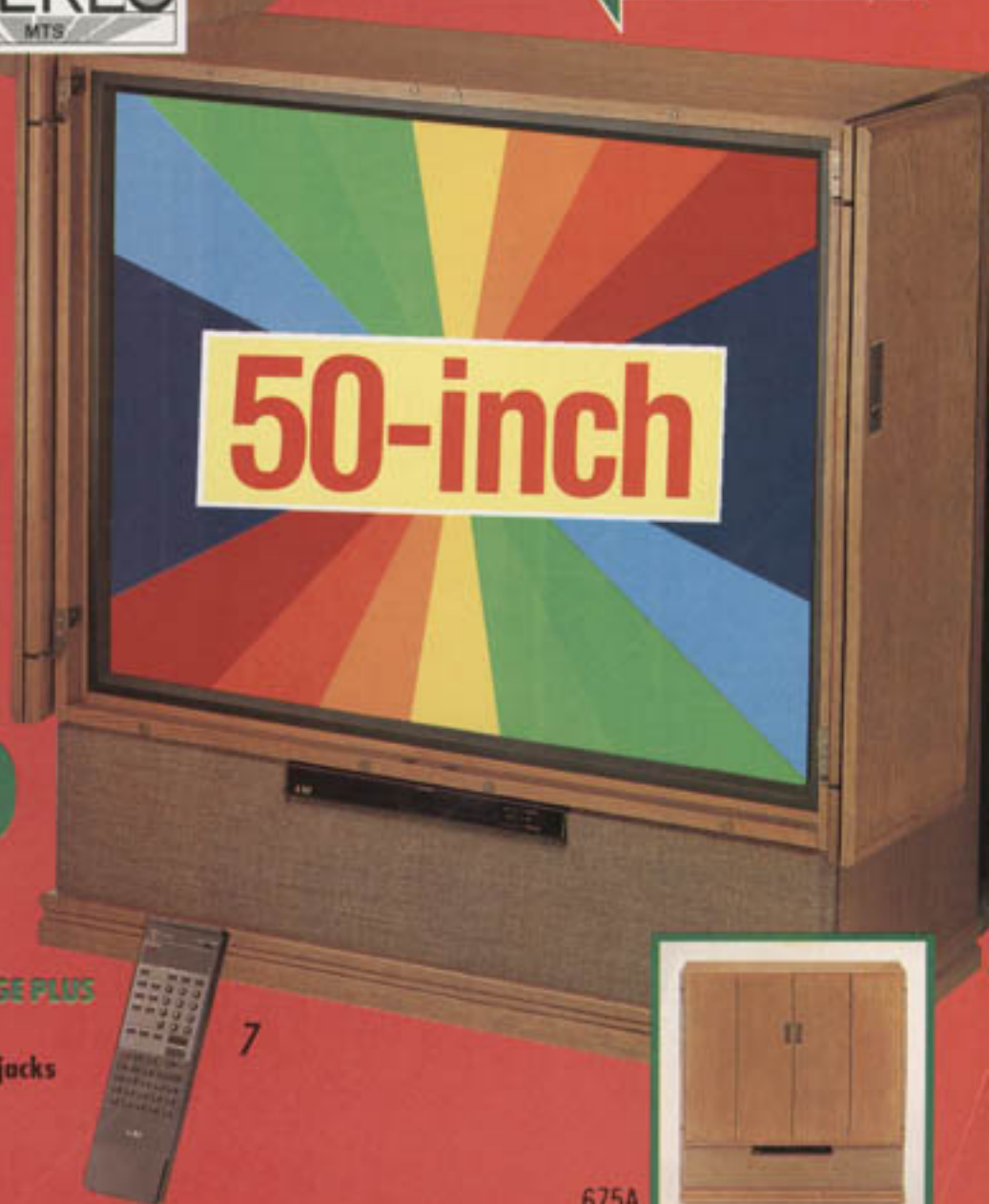

Super-size stereo console TV with contemporary oak-finish cabinet

Cut \$300

\$2499

\$60 MONTHLY ON SEARSCARGE PLUS NO PAYMENTS 'TIL JANUARY*

- Surround, audio/video in and out plus Super VHS jacks
- Remote can control your VCR too!
- 10 watts of stereo sound

*See page 305.



675A

Man Against Machine!

Try to Beat These Computer Games



1
Sensory Chess Challenger®
122⁹⁹ Charge it—
see page 363

2
Sensory Voice Chess Challenger®
349⁰⁰ Charge it—
see page 363

1 Sensory Chess Challenger® "8." New sensory playing surface informs computer of your every move. Playing squares light up to indicate computer's next play and confirms your move. Lets you change sides in mid-game, or will play against itself. Has eight levels of play, from beginner to expert, including "Mate in Two" and "Chess by Mail." Random computer responses vary every game. Has a broad vocabulary of book openings. Plastic housing measures 11½x10½x2½ in. Brown and white playing squares. Staunton-design, brown and white, magnetized plastic playing pieces. Solid state circuitry. Uses 4 "C" batteries (not incl., see page 461) or 110-120V, AC. Plug-in transformer. 6-ft. cord. UL listed.
X 641-3942 A—Delivery weight 2.20 lbs. ... **122.99**

2 Sensory Voice Chess Challenger®. Sensory playing surface informs computer of your moves, with a 50-word voice vocabulary, computer "verbalizes" all your moves as well as its own. Playing squares light up to indicate computer's next move. Strongest program of all Fidelity's Chess Challenger® Series—9 levels of play, from beginner to expert, plus an "infinite" level. Improved book openings—select from 64 variations. Duplicates 64 of the world's greatest Master games. Computerized chess clock tells the time remaining for each player. Solid walnut housing measures 13x11½x3¼ in. Mylar playing surface. Hand-carved, magnetized brown and white wood chess pieces. Solid state circuitry. 110-120V, AC. UL listed. 6-ft. cord. Carrying case incl.
X 641-3959 A—Delivery weight 6.75 lbs. ... **349.00**

3 The Chess Challenger® "7" has seven levels of play, from beginner to expert, including "Mate in Two" and "Chess by Mail." Broad vocabulary of book openings. Even plays against itself. 16 computer keys to enter moves. Staunton-design, brown and beige, magnetized playing pieces. Game has simulated walnut plastic housing, 12x8x1½ in. Playing board is Mylar polyester film over rolled steel, brown and white playing squares. 110-120 V, AC. UL listed. Solid State circuitry means the Challenger can be left "on" for days or weeks. 6-ft. cord. Instructions.
X 641-1268 A—Delivery weight 2 lbs. **89.99**

4 Voice Bridge Challenger® announces the computer's bids in a clear, audible "voice." Endorsed by Alfred Sheinwold, renowned bridge expert. Bids the popular point count systems. Plays one hand as your partner, two (or three) as your opponent, or all four hands as an educational tool. During bidding, uses the popular conventions, Stayman, Blackwood, Gerber, etc. The computer reviews bidding and last trick. Its response times are almost instantaneous. Optical scanner reads custom playing cards, (2 decks included). 3 felt playing fields. Challenger has solid hardwood housing measuring 13½x8½x1½ in. Solid state circuitry. 110-120 V, AC. UL listed. 6-ft. cord. Deluxe carrying case.
X 641-3967 A—Delivery weight 6.50 lbs. ... **339.99**

Extra Set of 2 Bridge Decks for [4].
X 641-2407 A—Del. wt. 0.40 lb. Set **3.99**

5 Modular Game System allows a variety of games to be played on its console. System includes the Boris 2.5 Chess Module, with 7 levels of play. (Additional game modules sold below.) As a teacher, Boris can take you back 3 moves to remedy mistakes, plan mid-game strategies. Will suggest moves for the novice or permit experienced players to experiment. Chess problems can be set up for analysis. Player may elect to change sides at any time during the game. Boris recognizes all the classic moves. Over 80 preprogrammed messages appear on alpha-numeric display that relate to game progress, i.e., "Mate in Two," etc. Includes tournament timer and Staunton-design, black and white plastic playing pieces. Plastic console measures 9x9x2 in. Control panel slides into console for portability. Uses rechargeable battery pack or 110-120V, AC. UL listed. Recharger/adaptor incl.
X 641-3975 A—Delivery weight 4.70 lbs. ... **329.99**

Checkers Module for [5]. Programmed for "World Class" play. Has "restore" feature for using different strategies. Brown and white plastic checkers.
X 641-4973 A—Delivery weight 1.20 lbs. **59.99**

Blackjack Module for [5]. Plays by Las Vegas rules. Deals from 1 to 4 decks of cards (decks not incl.).
X 641-4932 A—Delivery weight 1.20 lbs. **45.99**



3
The Chess Challenger®
89⁹⁹ Charge it—
see page 363



4
Voice Bridge Challenger®
339⁹⁹ Charge it—
see page 363



5
Modular Game System



329⁹⁹ Charge it—
see page 363

Get 3 hours of recording time using rechargeable 2-hour and 1-hour batteries, plus charger

Playback your favorite rental tape or record your favorite TV programs (your TV must have A/V out jacks)

Adjustable 2 1/2-inch electronic viewfinder lets you see what the camera sees... use the review feature to preview quickly

FIRST TIME REDUCED for this movie camcorder!

Cut \$100 \$1189⁹⁹

INCLUDES A FREE 2-HOUR, RECHARGEABLE BATTERY VALUED AT \$49.99!

Includes ALL adapters and accessories!



Connects to any VCR for dubbing of your home movies

Infrared autofocus provides clear, crisp movies... automatic white balance delivers easy point and shoot operation

F1.2 lens with 6-power zoom (8.5-51mm) plus macro setting for dramatic close-ups... 7 lux rating for great low light performance

SHOP AND COMPARE . . . IF YOU'RE THINKING ABOUT BUYING A CAMCORDER ELSEWHERE, THINK AGAIN! WE GIVE YOU ALL THE HI-QUALITY FEATURES LISTED, PLUS ALL ADAPTERS AND ACCESSORIES FOR RECORDING AND PLAYBACK . . . AT A GREAT LOW PRICE! WE THINK YOU WON'T FIND A BETTER OFFER ANYWHERE!

USE THIS HANDY CHECKLIST TO SHOP AND COMPARE!
Camcorder:

- Uses STANDARD VHS TAPE for up to 2 1/2 HOURS of recording time
- Is LIGHTWEIGHT for convenience . . . weighs only 5 1/2 POUNDS (without battery)
- Has 3-WAY POWER . . . battery, AC house outlet or cigarette adapter (optional)
- Takes clear pictures in light as low as 7 LUX
- Plays back your HOME MOVIES on ANY TV (adapter incl.)
- Plays back your favorite RENTAL MOVIE (adapter incl.)
- Records your favorite TV PROGRAM** (adapter incl.)
- Connects to any VCR for DUBBING of your HOME MOVIES (adapter incl.)
- Has UNIDIRECTIONAL BOOM MICROPHONE for clear, clean audio recording
- Includes durable CARRYING CASE, ALL ACCESSORIES, plus HANDLE and CARRYING STRAP

Extra rechargeable batteries. Imported.

O 57 E 53994—1 hour. Wt. 1 lb. . . \$39.99

O 57 E 53995—2 hour. Wt. 2 lbs. . . \$49.99

Tele-slide converter attaches to lens mount of your video camera to put your slides on TV video tape. Slide fits in converter and you just shoot into any light source. Your video camera or camcorder zoom lens crops slides. Adapter rings fit most video cameras. O 57 E 53911—Shpg. wt. 2 lbs. . . \$99.99

Close-up/wide-view lens for video cameras or camcorders lets you shoot as close as 5 inches. Close-up element 3x3 1/2-in. diameter. † O 57 E 53913—Shpg. wt. 2 lbs. . . \$69.99

Telephoto lens for video cameras or camcorders when used with your zoom lens, magnifies images 1.5 times. 3x3 1/2-in. diameter. † O 57 E 53915—Shpg. wt. 1 lb. . . \$179.99

Special effects kit for video cameras or camcorders has multi-imager, rainbow-effect and starburst lens. Transparent optical lens cap. Case, lens pouches. † O 57 E 53917—Shpg. wt. 2 lbs. . . Kit \$59.99

*WARRANTED BY SEARS. Write for free copy, see page 371. Imported.

**Requires TV with A/V out jacks. †Warranted by Ambico. Write for free copy, see page 371. Adapter rings fit most video cameras. All items on this page, allow a minimum of 10 days for delivery.



TODAY'S WAY TO SAY CHARGE IT!
TO APPLY, CALL TOLL FREE 1-800-543-3296

CELEBRATING SEARS NEW CENTURY

WITH THESE EXTRAORDINARY VALUES

Camcorder is a camera plus recorder. * Was \$1289.99 in 1986 General Catalog.

670 O 57 E 53723—Shipping weight 20 lbs. . . \$1189.99



ADAM™

A

B

\$500 scholarship† and ADAM™ Home Software Library†† when you purchase ADAM Family Computer from Coleco

649.99 No money down \$33 a month*

A ADAM computer system has letter-quality printer and built in "user friendly" word processing program. The professional typewriter keyboard has 75 keys. The memory console has 80K RAM. Digital data pack stores up to 500K BYTES of data. Dual drive expansion port for addition of second drive (order at right). Game cartridge slot accepts all standard ColecoVision™ game cartridges. SmartWriter Daisy Wheel Printer is friction-feed and prints up to 120 words per minute bi-directionally on any paper up to 9½ inches wide. 2 game controllers. ADAM also includes SmartBasic™ data pack, one blank digital data pack tape for storage, plus Buck Rogers™! Manufacturer's Warranty.**

67 G 21200 LS—Ship. wt. 19 lbs. 649.99

67 G 22204 LS—Extra digital data pack drive. Ship. wt. 1 lb. 169.99

62 G 1564—Blank digital data pack. Ship. wt. 2 oz. 11.99

62 G 40190—Ribbon for ADAM printer. Ship. wt. 2 oz. 6.95

**Write for a free copy of Mfr.'s Warranty, see page 497.

B ADAM expansion module converts your ColecoVision video game into the ADAM Family Computer. Includes keyboard, printer, memory module with built-in word processing, SmartBasic, blank tape and Buck Rogers. Note: Module will not operate unless connected to a ColecoVision (not included).

67 G 21201 LS—Ship. wt. 15 lbs. 529.99

†\$500 SCHOLARSHIP. Receive a \$500 scholarship direct from Coleco when you mail in coupon and proof of purchase of an ADAM Family Computer or ADAM Expansion Module bought by 12/31/84 and mailed by 2/14/85 to Coleco. Any U.S. residents 15 and under on Dec. 31, 1984 qualify. Receive 4 equal payments of \$125 each as your child completes each year of college. Student must start college by age 19 and go 4 consecutive years full-time at a four year accredited U.S. college. Other restrictions apply as specified in mfr.'s coupon. Void where prohibited by law and taxes are buyers responsibility. Program copyright Coleco, 1984.

††Purchase ADAM Family Computer System or the ADAM Expansion Module and qualify to receive the ADAM Home Software Library free by mail. ALL • 521

1 Bank Shot. Electronic pool with controls that let you cue up, aim, shoot, and angle the shot. Plastic. 8x8½x3 in. Uses 6 "AA" batteries. 1 or 2 players, ages 8 to adult. Will be \$45.29 on Jan. 24, 1981. XU 923-8577 A—Del. wt. 1 lb. **NOW 42.39**



42³⁹
1

2 Electronic Baseball I. 5 different pitches by remote control to the electronic bat—swing for a strike, or connect. Different baseball sounds, a readout for score, balls, strikes, and outs. Plastic. 8½x6¼x1½ in. high. Uses 3 "AA" batteries. 1 or 2 players, ages 8 to adult. XU 923-3743 A—Delivery weight 1 lb. **29.49**



2 Electronic Baseball I
29⁴⁹

3 Battlestar Galactica* Space Alert. Intercept and destroy the Cylon raiders. The computer controls them, you control defensive missile fire. Plastic. 6¼x2½x9¾ in. Uses one 9-volt battery. For 1 or more players, ages 8 and up. Was \$19.99 in our Christmas '79 Catalog. XU 923-3529 A—Del. wt. 0.40 lb. **NOW 16.99**



PRICED DOWN \$3

3 Battlestar Galactica* Space Alert **16⁹⁹**

4 Sensor, the Electronic Scrabble* Game. Match your skill against an opponent or the computer—find the opposition's word in the fewest turns. Lighted display monitors the guesses. Plastic. 8x6x10 in. high. Uses one 9-volt battery. Warranted by manufacturer, see page 363. 1 or 2 players, ages 7 and up. XU 923-3651 A—Delivery weight 1 lb. **31.77**



4 Sensor **31⁷⁷**

5 Lexor, the Electronic Scrabble* Game. Has letter/point-value display, automatic timing and scoring. 3 games: form the most words from 7 letters the computer selects; Scrabble solo with 7 letters, regular Scrabble with 2 or more players. Plastic. 8¼x5¼x9¾ in. high. Uses 4 "C" batteries. Will be \$44.99 on January 24, 1981. XU 923-8627 A—Del. wt. 1.40 lbs. **NOW 42.99**



5 Lexor **42⁹⁹**

6 Comp IV. The computer selects a 3-to-5 digit number. The display shows how many digits you guess are correct, and in the right position. Remember these clues and you'll win. Plastic. 7½x4¼x4¼ in. high. Uses one 9-volt battery. Warranted by mfr., see p. 363. 1 or more players, ages 12 and up. XU 925-2925 A—Delivery weight 2 lbs. **21.29**



6 Comp IV **21²⁹**

7 Slimline Racing. Streamlined so you slip it into your pocket. You control the steering, acceleration, braking. 4 different games: speed control race, car chase, 5-car chase, and derby dash. Metal and plastic. 9½x6¾x2¾ in. Uses two G-13 calculator batteries—batteries included. For 1 or 2 players, ages 7 and up. Will be \$41.49 on January 24, 1981. XU 923-8619 A—Del. wt. 3 lbs. **NOW 38.99**



7 Slimline Racing **38⁹⁹**

8 Maniac. 4 maddening games in 1. Rapid fire patterns of sound and L.E.D. lights. 3 adjustable skill levels. Plastic. 10½x10½x2½ in. Uses one 9-volt battery. Warranted by manufacturer, see page 363. 1 to 4 players, ages 8 and up. XU 923-4147 A—Delivery weight 2.10 lbs. **34.99**



Maniac **34⁹⁹**
8

9 Touch Me. Match the sequences of lights and sounds in 3 games at 3 skill levels. Automatic scoring and score recall. Plastic. 6x3x1 in. Uses one 9-volt battery. Warranted by manufacturer, see page 363. For 1 to 4 players, ages 7 and up. Was \$16.99 in our Christmas '79 Catalog. XU 923-3560 A—Del. wt. 0.40 lb. **NOW 9.99**



Touch Me **9⁹⁹**
9
PRICED DOWN \$7

10 Computer Perfection. Match the pattern of sounds and lights in 4 different games at 3 skill levels. Can you "outsmart" the computer? Plastic. 8¼x8¼x11 in. high. Uses two 9-volt batteries. Warranted by mfr., see page 363. For 1 or more players, ages 8 and up. XU 923-4113 A—Delivery weight 1.40 lbs. **32.88**



Perfection **32⁸⁸**
10

11 Mr. Pop. Kids race the wind-up timer, using 25 different pieces to create hundreds of goofy faces on Mr. Pop's head. When the 60 seconds stop, he pops up and the pieces drop! Plastic. 9x2½x12½ in. high. For 1 or more players, ages 3 to about 7. XU 923-8635 A—Delivery weight 1.40 lbs. **8.88**



11 Mr. Pop **8⁸⁸**

JCPenney 479

CONSUMER INFORMATION: ELECTRONIC GAMES FOR THE WHOLE FAMILY

Electronic games designed for adults and children to play together can promote good family relationships and a healthy spirit of competition. Some require logic and can help a youngster in problem-solving; others help develop memory and attention span. To add variety and continuing challenge, look for toys that play more than one game, have varying skill levels, and can be played by one, two or more players.



A Mouse Trap. Capture another player's mouse before they capture yours. A toss of the dice tells you how to build the trap—a crazy mechanical wonder of gadgets and chain reactions. For 2 to 4 players ages 6 and up.
492 562 951—Each 21.99

B T.H.I.N.G.S.—Totally Hilarious, Incredibly Neat Games of Skill. Pkg. of 2 games—Grabbit and Eggzilla. For 1 or more players ages 5 and up.
492 562 729—Pkg., each 17.99



C Rocket Launch. Alien ships behind clouds. There are 15 ground-to-air rockets for protection. When rocket hits ship a Red light flashes and action stops until restart button is pressed. Digital counter shows number of hits and rockets. For 1 player ages 5 and up. Requires 2 "AA" batteries (not included—sold on page 398).
492 562 174—Each 22.99



D Nerf Indoor Golf turns your home into a miniature 9-hole golf course. Includes 2 golf clubs, 9 ringed holes with attachable flags, 4 different color vinyl golf balls, 1 score pad. Any number of players can play ages 6 and up.
492 562 015 DL—Each 34.99

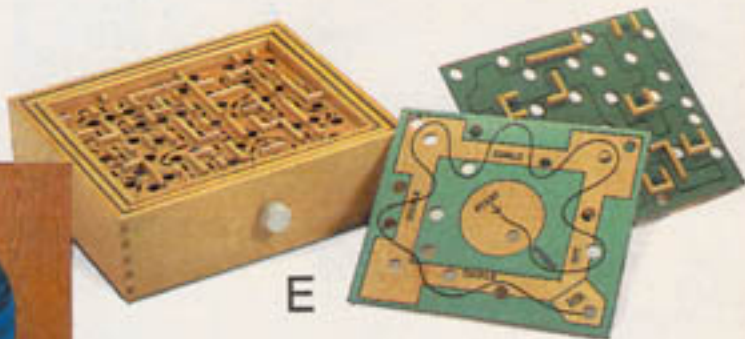

E 3-in-1 Labyrinth with 3 interchangeable tops that includes golf, baseball and labyrinth maze. Great set of games for 1 or more players.
492 562 338—Ages 5 and up. Each 19.99



F Skittle Bowling. Family fun and table-top action. Includes large plastic game base, 10 wooden pins and wooden skittle pole with wood bowling ball. 1 or more players ages 6 and up.
492 562 108—Each 19.99

G Go to the Head of the Class. Adults and children compete together at different skill levels in a fun test of general knowledge. For 2 or more players ages 8 and up.
492 562 963—Each 16.99

H Let's Go Fishing. The action game where players try for the biggest catch. For 1 to 4 players ages 4 and up. Requires 1 "C" battery (not included—sold on page 398).
492 562 285—Each 16.99



K Whack Attack. A crazy contest to see who can whack 5 crazy critters down the most times before the time runs out. For 1 or more players ages 5 and up.
492 562 802—Each 29.99



J Tournament Archery Set. Large metal bow with molded plastic grip, belt, quiver, 2 static targets, 1 moving target, 6 safety-tipped arrows. For 1 or more players ages 4 and up.
492 562 162 DL—Each 29.99



L Dizzy Dizzy Dinosaur. Wind-up "prehistoric" dinosaur for play on an oversized game board. The first to get into the cave without being knocked over by Dizzy wins. 2 to 4 players ages 5 and up.
492 562 286—Each 24.99

M SAVE 3.00. Jenga Game. 54 wood pieces. Remove piece from anywhere in the stack and add to top. The last player to put a piece on top wins. For 1 or more players ages 6 and up. Sears reg. 19.99.
492 562 794—Each 16.99



1/2 Price



New! Q*bert 4

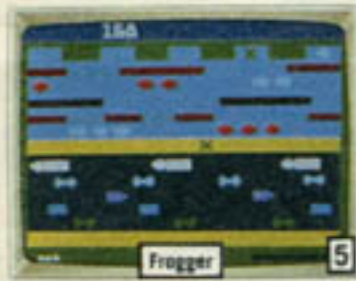

Frogger 5



New! Popeye 6



Burger Time 7



Loco Motion 8



Donkey Kong 9



New! Dragonfire 10



Pitfall 11



New! Star Wars: The Empire Strikes Back 12



Demon Attack 13



Atlantis 14



Swords and Serpents 15



Dracula 16



Nova Blast 17



Intellivoice™ with your choice of 2 cartridges (B) thru (D)

Only \$39.98

Your Choice \$19.99



Your Choice \$17.49



Your Choice \$14.99



Your Choice \$12.49

(A) Intellivoice™. Plug in a talking cartridge (B) thru (D) to produce games with voices. Regular cartridges will produce games without voices. For Intellivoice® or Sears Super Video Arcade. Warranted by Mattel Electronics; see page 323. Save \$99.99 when you buy any 2 Talking Cartridges (B) thru (D) with Intellivoice. Savings only good thru Dec. 31, 1983. Sep. prices totaled \$139.97 in our 1983 Spring Big Book, page 686.
 49 C 75305—Cartridges (B) and (C) with Intellivoice
 49 C 75306—Cartridges (B) and (D) with Intellivoice
 49 C 75307—Cartridges (C) and (D) with Intellivoice
 Shipping weight 2 lbs. 6 oz. \$39.98

(B thru U) When needed, cartridge includes keyed overlays. Warranted by Sears, see page 601, or by Mattel Electronics, see page 323. Reduced from 1983 Spring Book, page 686, or 1982 Wish Book, page 639.

Cartridge name and description	Catalog No.
(B thru D) Talking Cartridges for (A) Intellivoice (B) Space Spartans™ by Mattel Electronics. You are attacked. Computer advises. 1 or 2 players	49 C 75301
(C) Bomb Squad™ by Mattel Electronics. Disarm bomb by guessing its code. 1 or 2 players	49 C 75302
(D) B-17™ Bomber by Mattel Electronics. You are the gunner, pilot, navigator, bombardier. 1 or 2 players	49 C 75303
Shipping weight 4 oz.	Was \$39.99. Now \$19.99

Cartridge name and description	Catalog No.
(E) Dungeons & Dragons®. 1 player.	49 C 75227
(F) Star Strike™. Destroy enemy installations. 1 player	49 C 75231
(G) Space Hawk™. Your only defense is a blaster, jetpack and shields. 1 player	49 C 75233
(H) Night Stalker™. Fight creepy-creepies in cave. 1 or 2 players	49 C 75236
Shipping weight 4 oz.	Was \$34.99. Now \$17.49
(I) Tron: Deadly Disc. 1 player	49 C 75242
(K) Auto Race™. 1 or 2 players	49 C 75206
(L) Armor Battle™. Tactical maneuvering over many terrains. 2 players	49 C 75211
(M) Space Battle™. 1 player	49 C 75212
(N) Boxing. 2 players	49 C 75221
(P) Bowling. 1 to 4 players	49 C 75223
(R) Sub Hunt™. 1 player	49 C 75225
(S) Space Armada™. Aliens march down on your ship. 1 player	49 C 75226
(T) Astrosmash™. Destroy asteroids and suicidal aliens. 1 player	49 C 75229
Shipping weight 4 oz.	Was \$29.99. Now \$14.99
(U) Tennis. 2 players	49 C 75218
(V) Triple Action™. 3 games in one: racing cars, tank battles, biplane dogfights. 2 players	49 C 75230
Shipping weight 4 oz.	Was \$24.99. Now \$12.49

HURRY... LAST DATE TO ORDER THESE PRODUCTS IS DEC. 31, 1983

There's more for your life at
Sears



1 thru 7 These fun robots all have their own unique traits but are all equally lovable. Plastic. Each requires 2 "AA" batteries, except (6) requires 2 "AA" and two 9-volt batteries, sold separately on p. 404. For ages 5 years and up.

1 *Mystabot™* is the mystery action robot... where it goes nobody knows! Bump and go movement, moving legs and flashing lights. 4 in. high. 49 N 54665—Shpg. wt. 10 oz. . . \$7.99

2 *Playbot™ 100*, the remote-controlled robot, will delight you with his whimsical motion. Goes forward and reverse in circular path. Its arms move up and down to grasp articles. Eyes light up. 4 in. high. 49 N 54667—Shpg. wt. 1 lb. 4 oz. . . \$7.99

3 *Smartbot™* has movements that can be programmed by using any of the four cassettes (incl.). Zig-zag, square, forward and reverse motion. Has movable arms for even more fun. 3 1/4 in. high. 49 N 54673—Shpg. wt. 11 oz. . . \$9.99

4 *Acrobot™* is the robot that thinks he's a gymnast. Does acrobatic flips then rights itself for another tumble. Flashing lights. Flips over and picks itself up. 5 1/2 in. high. 49 N 54675—Shpg. wt. 13 oz. . . \$9.99

5 *Musicbot™* will entertain you by playing a musical tune and dancing at the same time! Bump and go action, flashing lights. 4 in. high. 49 N 54677—Shpg. wt. 1 lb. 3 oz. . . \$9.99

6 *Steve the Butler™* is the radio-controlled robot that's always at your service! Use the controller to move it forward or reverse. The manually movable arms can hold the detachable serving tray. Eyes light up. 9 in. high. 49 N 54669—Shpg. wt. 2 lbs. 2 oz. . . \$24.99

7 *Skatebot™* goes forward on its skateboard, then spins and does wheelies like a champion! 7 in. high. 49 N 54671—Shpg. wt. 1 lb. 3 oz. . . \$14.99

8 *Dustbot™* robot really likes to keep an area tidy. Has a built-in vacuum cleaner, moving broom and dustpan action to do the job right. Automatic "non-fall" mechanism. Blinking eyes. Plastic. 5 in. high. Requires 2 "C" batteries, sold separately on p. 404. For ages 4 years and up. 49 N 54706—Shpg. wt. 1 lb. 3 oz. . . \$18.99

9 *Crackbot™* robot has a comical "herky jerky" arm movement that will keep you in stitches. Has a sound sensor action. Plastic. 6 1/4 in. high. Requires 3 "C" batteries, sold separately on p. 404. For ages 4 years and up. 49 N 54707—Shpg. wt. 1 lb. 2 oz. . . \$24.99

10 *Spotbot™* is the futuristic pet. Bumps into objects and runs away yelping. He even chases his tail. Plastic. 4 1/4 in. high. Requires 1 "AA" battery sold separately on p. 404. For ages 4 years and up. 49 N 54711—Shpg. wt. 11 oz. . . \$11.99



A

Gifts under \$100

(A) *Top-grain Cowhide Leather Blazer.* Center vent in back, nylon lining. Professionally leather clean. Imported. Fits men 5 ft. 7 in. to 5 ft. 11 in. tall. *State even chest size 36-46.* X 45 E 63522F—Brown X 45 E 63521F—Tan Shipping weight 2 lbs. 12 oz. . . **\$99.99**

(B) *Limited Edition Endangered Species Collector's Knives.* The natural beauty of four vanishing native American birds is depicted in the hand-carved scrimshaw bone handles of these knives. Each knife signed by the artist and mounted in a 8½x5½-inch walnut plaque with an account of the bird's current status and a map of its range. Only 1000 knives of each bird available, numbered from 1001 to 2000. 3¼ inches long closed. See Note below.
 T 9 E 95173—Bald Eagle T 9 E 95171—Whooping Crane
 T 9 E 95172—Peregrine Falcon T 9 E 95174—California Condor
 Shipping weight 14 ounces. . . Ea **\$80.00**
 Save \$80 when you buy all 4 Endangered Species Knives. Sep. prices total \$320.00. 1000 sets numbered from 1 to 1000. T 9 E 95176—Shpg. wt. 3 lbs. 8 oz. . . Set **\$240.00**
 NOTE: To learn more about endangered species and what is being done for them, write the U.S. Fish and Wildlife Service (Pubs/S) Washington, D.C. 20240.



B

(C) *Compact Stereo System.* Was \$129.95 in our 1983 Spring Big Book, p. 711. Includes AM/FM stereo receiver, cassette player/recorder, turntable and 2 one-way air suspension speakers. Ceramic phono cartridge has diamond stylus. Imported parts, assembled in U.S.A. UL listed. 120-volt, 60 Hz., AC. 5½-ft. cord. 14½x18¼x5½ in. deep. Speaker enclosures are 14½ in. high. See "N" suffix p. 323. See our 1983 Fall Big Book for Sears specific written warranty, or write for free copy, see page 323. 57 E 91810N—Wt. 32 lbs. . . **\$99.95**



D

(D) *TIMEX/Sinclair 1000 Personal Computer with 16K RAM Module.* Just plug module in to back of computer and you're ready to use any of the sophisticated software sold for the Sinclair 1000 in our Fall Big Book. Or write your own programs using the built-in BASIC language. Plastic membrane keyboard allows single-key entry of many commands. Black plastic computer casing is 6½x6¾x1½ in. UL listed. 120-V. AC. Warranted by Timex Corp., see p. 323. 3 E 23024C—Shpg. wt. 3 lbs. 6 oz. . . **\$89.98**



C

(E) *Wilson Walker Cup 7-club Golf Sets with Bag.* Regular length, men's right hand clubs with lightweight steel shafts and composition rubber grips. 1 and 3 woods have Strata-Block laminated hardwood heads with Clima/Gard polyurethane finish for durability. 3, 5, 7 and 9 irons have sole weighted carbon steel heads for loft and distance. Paddle style putter with leather grip. Lightweight nylon bag has comfortable padded shoulder sling and large accessory pocket. 6 E 81199C—Shpg. wt. 16 lbs. . . **\$99.99**



E

(F) *Hand-crafted Solid Wood Rocking Horse.* Walnut stained pine with a fine furniture finish. Tail and mane are Olefin® acrylic fibers, saddle and bridle are leather-look vinyl. 44x14x37 in. high. Seat is 26½ in. high. Partly assembled. See "N" note, p. 323. 49 E 89083N—Shpg. wt. 35 lbs. . . **\$99.99**



F

©Sears, Roebuck and Co. 1983. Printed in U.S.A.
 Cover photograph taken at Woodlawn Plantation, Mount Vernon, Va.
 Illustrations with WINNIE-THE-POOH Characters.
 Copyright 1964 Walt Disney Productions.
 All Rights Reserved.

Commodore 64 educational software programs

Title**	Format	Description	Catalog number	Ship. wt.	Price each
Commodore 64 Educational Programs					
Mastertype	Cartridge	Type words that invade your planet. Increases typing skills.	62G40060	9 oz.	32.99
Kidwriter	Disk	Create your own story book. Pick pictures, then write a story.	62G40061	9 oz.	29.99
Most Amazing Thing	Disk	Encourages numerical problem solving through trial and error.	62G40062	9 oz.	32.99
Facemaker	Cartridge	Help improve a child's memory by creating funny faces.	62G1537	9 oz.	29.99
Alphabet Zoo	Cartridge	Teach your children the relationship of letters to sounds.	62G40063	9 oz.	29.99
Kids on Keys	Cartridge	Introduces your child to the computer keyboard.	62G1538	9 oz.	29.99
Kindercomp	Cartridge	Five games in one! Draw, scribble, name, sequence and math.	62G1539	9 oz.	29.99
Snooper Troops I	Disk	Mystery helping children develop vocabulary and reasoning skills.	62G40064	9 oz.	32.99
Music Construction Set	Disk	Learn music without having to learn an instrument.	62G40065	9 oz.	32.99
Typing Tutor/Word Inv.	Disk	Learning the keyboard is fun. Start with home keys and advance.	62G40066	9 oz.	19.99
Typing Tutor/Word Inv.	Cassette	Learning the keyboard is fun. Start with home keys and advance.	62G1541	9 oz.	19.99
Preschool One	Cassette	IQ builder. Develops letters and shapes recognition.	62G40067	9 oz.	12.99
Reading: What's Different	Cassette	Build essential analytical skills.	62G40068	9 oz.	19.99
Step by Step Basic	Disk	An interactive course that teaches basic programming.	62G1544	9 oz.	49.99
Success with Math	Disk	Add and Subtract. Provides drill and practice. For grades 1-4.	62G1545	9 oz.	21.99
Success with Math	Disk	Multiply and Divide. Self-paced tutorial for grades 2-8.	62G1546	9 oz.	21.99
Mastering the S.A.T.	4 Disks	Pre-test which covers math, verbal and English skills.	62G40069	9 oz.	129.99

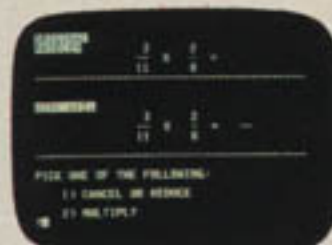

Success with Math



Music Construction



Snooper Troops I



Most Amazing Thing



Insta Writer



Insta Calc



Word Processing



Magic Desk

Commodore 64 personal finance/productivity software programs

Title**	Format	Description	Catalog number	Ship. wt.	Price each
Commodore 64 Personal Finance/Productivity Programs					
Word Pro + 3 with Spelling Checker	Disk	Home or office word processor with built-in dictionary.	62G40070	9 oz.	59.99
Homeword	Disk	Easy-to-use word processing program.	62G40071	9 oz.	59.99
Insta Writer	Cartridge	Create, edit, store and print documents or correspondence.	62G40072	9 oz.	44.99
Insta Calc	Cartridge	Financial spreadsheet for home or personal/professional use.	62G1547	9 oz.	32.99
Multiplan (Microsoft)	Disk	Electronic spreadsheet has what the sophisticated planner needs.	62G1552	9 oz.	84.99
Home Accountant	Disk	Keeps track of 200 plus budget categories for home or business.	62G1550	9 oz.	64.99
File-Catalog-Mail	Disk	Create your own special entry and data retrieval system.	62G40073	9 oz.	44.99
Data Manager 2	Disk	Information storage and retrieval system for 132,000 characters.	62G40074	9 oz.	44.99
Swiftax	Disk	Performs all calculations, worksheets and entries for taxes.	62G40075	9 oz.	44.99
General Ledger	Disk	Keeps records of your financial transactions.	62G40076	9 oz.	44.99
Accounts Payable and Checkwriting	Disk	Make payments for goods and services against invoices from suppliers on open credit.	62G40077	9 oz.	44.99
Accounts Receivable	Disk	Provides information on all invoices and debit/credit memos.	62G40078	9 oz.	44.99
Inventory Management	Disk	Perpetual inventory records for all stock items.	62G40079	9 oz.	44.99
Financial Cookbook	Disk	Helps make complex home financial decisions easier.	62G40080	9 oz.	44.99
Magic Desk I	Cartridge	Type, file and edit. Tell your computer what you want to do.	62G40081	9 oz.	59.99
Data Manager	Cassette	A simplified general information and retrieval system.	62G1548	9 oz.	21.99
Money Manager	Cassette	12-month home or business budget and cash flow system.	62G1549	9 oz.	29.99

Computer supplies and accessories

62 G 40159—9½x11 inch fan-fold computer paper. 875 sheets. Ship. wt. 7 lbs.	16.99
62 G 40160—6 ft. extension disk drive/printer cable for Commodore 64 computer. Ship. wt. 8 oz.	5.99
62 G 40162—Monogrammed computer cover for Commodore 64/VIC 20. Ship. wt. 8 oz.	5.99
62 G 40163—Monogrammed computer cover for Atari 800XL computer. Ship. wt. 8 oz.	5.99
62 G 40164—Verbatim disk drive cleaning kit. Provides 10-15 cleanings. Ship. wt. 4 oz.	7.99
62 G 40167—Verbatim single side/double density disk. 10 pack. Ship. wt. 14 oz.	21.99
62 G 40187—Ribbon for Commodore 1526/MPS 802 printer. Ship. wt. 1 oz.	17.95
62 G 40189—Ribbon for Commodore MPS 801 printer. Ship. wt. 4 oz.	14.95
62 G 40170—Ribbon for Commodore 1525 printer. Ship. wt. 1 oz.	14.95
62 G 40190—Ribbon for ADAM printer. Ship. wt. 2 oz.	6.95
62 G 40191—Ribbon for Epson printer. Ship. wt. 4 oz.	7.95
62 G 40171—SGL Waber spike suppressor. Wall plug/three outlets. Ship. wt. 12 oz.	14.99
62 G 40172—SGL Waber 9¼ in. strip spike suppressor. 6 ft. cord/four outlets. Ship. wt. 1 lb. 12 oz.	17.99
62 G 40173—Twin pack data cassette. 10 minutes each. Ship. wt. 12 oz.	4.99
62 G 40174—Commodore 64 Program Reference Guide. Ship. wt. 1 lb. 2 oz.	19.99

NOTE: Disk software requires disk drive (20142, key B) sold on page 519. Cassette software requires datasette (20102, key F) sold on page 519. Cartridge software does not require storage, but we recommend the use of joysticks or paddies sold on page 519.

For Commodore 64 entertainment software, see page 520.

Commodore 64 computer and a wide assortment of Commodore peripherals are sold on page 519.

**Write for a free copy of Manufacturer's Warranty, see page 497.

5. Verbot is the remote control, voice activated robot. Through his wireless remote microphone you can order him to move forward and backward, turn right or left and pick up lightweight things. You can even tell him when to smile! 9-inch high Verbot requires one 9-volt and two "C" and 4 "AA" batteries sold separately on page 459. Imported. Warranted.*

For ages 7 years and up.
49 C 54574—Shpg. wt. 3 lbs. 3 oz. . . \$49.99

6. Spotbot is the pet of the future. He bumps into objects and runs away yelping. He even chases his tail. 4 1/4 inches high. Requires 1 "AA" battery sold separately on page 459. For ages 4 years and up.

49 C 54711—Shpg. wt. 11 oz. . . \$9.99

7. Hootbot is the owl of the future. He happily sits on his perch (included) with flashing eyes, flapping wings and tapping feet. On the ground, he just waddles away. 7 1/2 in. high including perch. Requires 1 "AA" battery sold separately on page 459. For ages 4 years and up.

49 C 54713—Shpg. wt. 11 oz. . . \$14.99

8. Dingbot is lost—all the time. When he bumps into things he changes direction. Then he'll stop to think and squeals because he can't remember where he was going. Confused? He is too! 4 in. high. Requires 1 "AA" battery sold separately on page 459. For ages 4 years and up.

49 C 54596—Shpg. wt. 1 lb. 12 oz. . . \$9.99

9. Flipbot is the gymnast of the 'bots. He walks into objects and does a backflip. 6 1/2 in. high. Requires 1 "AA" battery sold separately on page 459.

For ages 4 years and up.
49 C 54710—Shpg. wt. 8 oz. . . \$9.99

10. Speak into Talkabot's™ wireless controller and he transmits your voice. He walks at your command through the remote unit. 7 in. high. Requires two 9-volt and four "AA" batteries sold separately on page 459. For ages 5 years and up.

49 C 54572—Shpg. wt. 1 lb. 8 oz. . . \$24.99

11 and 12. Robotix™ sets let you design the motorized space creature or building you desire. Module building system has interchangeable, snap-together pieces. For ages 7 to 14 years.

11. The TYRANNIX Night Attacker™ has a one-switch "droid" power unit. Hide the unit by building it into the machine or keep it separate. Requires 2 "AA" batteries sold separately on page 459.

49 C 54712—Shpg. wt. 3 lbs. . . \$39.99

12. The ARGUS Leader™ is the largest of the motorized building systems. It has four motors and a five-switch master console. Requires four "D" batteries, sold sep. on page 459.

49 C 54570C—Shpg. wt. 5 lbs. . . \$64.99

13 and 14. Robo Strux™ lets you build your own fully motorized monster. For ages 6 years and up.

13. Radox™ is the winged terror of the sky. His wings flap, tail sways and his ferocious mouth opens for the kill! 10 1/2-in. high. Requires two "AA" batteries sold separately on page 459.

49 C 54612—Shpg. wt. 2 lbs. . . \$19.99

14. Terox™ is the most ferocious of the Robo Strux™. His eyes and mouth glow an eerie red, while his arms and jaws rage in motion. 11-in. high. Requires two "C" and two "AA" batteries sold separately on page 459.

49 C 54610—Shpg. wt. 2 lbs. . . \$24.99

*Warranted by manufacturer.
Write for free copy, see page 335.





Fast Shot Aerial Target Game . . . airplane firing control stick makes you a real "ace"

- (1) **Fast Shot Aerial Target Game.** Aim the airplane firing control stick. Fast repeater fire action. Shoots pellets. Automatic scoring. Bell rings and target spins when it is scored. Imported.
CONSTR: 10x8½x7-in. high plastic arcade. Completely enclosed.
AGES, ORDERING INFORMATION: 5 years and up.
49 C 62785—Shipping weight 1 pound 14 ounces \$9.99
- (2) **Demolition Derby Pinball.** Shoot steel ball into play. 2 replay flippers keep ball in play. Automatic scor-o-dial for instant scoring. 9 bell-ringing bumpers. Light flashes when you score.
CONSTRUCTION: Fully enclosed plastic case, 20x10½x12 inches high when set up. 2 steel balls.
AGES, ORDER INFO: 3 to 10 yrs. Partly assembled, instructions included. Needs 4 "D" batteries, not included, order 2 pkgs. below.
49 C 62041—Shipping weight 4 pounds 8 ounces \$14.49
49 C 46849—Alkaline "D" Batteries. Pkg. of 2. Wt. 10 oz. 1.59
- (3) **Aces of the Sky Arcade.** Aim the movable gun to fire single or rapid fire bursts while barrels rotate. Steel balls automatically roll back to be ready for more shooting action. Wind-up moving targets, bell ringers, spinning targets add to variety.
CONSTR: 30x14x14 in. Enclosed plastic. With leg attachments.
AGES, ORDERING INFORMATION: 6 to 10 yrs.
79 C 62166C—Shipping weight 7 pounds 8 ounces \$22.49
- (4) **Dodge City Wild West Gunfight.** Hit the 8 moving targets with the western-style dart gun and 4 rubber suction darts.
CONSTR: 12½x11-in. high plastic arcade; metal back target. Heavy-duty motor winds up with key; runs 2½ min. Imported.
AGES, ORDERING INFORMATION: 8 years and up.
49 C 62784—Shipping weight 2 pounds 8 ounces \$7.99
- (5) **Space Target Game.** Shoot the balls at the 3 hinged colorful, space motif, knock-down targets. Easy-load flip-up targets.
CONSTR: 12x10½ in. durable plastic targets. 4 light plastic balls and repeating action pistol. Imported.
AGES, ORDER INFO: 3 years and up.
49 C 62787—Shipping weight 15 ounces \$4.99
- (6) **Winnie-the-Pooh Ball Darts.** Soft balls stick like magic.
CONSTR: 17x15-in. high brightly colored nylon cloth target; polyurethane backing. 3 Velcro® covered plastic balls.
AGES, ORDER INFO: 3 yrs. to adult. See Note below.
49 C 62722D—Shipping weight 8 ounces \$5.69

NOTE: Win a trip to Disney land. To get your Official Entry Blank, order the Winnie-the-Pooh item on this page . . . see page 2 of Sears 1979 Christmas Catalog for details . . . entries must be received by February 15th, 1980.



Demolition Derby Pinball . . . light flashes everytime you score a hit



Aces of the Sky Single shot or rapid fire for action-filled target shoot



Dodge City Wild West Gunfight

636 Sears MKD



Shoot plastic balls at knock-down targets



Balls stick like magic



CHARGE IT—
see page 334

A
Outer Space
Electric Pinball
32⁸⁸



Battery-Powered
Table Top Pinball
14⁸⁸

C



Battery-Powered
Action Pinball
22⁸⁸

B



D MX-500
Pinball
12⁹⁷



E
Spiral
Ball
7⁹⁹

Folds into its own
carrying case



F
Roto Ball
half hockey,
half pinball
16⁸⁸



Junk Yard
8⁹⁹

G

Toss Across
I **10⁹⁹**



H
Frenzy
11⁷⁷

JCPenney 387

TOYS AREN'T JUST
FOR CHRISTMAS
Save this catalog.
You can order anything
from these two pages—
at these low prices—
till August 13, 1977



New at Sears! Speak & Music helps children learn music basics



1 Speak & Spell has a 150-word vocabulary and 4 levels of difficulty to teach the spellings of easily-misspelled words. Includes activity book. Requires 4 "C" batteries, sold separately on p. 404. Warranted*. For ages 6 years and up. 49 N 17807—Shpg. wt. 1 lb. 13 oz. . . \$43.99
49 N 17833—Braille Speak & Spell
Shipping weight 1 lb. 5 oz. . . \$43.99

2 thru 7 Additional learning modules for (1). Each incl. plug-in module, lesson booklet.

Item/description	Grade level	Catalog Number
(2) "Super Stumpers II" reviews more commonly misspelled words	6 to 8	49 N 17844
(3) "Basic Builders" helps children master hard-to-spell words	2 to 4	49 N 17837
(4) "Vowel Venture" teaches about long vowels and vowel combinations	6 to 8	49 N 17845
(5) "Super Stumpers" teaches about silent letters, double consonants, irregular spellings	4 to 6	49 N 17839
(6) "Mighty Verbs" teaches about past and present verb tenses, spellings	4 to 6	49 N 17843
(7) "Vowel Power" teaches pronunciation and spelling of vowel combinations	2 to 4	49 N 17838

Shipping weight 4 oz. . . Each \$13.99

*Warranted by Texas Instruments. Write for free copy, see page 371.

8 Speak & Music helps your child learn basic concepts of music like pitch, melody and rhythm. With games such as "Musical Word", "Echo" and "Rhythm" featuring multiple levels of difficulty. Activity book included. Requires 4 "AA" batteries, sold separately on p. 404. Warranted*. For ages 6 to 10 years. Shpg. wt. 1 lb. 2 oz. 49 N 17920 . . \$43.99

9 Speak & Math teaches number values and logic with exciting games and over 100,000 word problems. Activity book included. Warranted*. Requires 4 "C" batteries, sold separately on p. 404. For ages 5 to 12 years. Shpg. wt. 1 lb. 6 oz. 49 N 17605 . . \$43.99

Braille Speak & Math
Shpg. wt. 1 lb. 6 oz.
49 N 17606 . . \$43.99

10 Speak & Read uses a 250-plus word vocabulary plus activities like "Word Zapper" and "Picture Read" to familiarize youngsters with letters and words. Activity book included. Requires 4 "C" batteries, sold separately on p. 404. Warranted*. For ages 4 to 8 years. 49 N 17816—Shipping weight 2 lbs. . . \$43.99

11 thru 16 Additional learning modules for (10) incl. plug-in module and activity book.

Item, word lesson and example	Grade level	Catalog Number
(11) "Who's Who at the Zoo": endings and contractions (ING, ED, ES)	1	49N17821
(12) "Dog on a Log": plurals (box-boxes), rhymes (hit-fit), possessives (Joe's)	2	49N17822
(13) "On the Track": consonant blends, (TRain, BLAck, STick, SWell)	2	49N17823
(14) "The Third Circle": suffixes (LY, FUL), "r" controlled vowels (IR, ER)	1	49N17841
(15) "The Millionth Knight": suffixes (TH, MENT, OUS), silent letters (KNee)	3	49N17842
(16) "A Seal That Could Fly": comparative endings (big, bigger, biggest)	1	49N17817

Shipping weight 4 oz. . . Each \$13.99



AC power adapter for (1, 8, 9 and 10). Not recommended for ages under 4. Shpg. wt. 1 lb. 5 oz. 49 N 17806 . . \$9.99

Games you can play on **ATARI 2600 / GEMINI** by Coleco

Expand your cartridge library with some of the best!



Extra cartridges expand the teaching capacity of your Talking Whiz-Kid™



Talking Whiz-Kid™ offers children 5 years and older an audio-visual display with computer-aided teaching

\$69⁹⁹



8

7 Now's your chance to become a whiz! Talking Whiz-Kid™ helps you learn reading, math and spelling by combining special audio/visual features with computer technology. Children are scored on each question and then given a total for each card so they can keep track of their improvement. Includes two-player interactive games and 50 program cards. Display screen folds down and carry handle makes the Talking Whiz-Kid™ a snap to take anywhere. Unit automatically shuts off when left unattended. Requires 6 "C" batteries, sold separately on p. 406. Can be used with AC adapter (8), sold below. Warranted*. For ages 5 years and up.

49 N 17955—Wt. 3 lbs. 10 oz. . . \$69.99

Expand the teaching capability of Talking Whiz-Kid™ with additional vocabulary builder cartridges.

49 N 17956—Ages 6 and 7

49 N 17957—Ages 8 and 9

Wt. each 7 oz. . . Each \$14.99

8 AC power adapter for (7, 9, 10 or 11). UL listed. Not recommended for ages under 5.

49 N 17995—Wt. 10 oz. . . \$9.99

Pre-computer 1000™ teaches typing, history and geography... additional cartridges sold below



\$69⁹⁹

9

9 Introducing Pre-Computer 1000™ for learning fun! Seven built-in programs help child learn typing, programming, math, spelling, geography, history and science. Also includes challenging general trivia questions and word games. LCD display. Games can be used in one or two player mode. Requires 6 "C" batteries sold separately on p. 406, or AC adapter (8) sold above. Imported. Warranted*. For ages 9 and up.

49 N 17824—Wt. 2 lbs. 12 oz. . . \$69.99

Additional learning programs for Pre-Computer 1000™.

49 N 17825—Fantasy cartridge

49 N 17826—General trivia cartridge

49 N 17827—Sports cartridge

Wt. each 5 oz. . . Each \$19.99

10 Learning fun for little hands, Smart Start™ has a large, easy-to-read keyboard. Includes 11 built-in activities and illustrated book containing 150 multiple-choice questions. LED display. Requires 6 "C" batteries, sold separately on p. 406, or use AC adapter (8) sold above. Warranted*.

For ages 5 years and up.

49 N 17616—Wt. 3 lbs. . . \$19.99

Additional Smart Start™ matchbook sets. Each set includes 6 books. Wt. each 13 oz.

49 N 17620—For ages 5 and 6 years . . . Set \$9.99

49 N 17621—For ages 7 and 8 years . . . Set \$9.99

11 The Learning Window™ features a computer-like keyboard, animation and dot-matrix screen. Learn math, spelling, drawing, music and more. Requires 6 "C" batteries, sold separately on p. 406, or AC adapter (8) sold above. Voice cartridge and additional program cartridges sold below. Warranted*. Was \$57.99 in our 1987 Wish Book For Kids. For ages 6 years and up.

49 N 17937—Wt. 3 lbs. 11 oz. . . Now \$49.99

Additional program cartridges for Learning Window™. "Number power" and "I.Q. Builder" cartridges have 5 activities. "Alphabet Soup" cartridge has 3 activities, animation and 50 new words.

49 N 17939—Number power. Ages 8 years and up.

49 N 17940—I.Q. Builder. Ages 6 years and up.

49 N 17941—Alphabet Soup. Ages 7 years and up.

Wt. each 3 oz. . . Each \$14.99

12 Add a friendly computer voice to the fun with the voice cartridge for (11) above. Interacts with all additional Learning Window™ programs sold above. For ages 6 years and up.

49 N 17938—Wt. 4 oz. . . \$24.99

*Warranted by Video Technology Industries, Inc., write for free copy, see p. 304.

Our animated Learning-Window™ gives you a real computer feel with its dot-matrix screen and computer-like keyboard

Increase the fun with additional animation cassettes and voice cartridge

\$49⁹⁹

12



11



Your direct line to the North Pole... **shop by phone.** To order, call your local Sears store



Pac Man game included



59.99

Atari 2600 video game includes Pac Man cartridge, joystick controllers and hours of arcade-like fun at home!

A Bring all the excitement of Atari's coin-operated arcade games home! Programmable console unit includes Pac Man game plus one set of joystick controllers for vertical, lateral or firing movements. Operates on any color or black and white TV with AC adapter (included). Does not interfere with TV reception. TV/game switch box included. Manufacturer's Warranty.*
67 G 95018—Ship. wt. 7 lbs. 8 oz. 59.99

B Paddle controllers for use with Atari 2600 game (A).
67 G 95031—Ship. wt. 14 oz. pair 14.99

C Pro-line space-age joystick by Atari is fun to use with quick-throw control knob for greater maneuverability and fast-action side trigger-style fire button. For use with Atari 2600 game (A).

67 G 94171—Ship. wt. 9 oz. each 19.99

Replacement joystick controller like those shown with Atari 2600 game (A).
67 G 95033—Ship. wt. 8 oz. each 9.99

62 G 49047—AC adapter for Atari 2600 game (A). Ship. wt. 14 oz. 7.99

62 G 49048—TV/game switch for Atari 2600 game (A). Ship. wt. 6 oz. . . 4.99

Save 10% to 15% on Atari 5200 software when you buy 2, 3 or more cartridges

Game cartridges for Atari 5200

Title*	Players	Catalog number	Ship. wt.	Price each	Any 2, each	Any 3 or more, each
Missile Command™	1 or 2	62 G 43400 D	9 oz.	27.99	24.99	22.99
Space Invaders™	1 or 2	62 G 43401 D	9 oz.	27.99	24.99	22.99
Counter Measure	1	62 G 43403 D	9 oz.	27.99	24.99	22.99
Oix	1 or 2	62 G 43404 D	9 oz.	27.99	24.99	22.99
Tennis	1 or 2	62 G 43406 D	9 oz.	27.99	24.99	22.99
Pole Position	1	62 G 43408 D	9 oz.	32.99	29.49	26.99
Star Raiders™	1	62 G 43409 D	9 oz.	32.99	29.49	26.99
Galaxian™	1 or 2	62 G 43410 D	9 oz.	32.99	29.49	26.99
Centipede™	1 or 2	62 G 43412 D	9 oz.	32.99	29.49	26.99
Kangaroo™	1 or 2	62 G 43413 D	9 oz.	32.99	29.49	26.99
Vanguard	1 or 2	62 G 43414 D	9 oz.	32.99	29.49	26.99
Dig Dug™	1 or 2	62 G 43416 D	9 oz.	32.99	29.49	26.99
Space Dungeon	1 or 2	62 G 43417 D	9 oz.	32.99	29.49	26.99
Jungle Hunt	1 or 2	62 G 43418 D	9 oz.	32.99	29.49	26.99
Ms. Pac Man™	1 or 2	62 G 43419 D	9 oz.	32.99	29.49	26.99
Pengo	1 or 2	62 G 43420 D	9 oz.	32.99	29.49	26.99
Joust	1 or 2	62 G 43421 D	9 oz.	32.99	29.49	26.99
Defender™	1	62 G 49145 D	9 oz.	32.99	29.49	26.99



Pole Position



Centipede



Kangaroo

*Write for a free copy of Manufacturer's Warranty, see page 497.

See page 531 for our line of video game storage cabinets.

See the Atari 800 XL personal computer, peripherals and our complete line of exciting Atari computer software on pages 522-523.

PLAY & LEARN



E

B SAVE \$10 when purchased with Ray-O-Vac batteries—see pg. 484. Quiz Wiz™, shown opp. pg. The computer with 1001 questions and answers! Correct answers get green light, "beep;" wrong answers get red light, "raspberry." Cartridge/Quiz Book No. 1 (general topics) is included. More sold below. Use 9-v battery; order pg. 483. Ages: 6-up. More electronic toys pgs. 482-485, 491.

48 T 14408—Ship. wt. 8 oz. 19.77

CARTRIDGE/QUIZ BOOKS: 01 People & Places; 02 Guinness World Records; 03 Trivia; 04 Book of lists; 06 NFL Players; 09 Misused Words; 10 World of Sports; 11 Super Trivia; 12 Rock and Roll; 13 From the Bible.

L 48 T 14046 X—State item no. Wt. 8 oz. each 5.94

SAVE 50¢ each when you buy 3 or more; 3 or more each 5.44

C 1913 Model T Ford bank with Montgomery Ward logo is a limited edition for collectors! Die-cast replica has free-wheeling spoke tires, high riding fenders, running boards, open driver's cab, authentic Ford markings. Slot in van takes most coins. Key opens bottom door. Metallic green. AGES: 3 up. 5½x2½x3¼ in. high. More banks, pg. 311.

48 T 23790—Ship. wt. 1 lb. 2 oz. 8.99

D Old-fashioned rocking horse, shown opposite, has saddle, reins, stirrups; furry cotton/nylon covering. Hardware base, 30-in. high. Lovable playmate for cowpokes ages 3-6. More riding toys, pgs. 443-450.

48 T 25287—Ship. wt. 21 lbs. 99.99

Battery powered airplane

E Fun-filled plane has soft rounded contours, bright colors, a warm smile and numerous play features to entertain children ages 2-7. Battery-powered/manual steering combo provides spinning "carnival ride" effect. Under seat storage, working rudder, propeller with noise-maker and detailed cockpit. Polyethylene. Two 6-v. motors, recharger included. More riding toys, pgs. 443, 446-450.

48 T 13482—Wt. 24 lbs. Order 6v. batt. pg. 449. 79.99

F Giant Ford tractor/loader/backhoe is rugged 1/12 scale die-cast replica. Realistic steering with knee-action front axle. Front end loader scoops, dumps, locks into position. Backhoe really digs up earth as rear stabilizers brace tractor. Rust-resistant metal. Front, rear rubber tires. 21½x5¼x9¼-in. high.

48 T 23407—More vehicles pgs. 472-477. Wt. 9 lbs. 32.99

G 1,000 dominoes—the perfect party plus. Have your friends set up dominoes about an inch apart. Then topple the first one and watch the domino theory at work! All wood, some with paint imperfections. More games, pgs. 480-491.

48 T 14888—Ship. wt. 11 lbs. 29.97

H SAVE \$10 when purchased with Ray-O-Vac batteries—see pg. 484. Electronic Quarterback™—the football game where you control the action! Call the plays—kick, pass, run or block. Display shows game stats. Electronic sounds. 2 skill levels. Uses 9-v battery, not incl.; order pg. 483. More electronic games pgs. 482-484, 490, 491.

48 T 14540—AGES: 8 up. Ship. wt. 6 oz. 22.97

I Dungeons and Adventures®—A Wards exclusive fantasy gaming adventure! Can be used with Dungeons and Dragons® game. Double set has 14 metal figures, game rules, playing field, dice, dungeon background. AGES: 11 and up. More games pg. 480-491.

48 T 14270—Ship. wt. 1 lb. 27.99

J Matchbox Sounds of Service garage. 7 sounds: Horn, faulty starter, gas pump, air wrench, muffler, engine idle, grease gun. 2-levels with adjustable ramps, 2 service hoists, 2 garage doors, 20x30-in. playmat. Plastic. Vehicles not incl.; buy sep., pg. 472. AGES: 3 up. Uses a 9-v. batt., not incl.; order pg. 380. More playsets pgs. 467-469, 473.

48 TF 23641—Ship. wt. 4 lbs. until Dec. 1, 24.99

48 T 23641 after Dec. 1, 28.99



F



G



H



I



J

Another Atari® breakthrough! The XE video game system has everything the advanced player needs to play the most complex and exciting games . . . superior memory, computer-based technology and full-function keyboard!





- ✓ **Full-function keyboard gives enough versatility to handle sophisticated arcade and advanced computer games**
- ✓ **Game console has as much power as a computer...an amazing 64 kilobytes of memory**
- ✓ **Comes with Atari's best-selling Flight Simulator II computer game (shown at left), plus Missile Command™ and Bug Hunt™**

Set **\$149⁹⁹**

1 For the most lifelike graphics and animation, Atari's® XE game system has everything for advanced playing. Choose from games that require keyboard interaction, exciting target and shooting games or games that require quick decisions . . . just use the keyboard, "gun" or (one) joystick, all included with the system. Additional game cartridges sold below. Warranted by Atari*. For ages 10 years and up. 49 N 65651—Wt. 14 lbs. 8 oz. . . Set \$149.99

Games (below) for the XE system offer colorful, lifelike graphics. Use *Barnyard Blaster™* game with "gun" and *Gato™* game with keyboard. All other games use with joystick. Order from screens below. Warranted by Atari*. Wt. 8 oz.

*Write for free copy, see page 304.

					
Ace of Aces™ 49 N 65729 . . . \$29.99	Ball Blazer™ 49 N 65658 . . . \$24.99	Barnyard Blaster™ 49 N 65652 . . . \$24.99	Blue Max™ 49 N 65661 . . . \$24.99	Centipede™ 49 N 65718 . . . \$19.99	Donkey Kong Jr.™ 49 N 65725 . . . \$24.99
					
Fight Night™ 49 N 65654 . . . \$24.99	Food Fight™ 49 N 65723 . . . \$24.99	Football™ 49 N 65722 . . . \$19.99	Gato™ 49 N 65669 . . . \$29.99	Hardball™ 49 N 65656 . . . \$24.99	Jungle Hunt™ 49 N 65724 . . . \$24.99
					
Mario Bros.™ 49 N 65668 . . . \$24.99	Midnight Magic™ 49 N 65726 . . . \$24.99	Moon Patrol™ 49 N 65727 . . . \$24.99	Necromancer™ 49 N 65728 . . . \$29.99	One-on-one Basketball™ 49 N 65665 . . . \$24.99	Tennis™ 49 N 65721 . . . \$19.99



I



J



L



K



I Rocky Rock 'em Sock 'em™ action playset provides hours of fun helping Rocky and Mr. "T" duke it out. Be the first player to knock your opponent's block off and win! 48 G 51151—Ages: 7 and up. Ship. wt. 5 lbs. 8 oz. 18.88

J Pac Man™ Magnetic Maze™ from Tomy. Pac Man tries to gobble up the magnetic pieces without getting trapped by the monsters in the maze. You control Pac Man by using the joystick provided with the game. Ages: 5 and up. 48 G 51122—Ship. wt. 1 lb. 12 oz. 9.77

K Deluxe Scrabble Crossword Game. Now, the perennial favorite comes in a deluxe edition! This elegant version is the perfect step-up for devoted Scrabble players. The playing surface spins smoothly on a built-in turntable base, and the squares are recessed so tiles won't slide out of place. Comes complete with playing board with revolving base, 100 hardwood tiles, 4 tile racks, scorepad and a drawstring bag to hold tiles; rule booklet. For 2, 3 or 4 players, ages 8 to adult. 48 G 14420—Ship. wt. 4 lbs. 10 oz. 19.97

L Super Bowl Electric Football Game. Realistic looking NFL® game brings the Super Bowl right into your own home! Each player has his own I.D. number and can be posed 5 different ways. Sturdy steel game board is 16x32 in. Adjustable scoreboard with automatic timer. UL listed. Comes with safety plug and a 5-foot cord. Ages: 8 and up. 48 G 14552—Ship. wt. 5 lbs. 14 oz. 27.88

M Quiz Wiz™ question and answer computer for kids. With cartridge/Quiz Book No. 1; 1001 Questions and Answers. Machine tells you if you're right or wrong. No. 28 Quiz Wiz cartridge sold separately below. Uses one 9-volt battery (not included, order page 490). 48 G 14408—Ages: 6 and up. Ship. wt. 8 oz. Order after Oct. 1, 1984. 19.99

Quiz Books for (M) above. State item no.: 03—Movies & TV, 05—Trivia, 23—Words, 26—The Bible, 28—Ripley's, 30—Funny Animals. L 48 G 51601—Ship. wt. 8 oz. any 2 for 11.88

N Set of 2 games teach patriotic trivia. "See the U.S.A." is a fast-paced game that has the players peg in cities and points of interest on the map by their starting letter. Speed is important—sand timer controls turns. "Know Your America:" 7 categories of trivia test your knowledge of the U.S. Over 300 questions and answers. For 4 players. 48 G 14792—Ages: 10 through teens. Ship. wt. 3 lbs. 13 oz. set 9.99



M



N

Smart phones!

Genesis® Telesystem . . . it's the beginning of a whole new generation of personal communications systems

Even the Console is not just a telephone . . .

The Console's standard features include a basic telephone with a state-of-the-art touch-sensitive keypad; one touch calling of 3 (illuminated) emergency numbers and 7 frequently called numbers; any number redial; hold function; call progress monitor; group listening capability (via a built-in speaker) and 4-position ringer control (Low/Medium/High/Off). 20-character alphanumeric display screen gives you step-by-step operating instructions and serves as a clock, programmable alarm, call timer as well as calendar. Console adapts to wall-mount unit with Wall Mounting Kit (sold separately below). System plugs into modular telephone jack. Operates in both rotary and Touch-Tone® service areas. Warranted by American Bell; write for your free copy, see page 323. See Installation Note on page 393.
3 E 24301C—Shipping weight 5 pounds \$349.99

(A) Add extra dimensions with one or more Cartridges . . .

Use Call Waiting, Three-way Calling and Call Forwarding services with one touch accuracy. Custom Calling Convenience Cartridge. You'll be able to activate and use any of these services without the bothersome access codes, fumbling with the switchhook and other annoyances required with your present telephone. The Status Monitor displays the service in use and its current status on the Console's display. Cartridge also provides you with 5 additional one touch calling numbers.
3 E 24315—Shipping weight 2 ounces \$31.99

Automatically and continuously dial busy or unanswered numbers up to 10 times at the interval you select. Deluxe Auto Dialer Cartridge (not shown). Console speaker turns on automatically during auto redial attempts so you'll know when your call goes through. Cartridge also provides you with 9 additional one touch calling numbers.
3 E 24316—Shipping weight 2 ounces \$31.99

Prevent unauthorized long distance or operator-assisted calls. Electronic Padlock Cartridge (not shown). Especially recommended for business applications. Keypad Lock restricts calls to your emergency one touch calling numbers. The Timer Tone reminds you how long you've been on a call at the interval you select (from 1 to 10 min.)
3 E 24317—Shipping weight 2 ounces \$31.99

Wall Mounting Kit (not shown). Includes ABS plastic mounting base, 8-inch telephone line cord, 12-foot handset cord, 3 anchor bolts, instruction sheet.
3 E 24303—Shipping weight 6 ounces Kit \$9.99

*Registered Service Mark of AT&T *Trademark of AT&T



Cartridges snap quickly and easily into the left side of the console



16 of the most important people in your life are now a one-button phone call away

The Touch-a-matic® 1600 telephone, featuring fast and accurate one-button dialing, gives you a feeling of added security during an emergency, as well as eliminates annoying dialing mistakes and the frustration of not being able to find a number when you need it. This easy-to-program Touch-Tone® phone, with 16-number memory automatic dialer, features a touch-sensitive keyboard with 3 locations dedicated to emergency numbers (each appropriately color coded for instant identification), 12 locations for frequently called numbers (of up to 11 digits each), plus one location for automatic dialing of the last number called. The lightweight handset features a powerful electric transmitter for better voice transmission. Digital display shows time/date, number being dialed, or serves as automatic call timer (up to 99 min. 59 sec.) Operates in Touch-Tone® service areas only. Plugs into modular phone jack. Memory unit operates on 4 AA long-life batteries, so it works perfectly even during electrical power failures. Adaptable for wall or table use. Warranted by American Bell; write for free copy, see page 323. See Installation Note on page 393.
3 E 24270C—Smokekey pearl (gray). Shpg. wt. 2 lbs. 8 oz. \$149.99

*Reg. Trademark of AT&T *Reg. Service Mark of AT&T *Trademark of AT&T



Here's how it works:

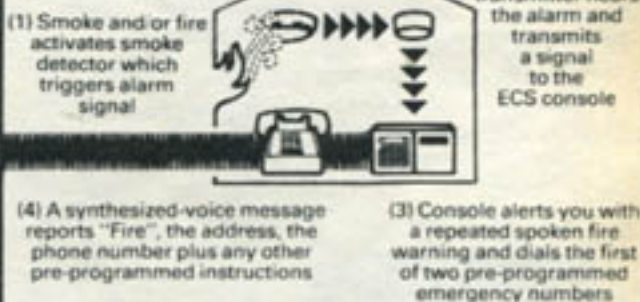

Introducing a fire alert system that's smart enough to phone for help . . . even if you're away

(1 and 2) The Emergency Call System Smoke/Fire Alert begins where your smoke detector leaves off, filling the gap in home protection and safety. See "How it works" story above. Warranted by American Bell; write for your free copy, see page 323. See Installation Note on page 393.

(1) Emergency Call System Console. The same synthesized voice that announces the emergency message also helps you through the keyboard programming sequence and warns you if you made an error. Adaptable for wall or table use. Plugs into modular wall jack and AC electrical outlet. Compatible with both Touch-Tone and rotary dial systems. Battery-powered 24-hour back-up system prevents loss of programmed info in case of power failure (batteries not included). Features low battery warning signal. 7-ft. modular line cord and hardware included.
3 E 24325C—Shipping weight 3 pounds \$229.99

(2) Emergency Call System Transmitter. One transmitter needed for each smoke detector in your home. Features low battery warning signal. Uses one 9-volt battery (included)
3 E 24326—Shipping weight 8 ounces Each \$29.99

ELECTRONIC GAMES OF SKILL



1



2



3



4

- (1) Advanced backgammon players. Omar is here to challenge you

\$57⁹⁹ without batteries

The computer is programmed to play all advanced backgammon strategies. Features include: electronic dice entry, electronic doubling cube, position verification, liquid crystal display, game scoring and detection of illegal moves.

CONSTRUCTION: Plastic unit, 6 $\frac{1}{2}$ x3 $\frac{1}{4}$ x1 inch high. Includes: self-sticking identification numbers that are placed on game board (not included) to correspond with the symbols used by the computer, and instructions.

ELECTRICAL INFORMATION: UL listed. 110-120 volt, 60-Hertz. AC with adapter with 6 ft. cord (included) or uses 4 AA batteries (not included).

ORDER INFO: Warranted by Cardinal Industries, Inc. For free copy, see p. 322. 3 C 2845—Shipping weight 1 pound\$57.99

- (2) Pit yourself against the computer with the Backgammon Challenger®

\$99⁹⁹

You roll the dice and enter your move, the computer varies its strategy to match your game whether it's a running, a hit and run or a blocking and bear off game. Computer plays either offense or defense, with random responses varying each game. The computer does not permit illegal moves. Other features include: built-in doubling and position verification by memory recall.

KEYBOARD, PLAYING BOARD: Simulated walnut plastic housing, Mylar® polyester film keyboard, playing field. 12x8x1 in. overall. Keyboard has 16 keys. LED display for moves.

PIECES: 30 magnetic pieces.

ELECTRICAL INFORMATION: UL listed. 120 volt, 60-Hertz. AC. 6-foot cord.

ORDER INFO: Warranted by Fidelity Electronics, Inc. For free copy, see p. 322. 3 C 2854—Shipping weight 2 pounds\$99.99

- (3) Play Electronic Mastermind and try to break the hidden number code

\$24⁹⁹ without batteries

You set the code for another player to solve, or the computer can set one for you. Three different challenge levels allows you to choose the degree of difficulty. For each test number, the computer read-out tells how many digits are correct and in the right sequence. Try to guess the code in as few tries as possible. For one or more players.

CONSTRUCTION: Plastic unit, 5 $\frac{1}{2}$ x3 $\frac{1}{4}$ x1 $\frac{1}{4}$ in. high. Vinyl carrying case. Score pad and pen, instructions included.

FOR AGES: 8 years and up.

ORDERING INFORMATION: Warranted by Invicta Plastics (U.S.A.) Ltd. Write for free copy, see p. 322. Uses 2 AA batteries, not included.

3 C 2872—Shipping weight 1 pound\$24.99

- (4) Outsmart your opponent and find the hidden word playing Sensor™ electronic word game

\$32⁹⁹ without batteries

The object of the game is to find your opponent's hidden word in the fewest turns. Match wits with an opponent and program your own hidden words or play alone against the computer's built-in word bank. The computer's lighted display monitors your attempts.

CONSTRUCTION: Plastic unit, 8 $\frac{1}{2}$ x5 $\frac{1}{2}$ x9 $\frac{1}{4}$ inches high. Score pad, instructions included.

FOR AGES: 8 years and up.

ORDER INFO: Warranted by Selchow & Righter Co. Write for free copy, see p. 322. Uses one 9 volt battery or AC adapter not included.

3 C 2928—Shipping weight 1 pound 8 ounces\$32.99

*Reg. DuPont T.M.

Pocket Secretary Calculator

Includes 5-function 8-digit electronic calculator with MEMORY and PERCENT, plus all this: leather-look vinyl wallet, ballpoint retractable pen, note pad for memos and a clear plastic credit card-ID protector with 8 compartments



Lightweight. Note pad is removable. There is also space for money or documents



The vinyl wallet features clear plastic pockets for photos, credit cards, "I.D."



So handy, so compact it fits easily into the inside coat pocket or lady's purse



Thin design—calculator and wallet 1/4 in. thick



\$38⁹⁵

An efficient calculator that you can take *anywhere*. Miniaturized to wallet size. It's handy, convenient and easy to use. All functions are at your fingertips. Not only adds, subtracts, multiplies and divides like a regular calculator, but also has percent key and memory.

Features include an automatic constant to make multiplication or division of a long series of numbers quick and easy; a floating decimal that positions itself automatically to insure greater accuracy; a storage memory that stores numbers, and then lets you recall that number whenever you wish. A real time-saver.

With common sense algebraic logic that works problems just as you would write them down. Elegant vinyl leather-like wallet in saddle tan. Operates on one disposable battery (two batteries are included). Instructions. Overall: 7x4x3/4 inches.

3 C 5899—Shipping weight 11 ounces \$38.95

Replacement Mallory Alkaline Battery. For calculator above.

3 C 8986—Shipping weight 4 ounces \$2.49

Rechargeable Electronic Calculators

1 Scientific Calculator with scientific notation, 3 exponential keys, 3 memories, full logarithmic and trigonometric functions, statistical functions, mean and standard deviation; capable of converse rectangular coordinate/polar coordinate functions. 8 mantissa digits; 2 exponent, 2 negative sign digits. 51 operations; 39 keys, 12 dual function. Algebraic (pencil and paper) logic. Exponential keys: Permit entry onto exponent field in display. Increase and decrease keys change exponential results to preferred number without basically altering mantissa.

Memories: Two independent storage registers plus automatic memory summation key. Special keys: Degree/radian mode. Parenthesis. Log keys: Natural and common logarithms and antilogarithms. Trigonometric keys: Sine, cosine, tangent, and their inverses. Power keys: Raise a number to powers; squares; square root, x root of y. Pi with recall. Standard keys: Exchange x and y values. Change sign (plus, minus) of display number. Reciprocal. Clear entry and clear all. Add, subtract, multiply, divide. Calculator dimensions: 5 3/4 x 3 x 1 1/4 inches. Plastic body. Comes with vinyl pouch, rechargeable batteries and UL listed adapter-recharger for 110-120-volt, 60 Hertz AC. 8 watts. 6-foot cord. From Japan.

3 C 5885C—Shipping weight 2 pounds \$58.95

2 5-function 8-digit Calculator with memory; large, clear and bright green fluorescent display; total performance percent key; automatic credit balance indicator; exchange key. Memory lets you work two problems at once. Percent key computes percentages automatically, lets you add them to or subtract from total instantly. Common sense algebraic logic. Adds, subtracts, multiplies, divides. Automatic constant for multiplication, division. Floating decimal. Plastic body. 5 1/2 x 3 1/4 x 3/4 in. Comes with vinyl pouch, rechargeable batteries and UL listed adapter-recharger for 110-120-v., 60 Hz AC. 3 watts. 6-ft. cord. Japan.

3 C 5846—Shipping weight 1 pound \$28.95

Adjustable Stand for (1) and (2)

\$28⁹⁵

3 Speeds up work, frees hands, reduces glare. Raises to 3 positions up to 3 1/2 inches high. Plastic. 7x3 in. Folds down.

3 C 4015—Shpg. wt. 5 oz. \$2.89



Scientific Calculator
\$58⁹⁵



5-function
8-digit Calculator
with memory
and percent

\$28⁹⁵



Shown above are the AC adapter-recharger and black vinyl pouch included with both calculators.

Instant Translator

Interprets words and phrases from one language to another at the touch of a few buttons . . . and it's a calculator and metric definer, too

Ordering an omelet in Yokohama could be a problem if you don't speak a word of Japanese. Now there's a way for you to communicate clearly in Japanese as well as German, French, Italian or Spanish—without saying a word—using this electronic interpreter and optional language capsules.

IT'S SO SIMPLE TO USE WHEN YOU TRAVEL

To translate words just enter them in English, press a button and see the foreign words flash on the screen in big blue letters. To help speed a "conversation", fifty common full and partial phrases are programmed into the unit and each is listed on its back along with a code letter. Tapping the phrase key and that code letter displays the entire phrase, instantly.

PRESS [PHR] TWICE PLUS LETTER FOR PARTIAL PHRASE

A Do you speak	L I would like
B How do you say	M How much
C Take me to	N Is there
D I am looking for	O What is
E Where is	P Is this
F How far is	Q Can you recommend

50 common phrases are programmed into the unit



A 1200-word English capsule is incl., there's space for two more capsules within the unit so you can even translate between foreign languages.



IT'S A GREAT LANGUAGE TEACHER

The computer can flash all of the words within its memory by category (for instance, all the words related to travel like "car", "fare", "ticket", etc.) by their frequency of use or alphabetically. It even helps correct misspelling and can clear-up double meanings (by asking whether the word "watch" means "to see" or "a clock", for example).

When long phrases won't fit on the 16-character display, they move across the screen (you can even control speed of movement). Plastic case; 6 3/4 x 3 1/2 x 1 1/2 in. high. Vinyl carrying case. Includes adapter for use with 110-120-v., 60-Hz AC. ORD. INFO: Order 4 AA batteries below. 3 C 1842C—Shpg. wt. 2 lbs. \$198.95

ORDER LANGUAGE CAPSULES HERE

Each has about a 1200-word vocabulary. Phonetic Capsule shows how to pronounce foreign words.
 3 C 1843—French 3 C 1844—Spanish
 3 C 1845—German 3 C 1848—Italian
 3 C 1847—Japanese 3 C 1846—Phonetic
 Shipping weight each 2 ounces Each \$24.49



(1) Sears Print, Display Calculator CAPACITY, MEMORY: 12-digit display. 4-key fully addressable memory stores subtotals you wish retained . . . to enter figures press appropriate key. ARITH FUNCTIONS: Adds, subtracts, multiplies, divides. Automatic constant for multiplication and division. SPECIAL KEYS, FUNCTIONS: Floating decimal, add-mode system. Non-add print key. Item count in addition, subtraction. Percentage, negative entry, square root keys. Electric paper advance. CONSTR: Plastic body, 7x3x1 in. Vinyl case, 1 roll tape incl. Imported. ELEC. INFO: UL listed. 110-120-v., 60-Hz. AC. 4 w. 6-ft. cord. Uses rechargeable batteries or AC adapter/recharger (incl.). ORDER INFO: Instructions incl. See one-year warranty below, right. 3 C 5804C—Shpg. wt. 3 lbs. . . . \$78.99

(2) Extra tape. Package of 6 rolls. 3 C 58009—Wt. 6 oz. Pkg. \$1.99 Save \$6.03 when you buy (1), (2). Separate prices total \$80.98. 3 C 58051C2—Wt. 4 lbs. \$74.95

(3) Sears LC-83 credit card-size Calculator CAPACITY, MEMORY: 8-digit liquid crystal display. Fully addressable 4-key memory stores subtotals you wish retained . . . to enter figures press appropriate key. ARITHMETIC FUNCTIONS: Adds, subtracts, multiplies, divides. Automatic constants. Chain and mixed calculations. SPECIAL KEYS, FUNCTIONS: Floating decimal. Square root, percentage keys. Memory-in-use indicators. CONSTR: Gold-color metal body 3 3/4 x 2 1/4 x 3/16 in. Case included. Uses 2 silver-oxide batteries (included). ORDER INFO: Instr. incl. See 1-yr. warranty below, right. 3 C 5850—Shipping weight 3 ounces \$14.49

(4) Casio CQ-81 Electronic Calculating Clock Acts as a clock, alarm or calculator. CAPACITY, MEMORY: 8 digit liquid crystal display. Fully addressable memory stores subtotals you wish retained . . . to enter figures press appropriate key. ARITHMETIC FUNCTIONS: Adds, subtracts, multiplies, divides. Automatic constants. Chain, mixed calculations. SPECIAL KEYS, FUNCTIONS: Square root, percent keys. Performs time calculations. Memory-in-use, negative number indicators. Overflow indicator. CONSTR: Plastic body with silver color metal top measures 1 3/4 x 2 3/4 x 5 in. Operates on two AA batteries (included). ORDERING INFORMATION: Instructions included. Warranted by Casio. Write for free copy, see page 322. 3 C 58054—Shipping weight 7 ounces \$19.99



(5) Sears F-86 Slide Rule Calculator CAPACITY, MEMORY: 8-digit green light display. Fully addressable memory stores subtotals you wish retained . . . to enter figures just press appropriate key. ARITHMETIC FUNCTIONS: Adds, subtracts, multiplies, divides. Automatic constants. SPECIAL KEYS, FUNCTIONS: Percentage, square root keys, reciprocals, pi, parentheses keys. CONSTR: Gray plastic. 5x2 7/8 x 1 in. Operates on two AA batteries or AC adapter/recharger both sold separately below. Vinyl case incl. Imported. ORDERING INFORMATION: Instructions included. See 6-month warranty below. 3 C 5825—Shipping weight 4 oz. \$10.99

(6) AC adapter/recharger for (5). UL listed. 110-120-volt, 60-Hz. 3 watts. 6-ft. cord. Imported. 3 C 5839—Shipping weight 6 oz. \$3.99 Alkaline AA batteries for (5). Package of 2. 3 C 8987—Shpg. wt. 2 oz. Package \$1.19

FULL 6-MONTH WARRANTY on 3 C 5825 and FULL 1-YEAR WARRANTY ON 3 C 58041 and 3 C 5850. For the time specified from date of purchase, Sears will repair these calculators if they fail to operate properly due to defect in material or workmanship. Warranty service is available by returning calculator to any Sears store throughout the U.S. This warranty gives you specific legal rights, and you may also have other rights which vary from state to state.



A

your choice

59⁹⁹ Items A
B or C

A Computron™ is programmed for 10 entertaining and challenging games. 25,000 pre-programmed problems in workbook (incl.). Develops skills in math, spelling, words, numbers, object recognition, problem-solving logic. Correct answer wins musical salute. Auto shut-off. Abt. 11 x 7 x 5½". For one or two players aged 5-12. Uses 6 "C" batteries*, not incl.
492 541 038—English. Each 59.99

B Number Cruncher. A sophisticated electronic math quiz machine. School graded into 6 levels. 14 all math activities including quizzes with fractions, decimals. Abt. 9 x 9¼ x 6½". Ages 5 and up. Uses 6 "C" batteries*, not incl.
492 541 097—Each 59.99

C Talk Board. Interactive electronic teaching unit with English voice synthesizer. 6 x 2" color cards cover counting, math and recognition. A plastic mouse is included for 'Candy Land' game. Abt. 11¼ x 11¼ x 1¼". For ages 5 and up. Uses 6 "AA" batteries*, not included.
492 541 089—Each 59.99
Items on these two pages with
"T" in catalogue number Toronto shipped



B



C



D

D SAVE 10.00 on Electronic Whiz Kid™. Teaches music, math, spelling; includes 50 pre-programmed cards. LCD screen. Carry strap. For ages 5 and up. Uses 4 "C" batteries*, not included. Sears reg. 89.99.
492 541 041—English. Each 79.99
492 541 042 T—French. Each 79.99

E SAVE 2.00 on Whiz Kid™ Program Cartridges. Incl. 50 cards each. State no.: 01 (Numbers Fun™) or 02 (Alphabet Fun™). Sears reg. 24.99.
492 541 043 C—English. Each 22.99
492 541 044 TC—French. Each 22.99

*Batteries sold on page 398



E

SURE TO PLEASE

Christmas tree latch hook kit 16⁹⁷

A holiday craft kit is a delightful way to greet the Christmas season. Bright "Bells and Holly" kit makes for an area rug or Christmas tree skirt. Contains pre-cut olefin acrylic rug yarn plus easy-to-follow illustrated instructions. Finished size 36-inch diameter. For more decorative craft kit gift ideas see pages 286-293, this catalog. Ship. wt. 1 lb. 8 oz. 53 T 8610 16.97



ConvertaChamber day pack cut \$5 12⁹⁷

Zippered inner divider—flexibility unusual in day packs. Weatherproof 420-denier oxford nylon, leather reinforced bottom. State color no.: 010 red, 046 green, 055 navy. 17.99, Fall Bk., p. 636. Taiwan. L 60 T 71535—Ship. wt. 1 lb. . . . 12.97



Head-to-Head™ football, baseball or hockey 32⁶⁶

Head to Head Electronic Football—plays against computer or opponent! Offense runs, passes, blocks and kicks. Defense tackles and intercepts. Large display, sounds, 2 skill levels. Uses one 9-V battery (not included; order from page 483). AGES: 8 up. More electronic games, pgs. 480-491.

48 T 14580—Wt. 8 oz. 32.66*
48 T 14582—Head to Head Hockey. Wt. 8 oz. 32.66*

Save \$10 when purchased with Ray-O-Vac batteries, see pg. 484.

Head to Head Electronic Baseball. For 1 or 2 players. Can steal, bunt, have double-plays, power hits, extra innings. 2 skill levels. LED's track ball, men on base. Two 9-V batt. (not incl.; order pg. 483). More games pgs. 480-491. 48 T 14054—Wt. 15 oz. AGES: 8 up. 32.66*

*See pg. 484 for information on how to save \$10 when purchased with Ray-O-Vac batteries.



Four-piece football outfit 17⁹⁹

Picture your future football player in this! You can even add his name to the jersey with our lettering kit (sold below). Outfit: one-piece plastic helmet with double face bar and chin strap, medium weight jersey, white twill pants (padded at thigh and knee), elastic waist, fibermolded shoulder pads. Not recommended for contact play. State waist: S(22-24), M(26-28), color no.: 10 red, 50 blue. More sporting goods pgs. 442, 443. B 60 T 23263—Wt. 6 lbs. 6 oz. . . . 17.99
IRON-ON KIT. 5/8-in. numerals, 1 3/4-in. letters for jersey or helmet. 60 T 23263—Ship. wt. 8 oz. 3.99

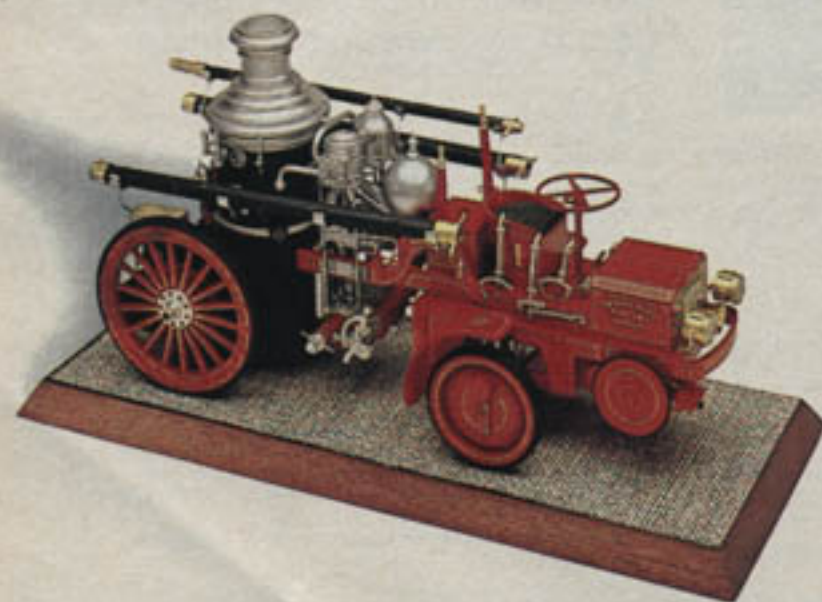

"The Christie"—Turn-of-the-century steam fire engine model kit 19⁹⁷

"The Christie"—1911 American steam fire engine was the cause of excitement as it raced through the streets of San Francisco at 18 mph! History repeats itself in this handsome 1/25 scale replica with detailed engine, drive train and working steering. Has over 400 parts fully molded in color, plus decals, brass and chrome plated pcs. AGES: 10 up. More kits page 461.

14 WARDS ALL 48 T 17407—18 in. long. Ship. wt. 2 lbs. 19.97



Lovable, comical Fun Around Faces™ 14⁴⁴

A puzzle delight for pre-schoolers as they fit comical face making parts into place. As crank is turned eyes go round, lips move, plus other zany action. Built-in storage, 23 parts, 4 face mats. More pre-school toys, pgs. 418-430.

48 T 15351—Ship. wt. 2 lbs. 8 oz. 14.44



Westbend® 1-4 cup Hot 'n Handy™ pot 16⁹⁵

Portable instant cooker for hot foods, beverages. Use at home, in the office, outdoors camping! Non-stick, lock-on lid, pouring spout. More appliances, pgs. 272-274.

86 T 45890—Wt. 2 lbs. 2 oz. . . . 16.95

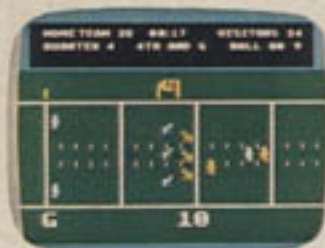

Football



Pole Position



Pitstop



Temple of Apsahai



Gyruss

Atari computer programs for entertainment, education and personal finance/productivity

Title**	Format	Description	Catalog number	Ship. wt.	Price each
Atari computer entertainment software programs					
Dig Dug	Cartridge	Burrow underground to escape fire-breathing dragons.	62G40000	9 oz.	42.99
Donkey Kong	Cartridge	Help Mario save his girl in this arcade classic.	62G1501	9 oz.	44.99
Donkey Kong Jr.	Cartridge	Jr. pursues Mario through the jungle to save his papa!	62G1505	9 oz.	44.99
Real Sports Football	Cartridge	Control players, formations and plays in real time.	62G1506	9 oz.	44.99
Joust	Cartridge	Duel the bird-riding gladiators just like the arcade game.	62G1504	9 oz.	44.99
Jungle Hunt	Cartridge	Survive jungle perils to save your sweetie from the savages.	62G40001	9 oz.	44.99
Mario Brothers	Cartridge	Third generation in the Donkey Kong series.	62G40002	9 oz.	44.99
Ms. Pac Man	Cartridge	Guide the First Lady of the arcades through multiple mazes.	62G1502	9 oz.	44.99
Pengo	Cartridge	"Make your own maze" game with adjustable skill levels.	62G40003	9 oz.	44.99
Pole Position	Cartridge	Ultra-realistic graphics and sound of the Grand Prix.	62G1503	9 oz.	44.99
Centipede	Cartridge	Blast the centipede and his equally creepy companions.	62G1500	9 oz.	42.99
Archon	Disk	Dazzling medieval fantasy game with the strategy of chess.	62G40004	9 oz.	32.99
Pinball Construction Set	Disk	Make your own pinball games in an infinite variety of ways.	62G40005	9 oz.	32.99
Choplifter	Cartridge	Guide your craft through the enemy's defenses to the rescue.	62G40006	9 oz.	39.99
Pitstop	Cartridge	The only road race game where winning is in the pits.	62G40007	9 oz.	39.99
Temple of Apsahai	Disk	Fantasy role-playing game in the Dungeons & Dragons tradition.	62G40008	9 oz.	39.99
Temple of Apsahai	Cassette	Fantasy role-playing game in the Dungeons & Dragons tradition.	62G1512	9 oz.	39.99
Computer War	Cartridge	Simulation program based on the hit movie "War Games."	62G1508	9 oz.	32.99
Star Wars Arcade Game	Cartridge	Penetrate your opponent's defenses and become a Jedi Master.	62G40009	9 oz.	42.99
Starbowl Football	Cassette	Realistic gridiron action from college to pro levels.	62G1511	9 oz.	24.99
Gyruss	Cartridge	Conquer planets from Neptune to the safe haven Earth.	62G40010	9 oz.	42.99
Q-bert*	Cartridge	Bounce from cube to cube avoiding the cast of loony characters.	62G1509	9 oz.	42.99
Star League Baseball	Cassette	Play features 2 screens and up-to-date stats on all the action.	62G40011	9 oz.	24.99
Frogger	Disk	Guide your frog through traffic and alligator-infested streams.	62G40012	9 oz.	29.99
Frogger	Cassette	Guide your frog through traffic and alligator-infested streams.	62G1510	9 oz.	29.99
B.C. Quest for Tires	Cartridge	Travel through the world of cartoon character "B.C."	62G40013	9 oz.	32.99
Blue Max	Disk	Control a World War I biplane in battle in 3-D.	62G40014	9 oz.	29.99
Blue Max	Cassette	Control a World War I biplane in battle in 3-D.	62G40015	9 oz.	29.99
Castle Wolfenstein	Disk	Your mission is to locate plans for a German offensive.	62G1507	9 oz.	24.99
Zaxxon	Disk	3-D game where you destroy enemy installations.	62G40016	9 oz.	32.99
Zaxxon	Cassette	3-D game where you destroy enemy installations.	62G40017	9 oz.	32.99
Zork I	Disk	The first in the Zork series of text adventure games.	62G40018	9 oz.	32.99
Zork II	Disk	Part 2 of the thought provoking trilogy.	62G40019	9 oz.	32.99
Zork III	Disk	The classic underground trilogy of thought-provoking fun.	62G40020	9 oz.	32.99
Enchanter	Disk	Fate has chosen you to combat the dark and fierce power.	62G40021	9 oz.	39.99
Sargon II	Cassette	Play chess against the champion of computer chess games.	62G40022	9 oz.	24.99
Astro Chase	Disk	Defend Earth from aliens. Great graphics, scrolling, audio.	62G40023	9 oz.	24.99
Astro Chase	Cassette	Defend Earth from aliens. Great graphics, scrolling, audio.	62G40024	9 oz.	24.99

Title**	Format	Description	Catalog number	Ship. wt.	Price each
Atari computer educational software programs					
Invitation to Programming 2	Cassette	Get on your way to becoming fluent in basic language.	62G40025	9 oz.	24.99
Invitation to Programming 3	Cassette	Use color registers and graphic characters to make art.	62G40026	9 oz.	24.99
Conversational Spanish	Cassette	Learn a wealth of words and phrases with picture aids.	62G40027	9 oz.	54.99
Atari Logo	Cartridge	Enhance math and language skills.	62G40028	9 oz.	89.99
Mastertype	Cartridge	Increase typing skills while having fun.	62G40029	9 oz.	32.99
Delta Drawing	Cartridge	Draw, color and learn computer programming concepts.	62G40030	9 oz.	32.99
Alphabet Zoo	Cartridge	Teach your children the relationship between letters and sounds.	62G1513	9 oz.	29.99
Facemaker	Cartridge	Create your own funny face and watch it come to life.	62G1515	9 oz.	29.99
Fraction Fever	Cartridge	Action game that develops an understanding of fractions.	62G1514	9 oz.	29.99
Kids on Keys	Cartridge	Use letters, numbers and pictures to introduce the keyboard.	62G40031	9 oz.	29.99
Kindercomp	Cartridge	Five games in one to improve reading and counting skills.	62G40032	9 oz.	29.99
Reading Comprehension	Cassette	Select the word that doesn't belong in the series.	62G40033	9 oz.	12.99
Alphabet Arcade	Cassette	Put letters and selected words in alphabetical order.	62G40034	9 oz.	12.99
Preparing for the S.A.T.	Disk	Prepare for the aptitude test!	62G40035	9 oz.	99.99

Title**	Format	Description	Catalog number	Ship. wt.	Price each
Atari computer personal finance/productivity software programs					
Atari Writer	Cartridge	Advanced word processor handles family writing needs.	62G40036	9 oz.	89.99
Family Finance	Disk	Track income, expenses, establish goals and track your progress.	62G40037	9 oz.	44.99
VisiCalc	Disk	Money question? See the bottom line impact before it happens.	62G1517	9 oz.	179.99
Bank St. Writer	Disk	Word processing program for both novice and experienced users.	62G1519	9 oz.	59.99
Home Financial Mgmt.	Cassette	Plan and control your own budget by tracking various categories.	62G1518	9 oz.	24.99
Home Accountant	Disk	Keeps track of 200 plus budget categories for home or business.	62G40038	9 oz.	64.99
Tax advantage	Disk	Perform all calculations, worksheets and entries for your taxes.	62G40039	9 oz.	59.99
Mailing List	Cassette	Store, file and print names, addresses and phone numbers.	62G40040	9 oz.	24.99

NOTE: Disk software requires disk drive (21113, key B) sold on page 523. Cassette software requires program recorder (21103, key F) sold on page 523. Cartridge software does not require storage, but we recommend the use of joysticks and trackballs sold, pg. 532.

**Write for a free copy of Manufacturer's Warranty, see page 497.

See page 523 for the Atari 800 XL computer and Atari peripherals.



Mario Bros.



Archon

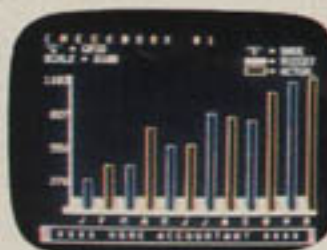

Home Accountant



Alphabet Zoo



Kindercomp



Atari Writer

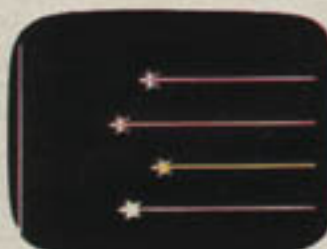

Atari Logo

The Atari® 7800 game system brings home arcade-quality graphics and controls!



- ✓ Handles high-resolution 7800 Super Series cartridges, and plays all 2600-series cartridges
- ✓ 2 Pro-Line joystick controllers for responsive action
- ✓ Includes Pole Position II game cartridge

\$89⁹⁹

2 Let yourself go with the premium graphics of Atari's™ 7800 system. Versatile system plays the most advanced arcade hits such as *Ms. Pac Man™*, *Joust™* and *Asteroids™* while also handling great games from the 2600 game system (sold below). Order additional cartridges listed below and at right (as well as 2600 games sold below). Plays on black and white or color TVs. UL listed. Warranted by Atari*. For ages 8 years and up. 49 N 65941—Wt. 6 lbs. 12 oz. . . \$89.99

7800-series video game cartridges below and at right have improved graphics for more realistic game play. Warranted by Atari.* Wt. 5 oz.

Cartridge Name	Catalog Number	Price
Asteroids™	49 N 65945	\$17.99
Centipede™	49 N 65944	17.99
Choplifter™	49 N 65819	17.99
Food Fight™	49 N 65823	17.99

3 The joystick that's called TAC-2 . . . for Totally Accurate Controller! And that's just what it is. Two fire buttons let you use joystick with your left or right hand. Durable unit features arcade styling and ball handle. Extra-long 5½-foot cord. Warranted by manufacturer*. 49 N 65872—Wt. 14 oz. . . \$12.99

*Write for free copy, see page 304.



Ball Blazer™
49 N 65732 . . . \$24.99

Desert Falcon™
49 N 65811 . . . \$24.99



Hat Trick™
49 N 65734 . . . \$24.99



Joust™
49 N 65826 . . . \$17.99



Karateka™
49 N 65812 . . . \$24.99



One-on-one Basketball™
49 N 65817 . . . \$24.99



Summer Games™
49 N 65803 . . . \$34.99



Winter Games™
49 N 65805 . . . \$34.99

The popular Atari® 2600 game system is small and portable for fun-filled action wherever you go! \$49⁹⁹



4 The Atari® 2600 system plays a huge assortment of Atari® game cartridges. Small size allows portability for active use. Includes one joystick. Plays on color or black and white TVs. Order game cartridges at right. Warranted by Atari*. UL listed. For ages 8 years and up. 49 N 65932—Wt. 3 lbs. . . \$49.99

Game cartridges below and at right have clear and entertaining graphics for fun-filled play. Can also be played on 7800 system (2) sold above. Wt. 5 oz.

Cartridge Name	Catalog Number	Price
Centipede™	49 N 65736	\$14.99
Donkey Kong™	49 N 65737	14.99
Q*Ber™	49 N 65738	14.99
Jungle Hunt™	49 N 65739	14.99
Moon Patrol™	49 N 65743	14.99
Joust™	49 N 65744	14.99
Football™	49 N 65938	14.99
Tennis™	49 N 65745	14.99
Kangaroo™	49 N 65713	14.99

5 Extra joystick attaches to your Atari® 2600 system for second player. Includes non-skid feet. Warranted by manufacturer*. 49 N 65857—Wt. 8 oz. . . \$6.99

<p>Baseball™</p> <p>Baseball™ 49 N 65746 . . . \$14.99</p>	<p>Boxing™</p> <p>Boxing™ 49 N 65749 . . . \$17.99</p>	<p>Crossbow™</p> <p>Crossbow™ 49 N 65747 . . . \$17.99</p>
<p>Crystal Castle</p> <p>Crystal Castle 49 N 65934 . . . \$17.99</p>	<p>Mario Bros. 2600™</p> <p>Mario Bros. 2600™ 49 N 65748 . . . \$17.99</p>	<p>Midnight Magic</p> <p>Midnight Magic 49 N 65937 . . . \$17.99</p>

Extra Cartridges
for RCA Studio II

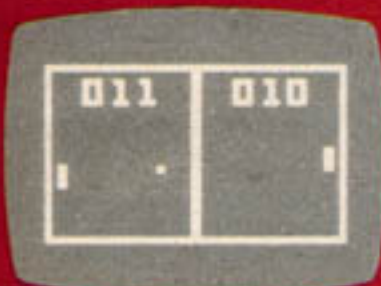

Tennis/Squash



Space War



Fun with Numbers



School House



Baseball



Blackjack



Math Fun



Mattel Auto Race simulates the suspense of racetrack competition in a hand-held unit the size of a mini-calculator! Take it to the beach or in your car—no TV set or household current needed. Electronic display shows autos in three lanes racing against a 99-second digital clock. You operate controls to steer and shift gears in a four-lap race. Avoid collisions with other autos. Collision makes your car lose time. You hear a sound signalling victory from built-in speaker. Durable plastic case is compact, pocket-size—1x3x5 in. Uses 9-volt battery (not incl., order on page 360). Warranted by manufacturer, see page 336. X 917-2180 A—Mailing weight 0.50 lb. 19.95

Mattel Football Game. Just the thing for any sports fan—a football stadium as near as your jacket pocket! Here's hours of amusement as you try to outscore your opponent within the designated playing time. The action is absorbing as light-blip players scamper across the turf. You're the ball carrier, facing a squad of rushing tacklers. Cut back! Speed up! Avoid being tackled! Run for daylight and score a TD. Built-in speaker puts out a sound effect for "Charge!" Automatic scoreboard shows downs, yardline, yards to go, time remaining, and home/visitor score. You maneuver the running back with directional controls; if running back collides with a tackler, he's down. Uses 9-volt battery (not incl., order on p. 360). Plastic case measures 1x3½x6 in. Warranted by manufacturer, see p. 336. X 917-2198 A—Mailing weight 0.50 lb. 29.95

Mini Computer
Games from
Mattel Electronics

a great gift value

BECAUSE

- Game action is displayed on built-in screens—no TV needed
- Battery-operated units are self-contained, pocket size—travel anywhere
- Sound effects emit from built-in speakers

AND PRICED AT ONLY

19⁹⁵ | 29⁹⁵
Auto Race | Football

Use your **JCPenney Charge Account** for Regular Charge and Time Payment purchases—see pages 340-342

More cartridges
for your

ATARI 5200



Centipede



Football



Star Raiders



Missile Command



Galaxian



Defender



Tennis



CounterMeasure



Space Invaders

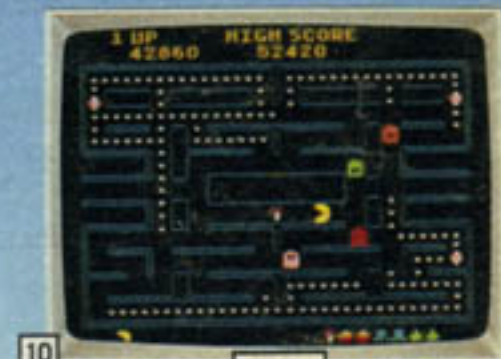

Pac-Man

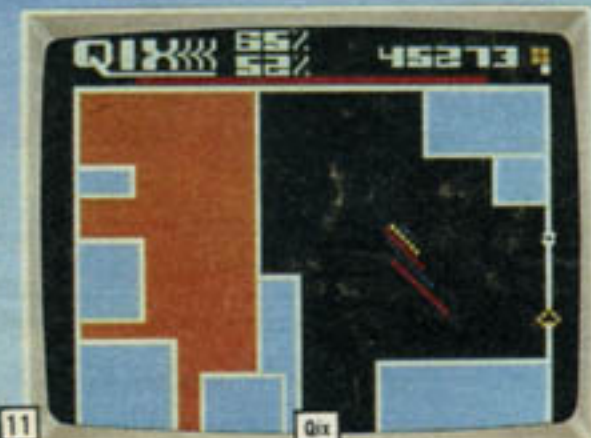

Qix



Soccer

(1 thru 12) When necessary cartridges include control-customizing keypad overlay for easy on-screen maneuvering and game-play booklet. Convenient overlay storage slot in each cartridge case. Warranted by Atari, see p. 323. Wt. 4 oz. ea.

Cartridge name and description	Catalog No.	Price
(1) Centipede. Each time you hit the creepy crawly, it divides and all sections come after you! 1 or 2 players.	49 C 75865	\$39.99
(2) Football. Set up intricate play action, offense or defense. Player to player ball control. 1 or 2 players.	49 C 75863	31.99
(3) Star Raiders. Monitor your space ship's radar, tracking, shields and maps... hyperwarp into battle. 1 or 2 players.	49 C 75861	39.99
(4) Missile Command. Defend cities from aliens with anti-ballistic missiles. Colors light up the screen when you hit the enemy. 1 or 2 players.	49 C 75859	31.99
(5) Galaxian. It's your lone ship against a fleet of aliens flying down in formation to attack you. 1 or 2 players.	49 C 75858	39.99

Cartridge name and description	Catalog No.	Price
(6) Defender. Destroy attacking aliens before they kidnap your friends and turn them into mutants. 1 or 2 players.	49 C 75866	\$39.99
(7) Tennis. Rush the net, lay back, play the baseline or roam the court with real club finesse. Your serve! 1 or 2 players.	49 C 75867	31.99
(8) CounterMeasure. Tough tank combat on a variety of terrains. 1 or 2 players.	49 C 75868	31.99
(9) Space Invaders. Strange aliens march down to destroy you. Blast them with your laser cannon. 1 or 2 players.	49 C 75856	31.99
(10) Pac-Man. Arcade-quality graphics and real pac-mania action. Bonus fruit and more! 1 or 2 players.	49 C 75857	39.99
(11) Qix. Corner the Qix into a small corral before it or the Super Sporz touch you. 1 or 2 players.	49 C 75869	31.99
(12) Soccer. The fastest runners and goalies compete for the World Cup Title and you're the coach! 1 or 2 players.	49 C 75864	31.99

choose from 31 cartridges, over 370 games

Console attaches directly to TV . . . turns it into an action-packed arcade of sport, space, battle and educational games

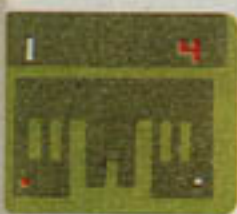

For 1 or 2 players . . .
9 playfields, 2 games
on 9-hole 36-par course

Compete at miniature golf for low score. Computer records strokes and advances play to next hole. Each of 9 playfields feature unique obstacles, including moving obstacle to test your skill.
ORDERING INFO: Uses joystick controls.
6 C 99829—Shipping weight 4 oz. . . . \$19.95



For 1 or 2 players . . .
4 playfields
for 17 games

Guide your command module through space combat and delicate docking maneuvers. Score hits to 10 points or until time, "fuel" supply, or "missiles" run out; avoid gravitational sun.
ORDERING INFO: Uses joystick controls.
6 C 99812—Shipping weight 4 oz. . . . \$19.95



For 1 or 2 players . . .
5 playfields for 16
games to 99 points

Two gunslingers face off in "street", run in, step back, move up and down, sit down when shot. Add six-shooters, cactus, wall or stage coach for extra challenge. Shooting sound effects.
ORDERING INFO: Uses joystick controls.
6 C 99822—Shipping weight 4 oz. . . . \$19.95

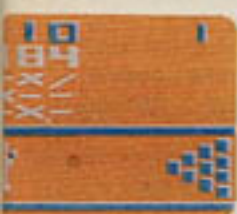

For 1 or 2 players . . .
1 playfield for 6
games of 10 frames

Control your bowler's approach and delivery of the ball down the lane toward the pins. Strikes, spares, and open frames are scored and displayed. Choose curve, steerable or straight ball.
ORDERING INFO: Uses joystick controls.
6 C 99842—Shipping weight 4 oz. . . . \$19.95



For 1 or 2 players . . .
3 playfields
for 17 games

You, the astronaut, fly through 2-dimensional star-studded space trying to draw your opponent within laser-range using your force field. Score points for a hit, lose points for asteroid collisions.
ORDERING INFO: Uses joystick controls.
6 C 99803—Shipping weight 4 oz. . . . \$19.95



For 1 or 2 players . . .
1 playfield
for 8 games

Bet up to 25 "coins" in three-wheel, twenty-stop Las Vegas-style slot machine featuring both jackpot and payoff games. Game ends when either player or computer "goes broke".
ORDERING INFO: Uses joystick controls.
6 C 99823—Shipping weight 4 oz. . . . \$19.95



For 2 players . . .
1 playfield for 3 games
5 formations

Choose offense: run, punt, or steer pass. Computer starts clock, play action, records scores, indicates possession and advances first-down marker, your defense can tackle or intercept.
ORDERING INFO: Uses joystick controls.
6 C 99827—Shipping weight 4 oz. . . . \$19.95



For 2 players . . .
5 playfields for 27
games up to 99 points

Fire your tank's cannon and score points when you hit your opponent's tank. Fly a W.W.I. bi-plane fighter with machine guns or be a jet ace with guided missiles.
ORDERING INFO: Uses joystick controls.
6 C 99801—Shipping weight 4 oz. . . . \$19.95

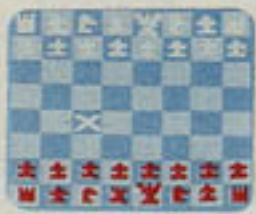

For 1 player . . .
one playfield for
8 skill levels

Computer ability ranges from novice to skilled player; acknowledges castling, en passant moves, pawn promotion. You determine skill level, and can set up board to simulate situations.
ORDERING INFO: Uses joystick control.
6 C 99817—Shipping weight 4 oz. . . . \$39.95



For 1 or 2 players . . .
2 playfields for 8
games, score to 7 hits

Compete for high score by shooting cannon man into water tower. Adj. cannon elevation, cannon distance from tower, flight speed of cannon man in order to succeed, or let computer choose.
ORDERING INFO: Uses joystick controls.
6 C 99841—Shipping weight 4 oz. . . . \$19.95



For 1 or 2 players . . .
3 playfields for 14
games to 10 points

Force your opponent to steer his track into one already laid. Steer leader block across and even off screen; speed up, move diagonally, erase blocks, or "write" on screen with Graffiti.
ORDERING INFO: Uses joystick controls.
6 C 99807—Shipping weight 4 oz. . . . \$19.95



For 1 or 2 players . . .
one playfield
for 8 games

Play backgammon-acey deuce; set up board to simulate situations, dial in your own dice numbers and accept or reject doubling. Computer will withdraw if it rejects doubling by the player.
ORDERING INFO: Uses joystick controls.
6 C 99848—Shipping weight 4 oz. . . . \$39.95



For 1 or 2 players . . .
one playfield for 5
games to 99 points

Guide your parachutist to landing pad; score points depending on when chute is opened. Computer controls wind direction, speed, position of pads, and deducts points for chute failure.
ORDERING INFO: Uses joystick controls.
6 C 99843—Shipping weight 4 oz. . . . \$19.95



For 1 or 2 players . . .
one playfield
for 10 games

Find hidden flag on 63-square grid; computer gives you directional arrows, clues. But beware; step on a hidden bomb and go back to start! Vary game with timed play or moving flag options.
ORDERING INFO: Uses joystick controls.
6 C 99824—Shipping weight 4 oz. . . . \$19.95



For 1 or 2 players . . .
8 playfields for 14
games, controls included

Control direction, speed of car through turns, down straightaways. Race, crash sound effects. Games incl. Ice Race, Tag, and Crash N' Score.
ORDER INFO: Drive controls incl.; 48-in. cords plug into your console. 360° turning radius.
6 C 99821—Shipping weight 12 oz. . . . \$39.95



WISH BOOK
VALUE

New at Sears!

Ms. Pac-Man
REBATE
from Coleco
\$10

Donkey Kong and Pac-Man
Save a total of **\$25** *New at Sears!*
Cut \$15 plus \$10
rebate from Coleco

Q*bert
REBATE from
Parker Bros.
\$7

(1) Ms. Pac-Man™ has 2 game variations. 8 complex mazes plus 2 skill levels. Play against the computer or play a friend. Special fruit bonuses for extra challenge. Records and displays best score. Plastic, 7¼x6¼x8¼ in. high housing. Requires 4 "C" batteries, not included, sold below. Warranted by Coleco, see page 323. \$34.99 after Coleco rebate... see p. 545.

Ages 8 years and up. Wt. 2 lbs.
49 C 65125..... Full Price \$44.99
49 C 65122—Adapter for (1) thru (3)

(2) Donkey Kong™ has 3 games in one! It's man against ape, each in an entirely different situation. The higher you score, the harder the game. Records and displays best score. Plastic, 7¼x6¼x8¼ in. high housing. Requires 4 "C" batteries or adapter, not included, sold below. Warranted by Coleco, see page 323. Was \$59.99 in our 1982 Wish Book, p. 3. \$34.99 after Coleco rebate... see p. 545.

Ages 8 years and up. Wt. 2 lbs.
49 C 65117..... Full price \$44.99
UL listed for 110-120-volts, 60 Hz., AC. Shipping weight 8 ounces

(3) Real Pac-Mania... 3 games in one! Play Pac-Man against the computer, against a friend or play the timed challenge, Eat & Run. Records and displays best score. Plastic, 7¼x6¼x8¼ in. high housing. Requires 4 "C" batteries or adapter, not included, sold below. Warranted by Coleco, see page 323. Was \$59.99 in our 1982 Wish Book, p. 636. \$34.99 after Coleco rebate... see p. 545.

Ages 8 years and up. Wt. 2 lbs.
49 C 65115..... Full price \$44.99
Shipping weight 8 ounces..... 9.99

(4) Q*bert plays like the arcade game. On the same 3-D pyramid there's bouncing balls, Coily the Snake, Slick, and Ugg. Even the floating escape disc. 1 player. Plastic, 7½x5½x5½ in. high housing. Requires 4 "C" batteries, not included, sold below. Warranted by Parker Bros., see p. 323. \$49.99 after Parker Bros. rebate... see page 545. Ages 7 to 15 years. 49C65715—Wt. 2 lbs. Full price \$56.99

DieHard "C" Batteries. Package of 2
49 C 30929—Wt. 5 oz. ... Pkg. \$2.39

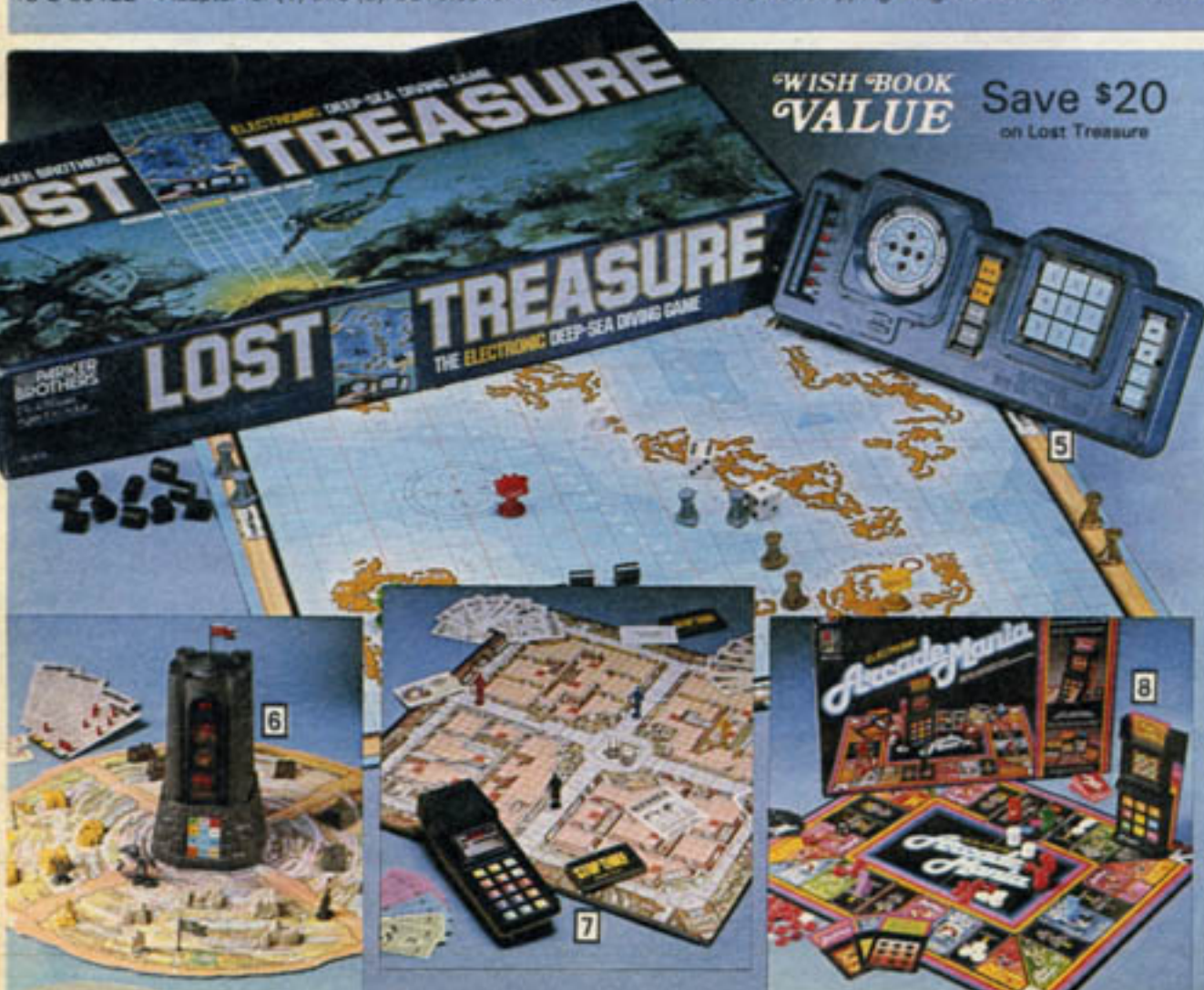

WISH BOOK
VALUE Save \$20
on Lost Treasure

ELECTRONIC BOARD GAMES

(5) Dive for Lost Treasure™... electronic sonar scanner uncovers clues; dive simulator keeps track of oxygen supply. 2 to 4 players. Plastic board. Requires one 9-volt battery sold on facing page. Warranted by Parker Bros., see 323. Was \$34.99 in 1982 Wish Book, p. 635.

Ages 8 yrs. to adult. Wt. 2 lbs. 15 oz.
49 C 65738..... Now \$14.99

(6) Capture the Dark Tower of electronic wizardry. The computer decides the results of each move. Search for the 3 keys to enter the tower. 1 to 4 players. Plastic play pieces. Requires 2 "D" batteries, sold on facing page. Warranted by Milton Bradley, see p. 323.

For ages 10 years to adult.
49 C 65416—Wt. 5 lbs. 4 oz. ... \$46.99

(7) Stop Thief®... electronic cops and robbers. A crime has been committed. Use electronic clues to catch the culprit. 2 to 4 players. Plastic pieces. Requires one 9-v. battery, sold on facing page. Warranted by Parker Bros., see p. 323. \$24.99 after Parker Bros. rebate... see page 545.

Ages 10 yrs. to adult. Wt. 2 lbs. 15 oz.
49 C 65729..... Full price \$34.99

(8) Never a dull moment with Arcade Mania. Collect chips thru strategic board moves and skillful head-to-head arcade playing. Multiple skill levels. 1 to 4 players. Requires 6 "AA" batteries, sold on facing page. Warranted by Milton Bradley, see p. 323.

For ages 8 years and up.
49C65411—Wt. 14 lbs. 13 oz. ... \$29.99



1
6³³

They're safe!
The Velcro® ball darts
have no points, but
they sure stick!



3
One-On-One
Basketball
shoot—block—score
12⁷⁷



MARX
TV Tennis 4
17⁸⁸



2
9⁸⁴

Sleep
Walker
he's a
corker!



He moves by himself—but to
score you have to guide him
so he doesn't fall



Top Ten Fun Games—
something for
everyone 5
6⁹⁹



7
Trap Tennis—
it takes skill
and timing to score
6⁷⁷



Nutty
Tennis
7⁹⁵



Hit-N-Run Pinball
12⁹⁸



Spike Shot Volley Ball
Volley 10
7⁸⁹

Up 'n' On
Sports Center
8 games in one!



9
7⁹⁹

puck slides
up and over end
of board to score

394 JCPenney



STEREO

television at
fabulous
savings

\$1199 save \$300
UNTIL DEC. 21, 1987

A Better clear some room under the tree for this beauty... a full 28" of color with stereo sound! A 24-button remote control puts you in charge. Built-in converter and stereo decoder. On-set channel up/down and scan. On-screen time/channel, timer, A/V mode and digital control. Off timer—no more waking up to test patterns. Quartz crystal tuning for a clear, sharp picture. Sharpness control, auto program and light sensor. Comb filter. Four speakers let you enjoy full rich stereo sound; treble, bass and balance controls. 2 audio/video inputs, 2 audio outputs. External speaker. About 27" wide x 19" deep x 25½" high.
After December 21, 1499.00.
572 514 267 DLJN—Until December 21, each . 1199.00



save \$100 UNTIL DEC. 21, 1987

B All the features you want in a 20" color set including great sounding built-in stereo. Built-in converter. 20-button remote control puts it all at your fingertips. Channel scan on set. Sharpness control, tone control and quartz crystal tuning for excellent picture quality. Comb filter. One-button color. On-screen channel/time, timer and A/V mode. Dual speakers for great stereo sound. A/V input, audio output, external speaker jacks. Measures about 25" wide x 20" deep x 18" high.
After Dec. 21, 849.99.
572 514 947 DLJN—Until December 21, each 749.99



A

24.99

B

24.99

C

19.99

D

14.99



Less than 1/4" thick, credit-card size!

Liquid crystal display

Calculators... gifts you can count on

NS100L Billfold calculator

- 4-key accumulating memory; automatic shut-off
- Fits neatly into its own wallet, complete with ball-point pen, credit-card holder and note pad

A 8-digit L.C.D. calculator with 4-key accumulating memory, automatic shut-off after 7 minutes of no operation (saves battery). Does basic +, -, x, ÷ functions plus square root. Gives up to 2500 hours of service off two 1.5-volt silver oxide batteries (included). Abt. 4 1/2 x 2 3/4 x 3/16"; 4 1/2 oz.

032 541 549—Each 24.99

Canon LC8M pocket calculator

- Bright 8-digit display; large, easy-to-use keys
- Extra-long battery life, up to 4000 hours

B Automatic % key with add-on and discount capability. 8-digit L.C.D. with floating decimal, accumulating memory, square root, automatic constant. Also does basic +, -, x, ÷. Uses two 'AAA' batteries (included). Brown vinyl billfold case. About 2 3/4 x 5 x 7/16"; weighs about 6 oz.

032 541 510—Each 24.99

Sears 2003 SuperThin

- Credit-card size... fits easily into pocket or purse
- Full accumulating memory; automatic % key

C An incredibly small unit with many big-machine features: large 8-digit L.C.D. with floating decimal; indicators for memory-in-use, negative numbers, errors. Auto % with add-on and discount capability, automatic constant, automatic shut-off after 7 minutes of no operation (saves battery), basic +, -, x, ÷, 400-hr. battery life using 2 G10 alkaline batteries (included). Vinyl carry pouch. About 3 1/2 x 2 1/8 x 7/16"; 3 oz.

032 541 547—Each 19.99

Save \$3 Sears 2000 L.C.D.

- Automatic shut-off after 7 minutes of no operation
- 8-digit display, 2500 hours of battery life

D A slim basic calculator with full accumulating memory, auto % key with add-on and discount capability, automatic constant; does basic +, -, x, ÷. Uses two 1.5-volt silver oxide batteries (not included, sold on Page 335, Cat. no. 032 523 005). Vinyl carry pouch. Abt. 4 1/2 x 2 3/4 x 7/16"; 6 oz.

032 541 540—Regularly 17.99. Each 14.99

Save \$10

The Datachecker™... three memories you can bank on! **39.98**

- 3 continuous memories retain data even when unit is off—give an 'instant statement' when you need it
- Up-to-the-minute balance on cheque book plus 2 other accounts... or use as full memory calculator

E Just key in the debits and credits of each account and the Datachecker shows how much you've paid or spent—even has a grand-total key that gives the sum of all three accounts. Use it with floating decimal or add-mode (which automatically adds in dollars and cents); use it as a calculator—it has +, -, x, ÷, % key with add-on and discount capability. Easy-to-read 8-digit liquid crystal display. Battery life of about 1300 hours—two 1.5-volt silver oxide batteries included. With Gold color pen and cheque-book case (cheques not incl.). 6 x 2 3/4 x 7/16"; 6 oz.

032 541 535—Regularly 49.98. Each 39.98



E

A 337



1 and 2 \$5 less thru December 15th. The NBA's most valuable player takes time out on your wrist! These Time Jordan® quartz analog watches have the same precision as Michael. Second hand. Plastic case and strap. Imported. Warranted by Excelsior*. Wt. 3 oz.

Style	Catalog No.	Thru 12/15	After 12/15
(1) Small round dial	T 4 E 19504	\$24.99	\$29.99
(2) Large round dial	T 4 E 19503	24.99	29.99

3 thru 6 Plastic game watches with digital time displays. Imported. Warranted by Nelsonic*. Enlarged to show detail.

3 Pac-man™ game watch has an alarm.
4 E 45461—Wt. 3 oz. . . \$19.99

4 Soccer game watch lets you feel like you're right on the field.
4 E 45644—Wt. 2 oz. . . \$15.99

5 Q*bert® game watch . . . help him travel from one cube to another. Sound effects.
4 E 45641—Wt. 3 oz. . . \$19.99

6 Become a driving ace with the car game watch.
4 E 45577—Wt. 3 oz. . . \$15.99

7 and 8 Keep time with your favorite team! Choose from these officially licensed NFL names and insignia:

105-Browns	111-Raiders	122-Giants
106-Broncos	115-Bears	125-49'ers
109-Dolphins	116-Cowboys	126-Redskins
110-Jets	119-Rams	127-Seahawks

7 Authentic replica of NFL helmet houses a quartz digital alarm clock. Nightlight for easy reading. 3½x3¼x4 inches. Plastic. Requires one "AAA" battery not included. Imported. Warranted by Welby*. State team number from above.
T 4 E 74221H—Wt. 4 oz. . . \$16.99

8 NFL helmet watch snaps up for digital time display and date. Plastic with removable Velcro® band. Imported. Warranted by Fremark International*. State team number from above.
T 4 E 45585H—Wt. 2 oz. . . \$9.99

9 Youth's mechanical analog watch with color nameplates for all 28 NFL teams. Black plastic case and vinyl strap. Imported. Warranted by Welby*.
T 4 E 18765—Wt. 2 oz. . . \$16.99

10 Youth's quartz digital watch comes with full color dials for all 28 NFL teams. Time display, date and 15-minute stop watch timer. Plastic case with vinyl strap. Imported. Warranted by Welby*.
T 4 E 45569—Wt. 2 oz. . . \$9.99

11 Pee Wee Herman™ plastic digital watch. For a big adventure, lift Pee Wee's head and find the time! Imported. Warranted by Nelsonic*.
4 E 45571—Wt. 3 oz. . . \$9.99

12 The California Raisins™ plastic digital watch. Lift the raisin for the time display. Imported. Warranted by Nelsonic*.
4 E 45570—Wt. 3 oz. . . \$6.99

Let us be your Santa . . . we'll deliver your gifts to home or office for just a little more than store pick-up for mailable orders



13 Digital commando time! Water-resistant** watch with compass that slides off band. Pop out dial with three interchangeable plastic straps. Plastic case. Imported. Warranted by Quintel*.
4 E 45564—Wt. 3 oz. . . \$5.99

14 All time teacher set. Includes mechanical analog watch, time setting clock and All time story book. Metal watchcase. Imported. Warranted by Nelsonic*.
4 E 45569—Wt. 3 oz. . . \$17.99

* Write for free copy, see p. 304.
** See water resistant note on p. 86.
▲©1981 Ball Midway Mfg. Co.
†©1982 Gottlieb Co./Columbia Pictures
©Herman Toys Inc. All rights reserved
■©1988 Calrab. Licensed by Applause
▲©1987 Alien Productions

Catalog numbers with a "T" prefix may take extra time for delivery



APPLE IIe/c-COMPATIBLE LASER 128

Gives you access to one of the largest software libraries in existence

Save on computer combinations! See page 617.

The Laser 128 has a built-in 5¼-in. disk drive and 80-column display. 128K RAM memory expands to 1 megabyte. Built-in RGB/composite color and monochrome video outputs. Built-in serial, parallel, modem, and mouse/joystick ports. One Apple-compatible expansion slot. Warranted.** Imported.

3 E 32100L—Wt. 16 lbs. . . \$399.99

Laser 128 EX is similar to (1) but has three-speed processor (1, 2.3, 3.6 MHz), 192K RAM (128 user RAM; 64K video RAM) expandable to 1000K.

3 E 32102C—Wt. 15 lbs. . . \$499.99

5¼-in. external drive for (1), Laser 128 EX (not shown).

3 E 32101—Wt. 5 lbs. . . \$149.99

Apple IIe/c-compatible mouse (not shown) for (1) and Laser 128 EX.

3 E 32190—Wt. 13 oz. . . \$49.99

RF modulator (not shown) lets you use a standard TV set as a computer monitor with (1) or Laser 128 EX (not shown).

3 E 32191—Wt. 2 lbs. . . \$24.99

2 \$13 monthly, no payments 'til January.* Magnavox RGB/composite color monitor. See description on page 614. Order connecting cable below.

3 E 32513C—Wt. 31 lbs. . . \$299.99

Cable connects computers (1), Laser 128 EX (not shown), (4) to (2).

3 E 76650—Wt. 6 oz. . . \$14.99

3 \$11 monthly, no payments 'til January*. Sears SR2000 printer works with every computer we sell. Prints data, word processing at 130 characters per second, near letter quality at 30 CPS. Condensed, enlarged, italics, other type styles. 9-pin print head. Uses continuous or single sheet paper. Cassette ribbon incl. Warranted.** Imported.

3 E 32400C—Wt. 18 lbs. . . \$219.99

Black replacement ribbon for (3).

T 3 E 76735—Wt. 3 oz. . . \$4.99

Cables to connect printer (3) to computers.

For (1) and Laser 128 EX above.

T 3 E 76653—Wt. 9 oz. . . \$16.99

For (4) on p. 617; (1) and 32665 on p. 618.

T 3 E 20905—Wt. 13 oz. . . \$17.99

*See page 305.

**Warranted by Sears or manufacturer. Write for free copy, see page 304

NOTE: Catalog numbers with "T" prefix may take extra time for delivery



\$399.99

\$15 MONTHLY,
NO PAYMENTS 'TIL JANUARY*

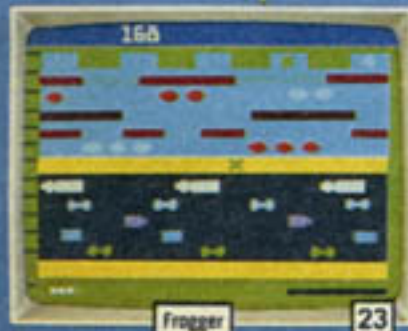

Frogger

23



Donkey Kong

29



Phoenix

24



Vanguard

30

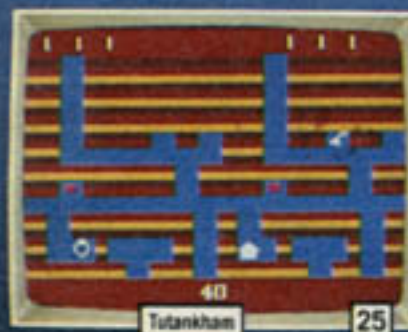

Tutankham

25



Zaxxon

31



Jedi Arena

26



The Empire Strikes Back

32



Dark Cavern

27

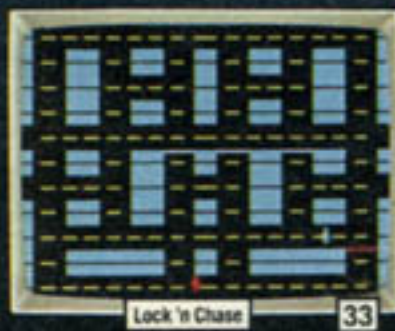

Lock 'n Chase

33



Space Invaders

28



River Raid

34

Ms. Pac-Man

35

Centipede

36

All cartridges are warranted by manufacturer; to write for free warranty copy, see page 323. Shipping weight 4 ounces each.

Cartridge name and description	Catalog Number	Price
(1) RealSports Baseball™ by Atari. Choose pitch, hit and field position. Player-to-player ball control. 4 games, 1 or 2 players	49 C 75130	\$29.99
(2) MegaMania™ by Activision. It's a garbage barrage. Obliterate flying trash. 1 player	49 C 75067	27.99
(3) Raiders of the Lost Ark™ by Atari. Find ark before lightning strikes. 1 player	49 C 75175	27.99
(4) Demon Attack™ by Imagic. Demons split into two when hit. 1 player	49 C 75350	27.99
(5) Galaxian™ by Atari. A fleet of aliens swoop down in formation to attack you. 1 player	49 C 75170	29.99
(6) RealSports Football™ by Atari. 5-player teams tackle it out on a scrolling 100-yard field. 2 skill levels, 1 or 2 players	49 C 75133	29.99
(7) E.T.™ by Atari. Help him phone home. 1 player ..	49 C 75176	17.49
(8) No Escape™ by Imagic. Hit the ceiling to drop a brick on the quickly multiplying nasties. 1 player	49 C 75358	27.99
(9) Atlantis™ by Imagic. Defend the fabled isle from waves of flying foes. 1 player	49 C 75354	27.99
(10) Fathom™ by Imagic. As a seagull, scope shore for Neptune's Trident. Then as a dolphin, dive to free mermaid. 1 player	49 C 75360	27.99
(11) Keystone Kapers™ by Activision. Use escalators and elevators to catch the elusive burglar. 1 player ..	49 C 75071	27.99
(12) DragonFire™ by Imagic. Avoid fireballs as you run across the moat. Once inside dragon's castle, steal his treasure if you dare. 1 or 2 players	49 C 75357	27.99
(13) Spider Fighter™ by Activision. Use your bug blaster to protect your garden from swarms of spiders. 1 or 2 players	49 C 75069	27.99
(14) Enduro™ by Activision. Test your endurance and skill. Drive day and night thru fog and rain. 1 player ..	49 C 75074	27.99
(15) KaBoom!™ by Activision. Catch bombs in buckets. They come faster and more numerous. 1 player ..	49 C 75059	19.99
(16) Smurf™ by Coleco. Help your cartoon favorite jump over obstacles. 1 player	49 C 75551	29.99
(17) Chopper Command™ by Activision. Attack convoy without being shot down. 1 player	49 C 75064	27.99
(18) Pitfall™ by Activision. From jungles to sandy deserts, swing over deadly pits to stay alive. 1 player ..	49 C 75066	27.99
(19) Jungle Hunt™ by Atari. Survive jungle perils to save sweetheart from savage soup pot. 1 player	49 C 75171	27.99
(20) Oink™ by Activision. Huff and puff and blow the pigs' brick wall down. 1 or 2 player	49 C 75072	27.99
(21) Freeway™ by Activision. How does this chicken cross the road? Thru rush-hour traffic. 1 or 2 players ..	49 C 75058	19.99
(22) Strawberry Shortcake™ Musical Match-Ups by Parker Bros. Mix or match parts of characters to create whimsical animation and music. 1 player	49 C 75512	29.99
(23) Frogger™ by Parker Bros. Guide your frantic frog thru traffic and across raging river. 1 or 2 players	49 C 75502	29.99
(24) Phoenix™ by Atari. Blast your way thru relentless waves of oscillating space monsters to destroy their nest. 1 player	49 C 75178	29.99
(25) Tutankham™ by Parker Bros. Snakes, griffins and beetles guard Tut's Treasure. 1 player	49 C 75510	32.99
(26) Star Wars™ Jedi Arena™ by Parker Bros. Train with your LIGHTSABER to become a Jedi Master. 1 player	49 C 75519	29.99
(27) Dark Cavern™ by Mattel Electronics. You're trapped in a maze, chased by evil robots, try to escape. 1 player	49 C 75657	7.99
(28) Space Invaders™ by Atari. Destroy invaders marching down on your lone ship. 1 player	49 C 75153	32.99
(29) Donkey Kong™ by Coleco. Jump barrels, climb ladders—rescue your sweetie from the clutches of Donkey Kong. 1 or 2 players	49 C 75550	29.99
(30) Vanguard™ by Atari. Pilot your ship thru endless tunnel firing at enemy from 4 directions. 1 player	49 C 75177	29.99
(31) Zaxxon™ by Coleco. Fast-paced, 3-D space battle where you attack enemy installations and avoid their defenses to face the deadly Zaxxon robot. 1 player	49 C 75553	29.99
(32) Star Wars™ The Empire Strikes Back™ by Parker Bros. May the Force be with you. 1 player	49 C 75504	29.99
(33) Lock'n Chase™ by Mattel Electronics. Get the bucks but shake those coppers off your tail. 1 player ..	49 C 75655	19.99
(34) River Raid™ by Activision. Destroy enemy bridges and fuel dumps. 1 player	49 C 75068	27.99
(35) Ms. Pac-Man™ by Atari. Guide Ms. Pac-Man thru 2 different mazes. 1 player	49 C 75179	29.99
(36) Centipede™ by Atari. Hit the creepy-crawly and it divides ... each section coming after you. 1 player ..	49 C 75169	34.99



CUT \$40

Our best 25-in. console TV with multi-function remote control

819⁸⁸

• Chairside remote control has Memory, Programmable Scan, Random Access, Mute, Volume Up/Down and Power On/Off



A



Swivel base lets you adjust angle for best viewing.



B



CUT \$21

25-in. swivel console TV with remote control scan function

688⁸⁸



C

CUT \$40

Deluxe 25-in. console TVs with keyboard tuning

649⁸⁸

629⁸⁸



D



Dig Dug



Centipede



Ms. Pac Man



Pole Position



Temple of Apshai

Commodore 64, VIC 20 and ADAM computer software for home entertainment, education and personal business

Commodore 64 entertainment software programs

Title**	Format	Description	Catalog number	Ship. wt.	Price each
Commodore 64 Entertainment Programs					
Centipede	Cartridge	Blast the centipede and his equally creepy companions.	62G40041	9 oz.	42.99
Dig Dug	Cartridge	Burrow underground to escape fire-breathing dragons.	62G40042	9 oz.	42.99
Donkey Kong	Cartridge	Four different screens! Help Mario save his girl.	62G40043	9 oz.	42.99
Joust	Cartridge	Duel the bird-riding gladiators . . . just like the arcade!	62G40044	9 oz.	42.99
Ms. Pac Man	Cartridge	Guide the First Lady of the arcades through multiple mazes.	62G40045	9 oz.	42.99
Pole Position	Cartridge	The ultra-realistic graphics and sounds of the Grand Prix.	62G40046	9 oz.	42.99
Star Wars Arcade Game	Cartridge	Penetrate your opponent's defenses. Become a Jedi Master.	62G40047	9 oz.	42.99
Gyruss	Cartridge	From Neptune to the safe haven of Earth conquering planets.	62G40048	9 oz.	42.99
Miner 2049'er	Cartridge	Control Bounty Bob in his quest to capture Yukon Yokan.	62G40049	9 oz.	32.99
Pitstop	Cartridge	The only road race game where winning is in the pits.	62G1520	9 oz.	32.99
Temple of Apshai	Disk	Fantasy role-playing game in the Dungeon and Dragons tradition.	62G1534	9 oz.	32.99
Temple of Apshai	Cassette	Fantasy role-playing game in the Dungeon and Dragons tradition.	62G1526	9 oz.	32.99
B.C. Quest for Tires	Cartridge	Travel through the world of cartoon "B.C."	62G40050	9 oz.	32.99
Zaxxon	Disk	Fast paced 3-D game where you destroy enemy installations.	62G40051	9 oz.	32.99
Zaxxon	Cassette	Fast paced 3-D game where you destroy enemy installations.	62G40052	9 oz.	32.99
Blue Max	Disk	Control a World War I biplane in battle on a 3-D screen.	62G1529	9 oz.	32.99
Blue Max	Cassette	Control a World War I biplane in battle on a 3-D screen.	62G40053	9 oz.	32.99
Dr. J and Larry Bird	Disk	One on One. Basketball that actually feels real.	62G40054	9 oz.	32.99
Congo Bongo	Cartridge	Dodge the many obstacles to capture Congo Bongo. In 3-D.	62G40055	9 oz.	32.99
Star Trek	Cartridge	The Enterprise battles the deadly Klingons.	62G1524	9 oz.	32.99
Choplifter	Cartridge	Guide your craft to the rescue through the enemy's defense.	62G1522	9 oz.	32.99
Lode Runner	Disk	150 games in problem solving and quick thinking.	62G1533	9 oz.	29.99
Enchanter	Disk	First of a spellbinding series of the Zork tradition.	62G40056	9 oz.	44.99
Buck Rogers	Cartridge	Space action adventure! You're the pilot, navigator and gunner.	62G40057	9 oz.	32.99
Gridrunner	Cartridge	Control your battleship through 20 levels of arcade action.	62G1521	9 oz.	24.99
International Soccer	Cartridge	Realistic player and ball movements are almost real.	62G40059	9 oz.	32.99



Miner 2049'er



Enchanter



Gyruss



Dr. J and Larry Bird

Commodore VIC 20 software programs

Title**	Format	Description	Catalog number	Ship. wt.	Price each
Commodore VIC 20 Entertainment Programs					
Choplifter	Cartridge	Guide your craft to the rescue through the enemy's defense.	62G40082	9 oz.	24.99
Star Wars Arcade Game	Cartridge	Penetrate your opponent's defense. Become a Jedi Master.	62G40085	9 oz.	39.99
Miner 2049'er	Cartridge	Control Bounty Bob in his quest to capture Yukon Yokan.	62G40083	9 oz.	24.99
Q-bert	Cartridge	Bounce from cube to cube avoiding loony characters.	62G40084	9 oz.	39.99
Gyruss	Cartridge	From Neptune to the safe haven of Earth conquering planets.	62G40086	9 oz.	39.99
Commodore VIC 20 Educational Programs					
Hangman/Hangmath	Cassette	Challenges and improves your spelling and math skills.	62G40087	9 oz.	9.99
Math Hurdler/Monster Maze	Cassette	Develop and test math skills, memory and reflexes.	62G40088	9 oz.	9.99
Typing Tutor	Cassette	Learning the keyboard is fun. Start with home keys.	62G40089	9 oz.	17.99
Commodore VIC 20 Personal Finance/Productivity Programs					
Household Finance	Cassette	Track, record and report your personal budget.	62G40090	9 oz.	17.99



Zaxxon

Digital Data Packs for ADAM computer

Title**	Format	Description	Catalog number	Ship. wt.	Price each
ADAM Entertainment Programs					
Donkey Kong Jr.	DDP	Jr. climbs and swings to save papa.	62G1553	6 oz.	34.99
ADAM Educational Programs					
Logo	DDP	Simple yet versatile computer language. Ages 5 to adult.	62G1554	6 oz.	69.99
Electronic Flashcards and Sampler	DDP	Construct your own flashcards on screen.	62G1555	6 oz.	34.99
Smart Letters and Forms	DDP	Hundreds of useful forms for personal or business use.	62G1556	6 oz.	49.99



Donkey Kong



Pit Stop

NOTE: Disk software requires disk drive (20142, key B) sold on page 519. Cassette software requires datasette (20102, key F) sold on page 519. Cartridge software does not require storage, but we recommend the use of joysticks or paddles sold on page 519.

See Commodore 64 educational and personal finance/productivity software on page 518.

See the Commodore 64 computer and a wide assortment of Commodore peripherals on page 519.

*Montgomery Ward Credit customers: This purchase may change your monthly payments depending on the highest balance on your account. Does not apply to AZ, NM and OR residents. See page 497.

OMNI™ ENTERTAINMENT SYSTEM

You're the contestant as electronic Omni hosts game shows, contests, sports quizzes and party games!

119⁸⁸
Until Dec. 1 only

FEATURES: Controlled by special tape cartridges, Omni actually asks 1 to 4 players to answer trivia questions, name tunes and spell words. Answers are entered on a keyboard, while Omni announces winners and solutions and keeps the score on a digital display panel. Includes tape of mixed game categories. Other cartridges sold below. UL listed. Plug-in adaptor incl. AGES: 10 and up.

48 TF 14355—Ship. wt. 8 lbs. . . until Dec. 1, 119.88
48 T 14355 after Dec. 1, 124.99

OMNI CARTRIDGES . . . pop right into Omni console above. State code number. Ship. wt. 8 oz.

01 Password Plus,™ 02 Music Quiz, 03 Sesame St.,™ 04 Movie Trivia, 05 Baseball Quiz, 06 Sports Quiz.

48 TF 14356 until Dec. 1, 10.99
48 T 14356 after Dec. 1, 11.99

01 Jeopardy,™ 02 Words, Words, Words,™ 03 For the Fun of It,™ 04 Re-Action,™ 05 TV Trivia, 06 Football Quiz.

48 TF 14357 until Dec. 1, 10.99
48 T 14357 after Dec. 1, 11.99

© 1981 Children's Television Workshop
™ The Password Co.
™ Califon, Inc.



One-on-one or family fun

A Monkey Business Watch/Game.

FEATURES: Multiple LCD quartz watch functions including time, alarm, stop watch and date with entertaining game theme. Monkey throws coconuts from tree as player moves native to catch the fruit in the basket. Monkey laughs and kicks legs when native misses. Speed at which coconuts are dropped increases gradually to raise level of difficulty. Number of coconuts caught prints out in score area. AGES: 8 and up.

48 T 1473B—Ship. wt. 9 oz. 29.99

B Merlin's™ computer brain boggles your mind!

FEATURES: Challenges you to 6 different games of memory, logic, chance and skill; everything from Tic-Tac-Toe to Blackjack 13. Computer memory counters your moves with strategic maneuvers and communicates with electronic sounds. Uses 6 "AA" batteries.* AGES: 7 and up.

48 T 14057—Ship. wt. 10 oz. 28.77

C Split Second™—a race against time to win!

FEATURES: An electronic hand-held arcade of 5 action games. Try Mad Maze, Space Attack, Auto Cross, Stomp or Speedball—fast, action-filled games. Electronic sounds, scoring and LED lights. 1 or more players. Uses 6 "AA" batteries.* AGES: 7 and up.

48 T 14548—Ship. wt. 1 lb. 6 oz. 39.74

D Super Simon™ . . . over 20 ways to play.

FEATURES: Let Super Simon push your memory to its limits. Repeat ever-increasing color and sound sequences that change with every turn. Or try to follow Super Simon at the same time he spews out his colors and sounds! Uses one 9-volt and 2 "D" batteries.* AGES: 7 and up.

48 T 14671—Ship. wt. 3 lbs. 6 oz. 37.77

SIMON (not shown)—repeat his sequences of colored lights and sounds to win!

FEATURES: Can you repeat exactly Simon's randomly generated sequences? If you slip, Simon will electronically "raze" you! 3 different games. Uses one 9-volt and 2 "D" batteries.* AGES: 7 and up.

48 T 14669 X—Ship. wt. 2 lbs. 8 oz. 27.99

*Batteries not included; order on pg. 380.



- It's a game and it's a watch!
- Complete with five functions



A Christmas convenience—charge it 3 ways!

New at Sears!



**Palm-size Mini-Arcades . . .
action you can hold on to!**

(9 and 10) Fun you simply can't put down . . . plays like your favorite arcades. Sleek plastic housing, only 4 1/4 x 2 1/2 in. Joystick-like controls. One or two player action and scoring. Automatic shut-off. Batteries included. Imported.
For ages 7 years and up.

(9) Eat the energizing dots in the Monster Maze before the monsters eat you. While energized, capture the monsters.
49 C 65138—Shpg. wt. 5 oz. \$24.99

(10) Defend your base against Space Invaders. Move right, move left, fire and fire again!
49 C 65136—Shpg. wt. 5 oz. \$24.99

Quartz Clock and Space Fight game all in one



As digital clock, it displays hours, minutes in 2 time zones, month and date. 12 or 24-hour clock with melody alarm. As game, you fight aliens on 2 skill levels. Plastic, 3 3/4 x 2 1/2-in. housing. Imported. Batteries included. Warranted by Tiger, see page 323.

For ages 7 years and up.
49 C 65133—Shpg. wt. 2 oz. \$19.99

New at Sears!

Hand-held games that do more than give you a giggle

(11) All the basic calculator functions, including a Space Invaders game. Add, subtract, divide, multiply your scores. What's your percentage of wins? Play Space Invaders on 8 skill levels. Automatic shut-off. Plastic, 5 1/4 x 2 1/2-inch housing. Batteries included.

For ages 7 years and up.
49 C 65142—Wt. 5 oz. . . . \$29.99

(12 thru 15) Games that are always right on time. As digital clocks, they're accurate to 1/10 of a second. Displays hour, minute in 2 time zones, month and date. Melody alarm can be set in either zone. Even a stopwatch feature. Play each game on 2 skill levels. Plastic housing. Batteries included.

For ages 7 years and up.
(12) Escape the watchful guards—a real test of reflexes. 3 3/4 x 2 1/4 in.
49 C 65362—Wt. 5 oz. . . . \$19.99

(13) It's a Diamond Hunt. In 3 different situations, played on 3 different screens. Flip open the top panel and struggle with hungry animals, evil spells and seemingly unsurpassable obstacles. Plastic, 4 1/4 x 3 1/2-in. housing.
49 C 65368—Wt. 4 oz. . . . \$24.99

(14) Hippo has nasty cavities developing. Clean his teeth before they fall out. 2 1/4 x 2 1/4 inches.
49 C 65366—Wt. 2 oz. . . . \$14.99

(15) Tennis Menace . . . return your instructor's serves or else. Measures 2 1/4 x 2 1/4 inches.
49 C 65364—Wt. 2 oz. . . . \$14.99

DieHard Alkaline Batteries

Size	Pkg of	Catalog Number	Wt. oz.	Price, per pkg
"AA"	2	49 C 30909	2	\$1.99
"AAA"	2	49 C 30919	1	1.89
"C"	2	49 C 30929	5	2.39
"D"	2	49 C 30939	10	2.39
9-volt	1	49 C 30949	2	2.39



New at Sears!



Turnin' Turbo Dashboard shifts from 1st to 4th in seconds flat!

Digital windshield shows 2 lane highway with landscape swooshing by . . . avoid obstacles, race a tricky computer-controlled opponent. Dash includes speedometer, fuel gauge, and mileage indicator. Requires 4 "D" batteries, not included, sold above. Imported.

For ages 4 years and up.
49 C 65310—Shipping weight 4 pounds \$24.99

New at Sears!

(16 thru 18) Set your sights on a 3-D world of exciting game action

Conquer new worlds, new game experiences. Focus in on unique depths and dimensions, with a different built-in game in each pair of binoculars. Your controls are on top, within easy fingertip reach. Multiple skill levels. 1 player. Plastic. Requires 3 "AA" batteries, not included, sold above.
For ages 6 years and up.

(16) It's a dogfight in Sky Attack. New challenges keep coming at you from out of the blue.
49 C 65306—Wt. 13 oz. . . . \$29.99

(17) Drive your Thundering Turbo down a challenging rapeway. Dodge and pass jams then let 'er really rip on the straightaways!
49 C 65302—Wt. 13 oz. . . . \$29.99

(18) Somewhere in outer space, you defend the Planet Zeon. Maneuver thru the heavens, firing at enemy craft.
49 C 65304—Wt. 13 oz. . . . \$29.99



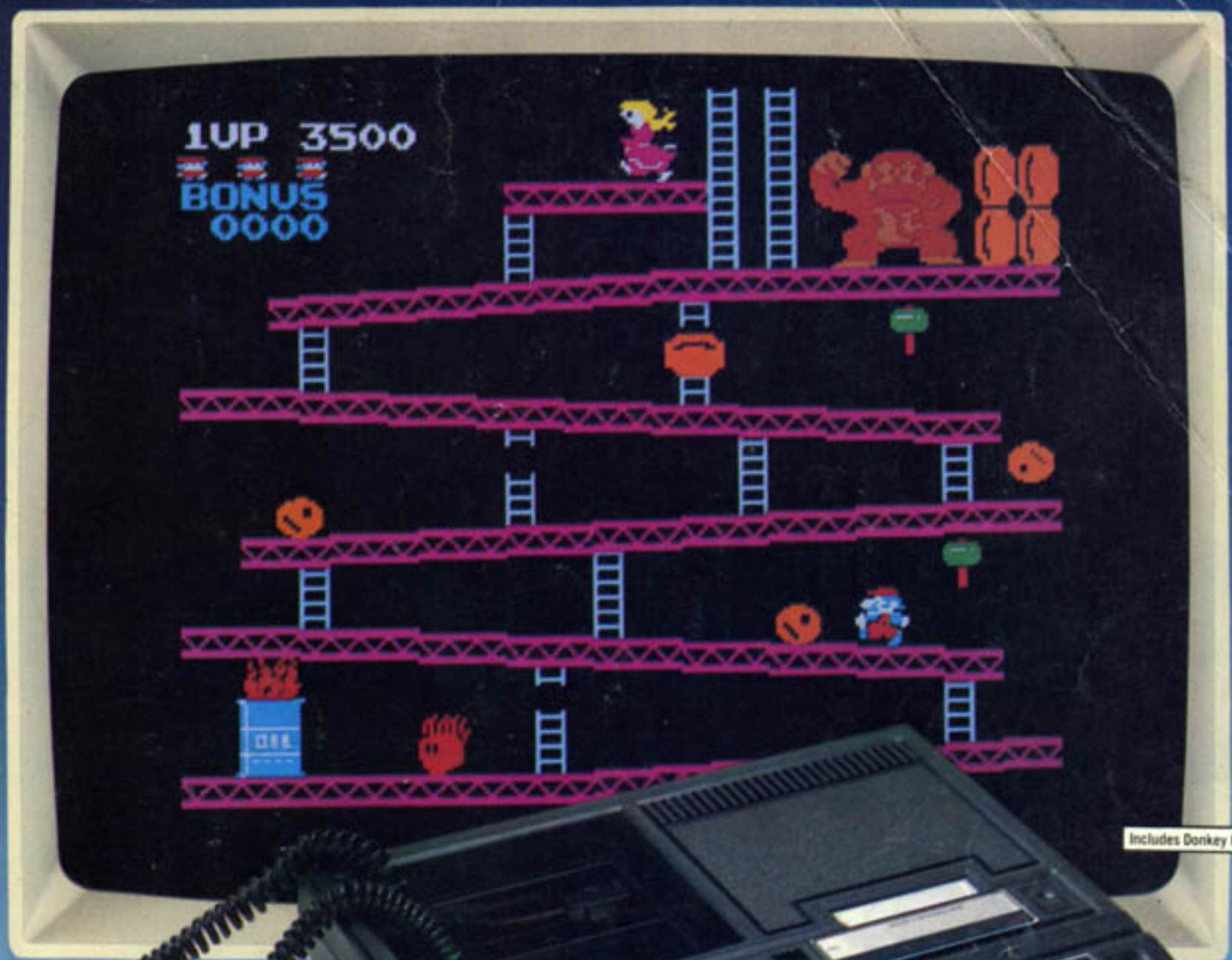

Includes Donkey Kong™



Console
Cut \$40

Play any Atari 2600 cartridge
with Compatibility Module



New! Destructor 5



Football 7



Rocky 8



Includes Turbo

Driving Module lets you
race a high-performance
driving machine



Includes Baseball 6

New at Sears!
Hand-grip Controllers



ALL 611

SOUTH



Pocket sized

Plug-in AC adapter

In the car

On the job site

In the study

Rapidman 800 does a lot for a little price—any way you figure it!

59.95 cash or 6.00 monthly*

Rapidman 800: the Canadian-made electronic calculator that is engineered for businessmen, students, housewives—and is exceptionally low priced. Small enough to fit into your pocket (3 1/8 x 5 1/8 x 7/8"), light enough to carry around (just 7 oz).

No moving parts: advanced L.S.I. (large scale integration) electronic circuitry ensures instant and efficient calculations. Durable plastic casing. Single 9-volt battery (included) gives many weeks of use. AC adapter (sold below) lets you operate on household current—prolongs battery life.

Four-function performance: Rapidman 800 adds, subtracts, multiplies, divides; shows a true credit balance and has overflow indicator. Gives solutions up to 999,999.99 with a bright, magnified display. Fixed, two-place decimal in eight digit display. Feature for feature you'll find the Rapidman 800 is first rate.

- 8-R 7252—Beige casing 59.95
- 8-R 7168—Black casing 59.95
- AC adapter:** saves battery life.
- 8-R 7167—Each 4.95
- Carry case:** black vinyl, foam padded.
- 8-R 7169—Each 1.98

Commodore U.S. 1—big machine capabilities in a mini-desktop model

79.95 cash or 7.00 monthly*

Inexpensive, big-performance electronic calculator has the features of the big machines, less their bulk.

Complete four function performance. Adds, subtracts, multiplies and divides. **True credit balance.** All negative calculations indicated clearly by minus sign in display panel. Big, easy-to-read display with eight digit capacity. Constant function key allows number to be entered and retained as a constant for series multiplication, addition, subtraction or division. **Floating decimal point** gives true answer every time. **No moving parts.** Operates silently, easily and at light-

ning speed, L.S.I. (large scale integration) electronic circuitry. 60-cycle-115 volt operation. Attached 6' cord, 9 x 5 1/8 x 2 1/4". Weight 3 lb.
8-R 7251—Each 79.95

Eaton's Specific Warranty
If calculators prove faulty under normal usage, Eaton's will pay all parts and labour costs for one full year from date of purchase. Warranty limited to original purchaser.

A GREAT GIFT VALUE

SAVE \$70 Only Till December 27, 1980
on Smith Corona Single Element Electric Typewriter

- Interchangeable typing ball lets you change type-styles in seconds
- 12-in. carriage returns with the press of a button ready for the next line of type
- Cassette-ribbon for quick, easy ribbon-changing

A 45-KEY, 90-CHARACTER KEYBOARD. 1 repeat-action key (underscore-and-x) and automatic space bar. Power backspace key for neat corrections. Full tab. Half-space key. Paper support arms. High impact plastic pica-style typing element and cassette ribbon included. For actual size and styles of type, see p. 756 in our big Fall '80 Catalog. Rugged plastic body with tan/brown finish. Molded-plastic carrying case. 115V, AC. UL listed. Warranted by manufacturer—see page 363. Reduced from our big Fall '80 Catalog, see page 757.

X 641-9949 A—Delivery weight 28 lbs. Reg. 369.95; NOW 299.95

Script-style Typing Element for above.

X 641-9998 A—Delivery weight 0.50 lb 14.50

Elite-style Typing Element for above.

X 641-0021 A—Delivery weight 0.50 lb 14.50

Extra Cartridge Ribbon for above. Black fabric.

X 641-0047 A—Delivery weight 0.40 lb 2.75

JCPenney Full One Year Warranty

Within one year of purchase, we will repair or replace at our option this JCPenney Typewriter if defective in material or workmanship. Parts and labor are included. Just return it to JCPenney. For balance of this warranty, see page 363.

Limited Additional 4-Year Parts Warranty

After the first year from date of purchase we will for the following four years, provide replacement parts, without charge, for this JCPenney Typewriter if defective in material or workmanship. Labor of installation is not included. Just return it to JCPenney. Rubber Parts and Electric Motors are not covered by this warranty, see page 363.

SAVE \$10 Only Till December 27, 1980
on Sharp Printer Calculator

B SHARP 1182 * 10-digit, 2-symbol print-out on paper tape, green fluorescent display, or both. Print/non-print selector. Adds, subtracts, multiplies, divides. Performs chain calculations. One-touch percent key. Double zero key saves time when making entries. Constant mode helps speed calculations. Fixed decimal point (3, 2, 0) selector. Plastic housing measures 7 $\frac{1}{4}$ x2x8 $\frac{3}{8}$ in. Operates on 110-120V, AC. UL listed. Includes one roll of paper, ink roller and dust cover. Reduced from our big Fall '80 Catalog, see page 761. Del. wt. 3.50 lbs.

X 641-3835 A Reg. \$79.95; NOW 69.95

SAVE \$2 Only Till December 27, 1980
on Texas Instrument's 30 SP Calculator

E TI-30 SP SLIDE RULE CALCULATOR*. Bright red LED display. 4-key, fully-addressable memory system. Mixed and chain calculation capability. Full floating decimal system. % key. Sign-change key. 8-digits with sign in basic operations; 5-digit mantissa with sign, 2-digit exponent with sign in scientific notation. Raises numbers to power. Performs trigonometric and inverse trigonometric functions. Logarithms. 15 sets of parentheses with 4 pending operations. Solves reciprocal, square root problems. π key. Plastic body. Measures 3 $\frac{1}{4}$ x5 $\frac{3}{4}$ x1 $\frac{1}{2}$ in. Math instruction book included. Uses one disposable 9-volt battery (not incl.), or can be used with UL listed recharger/adaptor kit sold below. Kit includes 2 rechargeable nickel/cadmium batteries and UL listed adapter/recharger that lets you operate on 110-120V, AC. Reduced from our big Fall '80 Catalog, see page 760. Delivery weight 1.60 lbs.

X 641-8727 A Reg. \$16.95; NOW 14.95

X 641-8750 A—Kit for [E]. Del. wt. 1.50 lbs 11.95

SAVE \$7 Only Till December 27, 1980
on Texas Instrument's TI-55 Programmable

F TI-55 KEY PROGRAMMABLE. * Perfect beginning calculator for introduction to programmable calculation. Easy-to-read red LED display. 8 digit mantissa, 2 digit exponent. AOS (Algebraic Operating System) permits left to right problem entry—no need to rearrange equation. 32 fully merged steps. 8 addressable memory registers. 10 labels for versatile program writing technique. 6 conditional branches. 2 loops for repetitive problem solving. Uses 3 rechargeable nickel-cadmium batteries (included) or 110-120V, AC. UL listed, recharger/AC adapter included. Self-teaching manual incl. Plastic body. 3 $\frac{1}{2}$ x5 $\frac{1}{2}$ x1 $\frac{1}{8}$ in. Reduced from our big Fall '80 catalog, see page 759.

X 641-8263 A—Wt. 1.20 lbs. Was \$39.95; NOW 32.95

Our Lowest Priced Calculator
The Sharp EL-211

G CALCULATOR* FEATURES AUTOMATIC POWER OFF FUNCTION—helps conserve batteries when unit is not used for several minutes. 8-digit LCD (liquid crystal display). Basic functions (+, -, x, \div). % and $\sqrt{\quad}$ keys. 3 memory keys. Performs chain, constant, and reciprocal calculations. Uses two AA batteries (included). Measures 2 $\frac{1}{2}$ x3 in. x $\frac{3}{4}$ in. 5 $\frac{1}{4}$ in. Delivery weight 0.75 lb.

X 641-3785 A 9.95



Cartridge ribbon, pica element incl.



NOW ONLY
299⁹⁵

Charge It—
see page 363

After Dec. 27,
Order at Reg. Price



Carrying case included

NOW ONLY
69⁹⁵

Charge It—
see page 363

After Dec. 27,
Order at Reg. Price



SAVE \$10 Only Till
December 27, 1980
on Sharp Hand-held
Printer/display
Calculator

NOW ONLY
49⁹⁵

Charge it—
see page 363

C SHARP 1185 10-DIGIT PRINTER/DISPLAY CALCULATOR*. Easy-to-read bright green display. Full print-out has 10 numerals and two symbols. Adds, subtracts, multiplies, divides. Performs chain calculations. Constant fixed decimal point with add mode. 4-key memory and error indicators. One-touch percent key. Double zero key for faster calculations. Calculator can function without paper. Plastic housing. Measures 3 $\frac{1}{2}$ x2 x 6 $\frac{1}{8}$ in. Operates 110-120V, AC with AC adapter, or uses four rechargeable AA batteries (included). Includes soft case and roll of paper. Reduced from our big Fall '80 Catalog, see page 761. Delivery weight 1.25 lbs.

X 641-3819 A ...Reg. 59.95; NOW 49.95

SAVE \$5 Only Till
December 27, 1980 on
"Checkbook Calculator"

NOW ONLY
24⁹⁵

After Dec. 27, Order at Reg. Price

D CHECKBOOK CALCULATOR* keeps balance for checkbook and 2 other charge accounts, even when calculator is turned off. 8-digit, LCD display. Automatic add-on, discount, net functions. % key. Grand total key. Comes in slim, brushed-metal case. 3 $\frac{1}{2}$ x5 $\frac{1}{2}$ x5 $\frac{1}{8}$ in. wide. 2 silver-oxide batteries (incl.). Reduced from our big Fall '80 Catalog, see page 760. Delivery weight 0.50 lb.

X 641-9501 A ...Reg. 29.95; NOW 24.95

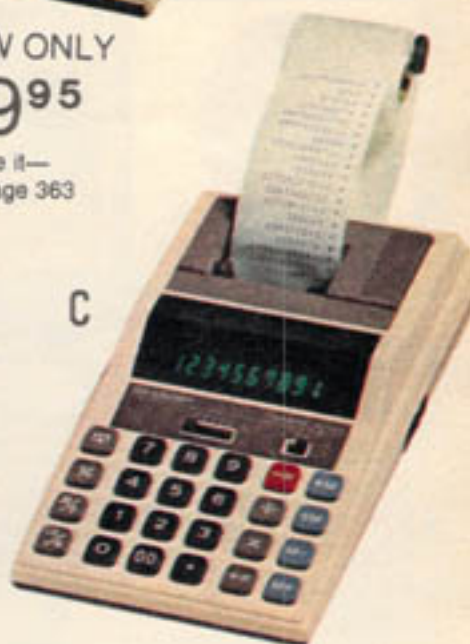



A

Wireless remote control features Picture Search, Still/Pause, Frame Advance, Double Speed plus all VCR functions!

Save \$100 **799.99** No money down
\$40 a month*
RCA VHS Hi-Fi recorder with wireless remote control

Enjoy dynamic Hi-Fi sound along with the added luxury of a multi-function wireless remote control! 6-event/14-day programmable capability lets you program as many as 6 different shows up to 2 weeks in advance. Or, you can record the same shows on a daily or weekly basis for as long as your tape runs. 8-hour capability (depending on tape speed). Hi-Fi stereo system delivers lifelike stereo reproduction with a dynamic range of more than 80 dB. Audio/video in/out jacks permit hook-up to your stereo receiver.

Wireless remote control offers added functions like Picture Search, Still/Pause, Frame Advance, and Double Speed so you can review tapes in a variety of speeds and fashions. 3 heads on VCR allow for all these exciting functions. Remote also controls Play, Record, Stop, Fast-Forward, Rewind and Channel Change. 105-channel electronic soft-touch tuning. One-touch recording. Front-loading. Auto rewind. UL listed. Made in Japan. Mfr.'s Warranty.** Was 899.99, F'84, pg. 683. 63 G 49084 MS—Ship. wt. 25 lbs. now 799.99



Super Gift Offer!
39.99

4 Maxell video tapes plus film buff's Movie Book

Makes a great gift for VCR movie fans. You get 4 Maxell T-120 video cassettes (VHS or Beta) plus a new movie guide entitled "Rating the Movies" that gives a synopsis of your favorite movies. So give someone you love this special video gift combo!
62 G 3307—VHS tapes/Book . only 39.99
62 G 3308—Beta tapes/Book . only 39.99



16.99
TDK 8-hour VHS tape

Enjoy up to 8 hours of recording/playback time on this famous TDK T-160 cassette.

62 G 3323—Ship. wt. 1 lb. . . . each 16.99
*Montgomery Ward Credit customers: This purchase may change your monthly payments depending on the highest balance on your account. Does not apply to AZ, NM and OR residents. See page 497.

572 • ALL ****Write for free copy of Warranty, see page 497.**



B

Save \$60 **469.99** No money down
\$24 a month*
Sanyo Beta VCR with wireless remote control

Sanyo Beta VCR features 3 heads for special functions and a deluxe wireless remote control. 8-event/14-day timer lets you program as many as 8 shows up to 2 weeks in advance. 16-function wireless remote control features Beta Scan (forward and reverse) for high-speed scanning. Still Frame/Frame Advance lets you stop the action, then proceed frame-by-frame. Pause lets you delete unwanted material when recording.

Remote also controls Fast-Forward, Rewind, Play, Stop, Channel Up/Down, TV/VCR, Power On/Off. 12-position electronic soft-touch tuning with 105-channel capability. Lighted channel indicators. Lighted clock/timer. Front-loading. Audio/video in/out jacks for versatile usage. UL listed. From Japan. Manufacturer's Warranty.** Was 529.99 in our '84 Fall Big Book, page 682. 63 G 29084 MS—Ship. wt. 19 lbs. . . . now 469.99



C

SAVE \$130 **369.99** No money down
\$19 a month*
Sony Betamax recorder with Beta Scan

Sony Betamax is loaded with Sony "extras"! 1-event/3-day timer for automatic unattended recording. 5-hour capability (depending on tape speed). 4-function wired remote control features Beta Scan (forward and reverse) for high-speed scanning. Pause, Frame Freeze and Play are also on the remote. Beta Scan/Beta Skip function lets you switch instantly from high-speed forward and reverse (50X) to Beta Search (15X).

Freeze Frame stops playback so you can see every detail. 14-pushbutton express tuning for fingertip ease. Pause control for deleting unwanted material when recording. Auto rewind. Lighted channel indicators. Fluorescent multi-display. Audio/video in/out jacks permit versatility and convenience. UL listed. From Japan. Manufacturer's Warranty.** Was 499.99 in our '84 Fall Big Book, page 682. 63 G 59074 MS—Ship. wt. 23 lbs. . . . now 369.99



F



H

G



I



J

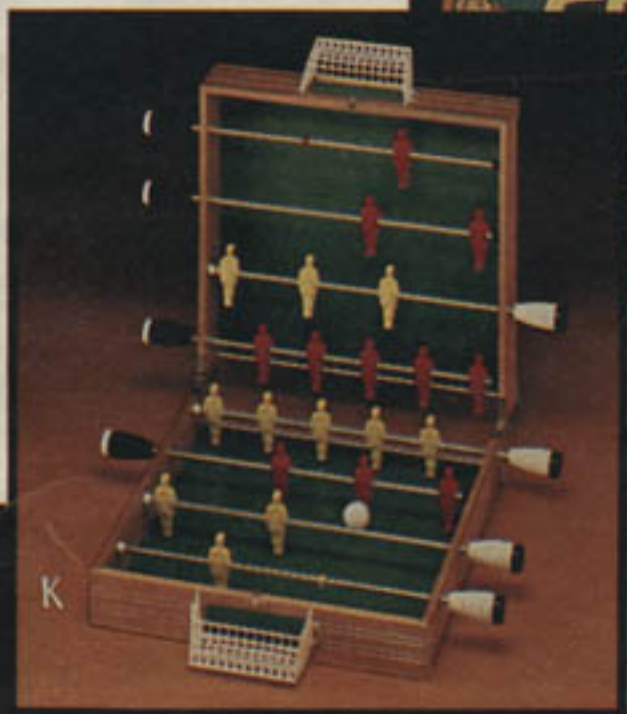

K



N

Actual size!



L



M

Collect all the teams (see inset)

16 Redline Electronic Drag Race
39⁹⁹



Match Me—outwit the light and sound sequences

Tabletop Match Me
24⁹⁷

17



Hand-Held Mini Match Me
19⁷⁹

18



19 Brain Baffler
46⁶⁶



20 Funtronics Red Light/Green Light
15²⁹



21 Funtronics Jacks
15²⁹



22 Plus One
17²⁹

14 Waddington's Wizard. (Shown on opposite page.) Four games demanding skill and memory with 4 levels of difficulty: Match Me, Break-out, Hot Corners, Music Maker—plays back tunes up to 30 notes. 1 to 4 players, ages 7 and up. Plastic. 11x11x4½ in. high. Uses 6 "C" batteries. Also has AC adapter jack (adapter sold on p. 461). Will be \$34.49 on Jan. 24, 1981.

XU 924-4823 A—Del. wt. 2.50 lbs. NOW 32.29

15 Electronic Battleship. (Shown on opposite page.) Warfare on the high seas. Players command 5 ships. Hits are signaled by flashes and explosive sounds. Plastic. 22x11½x5½ in. high. Uses two 9-volt batteries. Warranted by mfr.—see page 363. Two players, ages 8 and up.

XU 925-5316 A—Delivery weight 5.20 lbs. 31.99

16 Redline Electronic Drag Race. Game is in the shape of a dragster steering wheel. You control the throttle and gears as you race. 4 different classes of racing to test your skill. LED readout gives lapsed time and MPH when race ends. Plastic. 6x3½x7 in. high. Uses two 9-volt batteries. Ages 8 years and up. Will be \$42.77 on Jan. 24, 1981.

XU 925-7817 A—Del. wt. 2 lbs. NOW 39.99

17 Match Me. Can you correctly match the increasing sequences of random lights and sounds? 4 game variations at 2 different skill levels, or program your own. Electronic organ—you can compose a tune with up to 32 notes. This tabletop style measures 11x11x2¼ in. high. Uses 4 "C" batteries. 1 to 8 players, ages 7 to adult. Imported from Hong Kong.

XU 924-4864 A—Delivery weight 2 lbs. 24.97

18 Mini Match Me. Pocket-size hand-held electronic game. Same as [17] above, but measures 3¼x6¼x1½ in. high. Uses 4 "AA" batteries.

XU 925-7841 A—Delivery weight 0.70 lb. 19.79

*Batteries not included, sold on page 461.

SAVE THIS CATALOG.
Order anything from pages 375-527
until August 15, 1981

19 Brain Baffler. 8 word and number strategy games with various sound effects. Computer controls action, game play, and scoring for one or two players. 38 character keyboard, 8-digit LED display. Plastic. Measures 6x9½x2½ in. high. Uses one 9-volt battery. For ages 8 to adult.

XU 924-9970 A—Delivery weight 0.40 lb. 46.66

20 & 21 Funtronics Hand-Held Games. Demands skill. Plastic. 4½x7½x2 in. high. Uses one 9-volt battery. 1 or 2 players, ages 5 and up. Will be \$16.88 on January 24, 1981.

[20] Red Light/Green Light. 2 skill levels with 3 speeds at each level.

XU 924-9905 A—Del. wt. 0.40 lb. NOW 15.29

[21] Jacks. 2 skill levels, 5 speeds at each level.

XU 924-9921 A—Del. wt. 0.40 lb. NOW 15.29

22 Plus One. Electronic sensors inside pyramid-shaped playing computer keep track of all moves and eliminate players making a mistake! Plastic. Pyramid 4½ in. high. Play with or without the 11¼ x 13¼ x 4¼ in. board. Uses 4 "AA" batteries. 2 or more players, ages 7 years and up. Will be \$18.49 on Jan. 24, 1981.

XU 924-4963 A—Del. wt. 2.25 lbs. NOW 17.29

23 Stop Thief. Track the invisible criminal! The Crime Scanner gives realistic sounding clues—from creaking doors to sirens and gunshots! Plastic and cardboard. 20x10x1¼ in. high. 2 to 4 players, ages 7 years and up. Uses one 9-volt battery. Warranted by mfr.—see page 363. Will be \$29.79 on Jan. 24, 1981.

XU 923-4279 A—Del. wt. 3.25 lbs. NOW 27.88

24 Electronic Detective. Can create 50,000 different crimes with clues on 24 different suspects. Demands logical reasoning. Lights, sounds, LED readout. Various levels of skill from novice to Master Detective. Plastic. 12x9x2¼ in. high. Uses 6 "AA" batteries. Warranted by manufacturer—see page 363. For 1 to 4 players, ages 10 years and up. Will be \$39.99 on January 24, 1981.

XU 923-3610 A—Del. wt. 2.25 lbs. NOW 37.49



23 Stop Thief
27⁸⁸

Electronic Detective

37⁴⁹
24



JCPenney 451

Fun and Games at the JCPenney Home Arcade



Videocart 2—
Desert Fox

TV not included.
TV sets sold
on page 518.

Fairchild's TV Video Center®

SAVE \$20

NOW ONLY 149⁹⁵ This special price ends Dec. 24

- Hooks up to any TV Set (in color on color TV's)
- Interchangeable cartridges add a whole new spectrum of fascinating games
- Includes two standard built-in games... hockey and tennis.
- Purchase additional cartridges for more games

FAIRCHILD TV VIDEO CENTER. Transform your ordinary TV set into an olympiad of sports fun. Walnut-colored console hooks up easily to any standard TV set in minutes. Attaches to the external VHF antenna leads on your TV. Once the console is attached, there is no need to disconnect it. When it's off, it will not interfere with normal TV viewing. Plug it into any electrical socket. How does it work? The heart of the console is a microprocessor, a small computer with a memory that is programmed with thousands of pieces of information. Instructions are contained in each cartridge and fed into the computer. Now press the hockey button and you're ready to play. Puck can be passed around from forward to goalie and shot at varying angles. Score! Now try the tennis game. When player misses the ball, the other scores a point. Both hockey and tennis are built into the console. But the fun doesn't end here. You can purchase additional video cartridges (order below), plug them into the console, and play even more games! Games are for 1 or 2 players. Great fun! Not available: see page 338. Shipping weight 6 lbs. Reduced from our Fall '77 Catalog—see page 719. After Dec. 24, order at Regular Price of \$169.95

X 917-2032 A—Console with hockey, tennisNOW 149.95

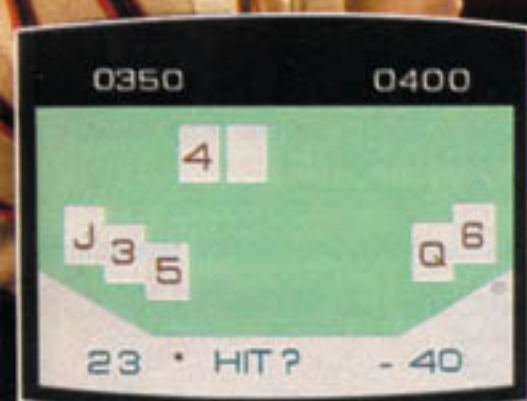

In **BLACKJACK** for two players (Videocart 3), you try to beat the computerized dealer.



In **TIC-TAC-TOE** (Videocart 1), you play the computer. Try to get three marks in a row.

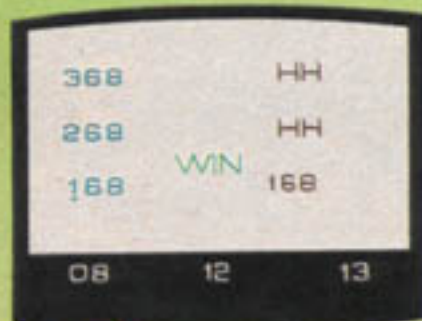

Videocart 8—
Mindreader
(1 player)

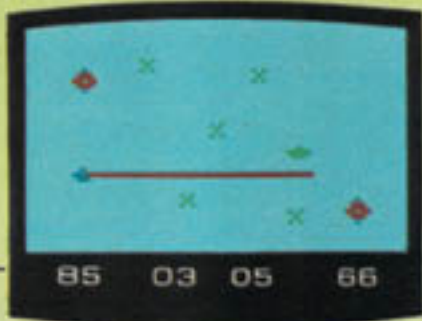

Videocart 5—
Space War



Videocart 4—
Spitfire



Videocart 7—
Multiply, Divide

Order Additional Cartridges for Fairchild Video Center

19⁹⁵ each

VIDEOCART 1. Contains four games—Tic-Tac-Toe, Shooting Gallery, Doodle, Quadra-Doodle. X 917-2040 A—Wt. 0.40 lb. .19.95

VIDEOCART 2. Contains two games—D. Fox, Shooting Gallery. X 917-2057 A—Wt. 0.40 lb. .19.95

VIDEOCART 3. Blackjack. X 917-2065 A—Wt. 0.40 lb. .19.95

VIDEOCART 4. Spitfire. X 917-2073 A—Wt. 0.40 lb. .19.95

VIDEOCART 5. Space War. X 917-2081 A—Wt. 0.40 lb. .19.95

VIDEOCART 6. Baseball. X 917-2644 A—Wt. 0.40 lb. .19.95

VIDEOCART 7. Multiply, Divide. X 917-2396 A—Wt. 0.40 lb. .19.95

VIDEOCART 8. Mindreader, Nim. X 917-2479 A—Wt. 0.40 lb. .19.95



7

Fast-action Pinball excitement

(7) **Snap 'n Spin Football.** Snap-back action lever sends steel ball into action on simulated football field. Try to score the most touchdowns, field goals or extra points.

CONSTRUCTION: Molded plastic base, clear plastic bubble. 16 1/4 x 7 3/4 x 8 in. high. 9 steel balls. Manual ball return.

AGES, ORDERING INFO: 4 to 12 years. 49 C 62071—Shpg. wt. 2 lbs. 8 oz. \$6.49

(8) **Power Pro Electric Pinball Game**

Lift steel ball into launch chute, fire into play. Keep ball scoring with 2 independent flippers. 6 solenoid power bumpers for fast action; 3 scoring flip cups. Digital L.E.D. scoring with memory.

CONSTR: Wood base; sturdy metal legs. 2 steel balls. Enclosed lithographed play surface; tilt mechanism. 34 in. high. 33x18x57 in. high overall.

ELEC INFO: UL listed. 110-120-v., 60-Hz. AC. 23 watts. 6-foot cord. Not for under 10 yrs.

AGES, ORDER INFO: 10 yrs. and up. Warranted by Marx. Write for free copy, see pg. 322. Unassembled. Instr. "N" suffix, page 322.

79 C 62669N—Shpg. wt. 40 lbs. \$126.97

(9) **Disco Pinball Game.** Lift steel ball from beneath playing surface; submarine ball-loading mechanism. Fire into play. Keep ball scoring with 2 independent replay flippers. 2 solenoid power bumpers for fast action, 10 standard bumpers, 4 bonus tracks. When bumper is hit, bell rings, score advances. Push button release for new game.

CONSTR: Molded plastic base on sturdy metal legs. 5 steel balls. 42x21x57 1/4 in. high. Enclosed lithographed play surface.

ELEC INFO: UL listed. 110-120-v., 60-Hz. AC. 15 watts. 6-foot cord.

AGES, ORDER INFO: 8 years and up. Warranted by Wolverine. Write for free copy, see pg. 322. Partly assembled. Instructions included. See "N" suffix note, p. 322.

79 C 62632N—Shpg. wt. 39 lbs. \$96.99

(10) **Cycle Speedway Pinball Game**

Lift steel ball into launch chute, fire into play. Keep ball scoring with 2 independent flippers. 11 bumpers. 2 bonus channels.

CONSTR: Sturdy wood; tubular steel legs. 1 steel ball. Enclosed lithographed play surface. 37x21x50 in. high.

ELEC INFO: UL listed. 110-120-v., 60-Hz. AC. 14 watts. 6-foot cord.

AGES, ORDER INFO: 6 years and up. Partly assembled. Instr. incl. Warranted by Coleco Industries. Write for free copy, see pg. 322.

79 C 62277L—Shpg. wt. 27 lbs. \$66.99

(11) **Sea Battle Electric Pinball Game**

Lift steel ball from under playing surface with submarine loader, fire into play. Keep ball in play with 2 independent flippers. 11 bumpers, 2 bonus score channels. Reset dial.

CONSTR: High-impact plastic case, legs. Enclosed lithographed play surface. 5 steel balls. 29x14x43 inches high. Play surface, 27 inches high.

ELEC INFO: UL listed. 110-120-v., 60-Hertz AC. 11 watts. 6-ft. cord. Not for under 8 yrs.

AGES, ORDER INFO: 8 years and up. Unassembled, instruction included, if mailed, takes 15-lb. rate; see page 322.

79 C 62631L—Shpg. wt. 14 lbs. \$34.99

- Solenoid power
- Electronic digital scoring for 1 or 2 players

- Solenoid power for bounce-back action
- Random flashing lights highlight disco scenes



8

9



- Scores up to 4000
- Bonus scoring up to 2000

10



- Automatic score
- Bonus score
- Submarine load

11

A barrel of Pinball fun in a pocket sized package

(12) Three different games with ingenious mechanisms that make challenging games for one or more players. Incl.: Times up, Shooting Gallery and Obstacle Course.

CONSTRUCTION: Plastic. Each measures 4 3/4 x 2 3/4 x 3/4 inches high.

FOR AGES: 5 and up.

ORDERING INFORMATION:

49 C 62039—Wt. 12 oz. Pkg. \$3.99



12

GAMES



Add action to your game room



Item (1)
Cut \$8

1. The sky's the limit with the NASA "American Adventure" game. This arcade-like game features pro-style ball loading, 10 scoring bumpers and 4 bonus score channels. Score up to 100,000 points on the automatic scoring wheel (manual scoring up to 500,000). Also includes 2 replay flippers plus a ringing bell and flashing light to add to the fun. Steel playing base with high-impact plastic housing has steel legs that fold for convenient storage. 32x17 1/4x50 inches high. Uses AC power. 6-ft. cord. Partly assembled; instructions incl. Was \$87.99 in our 1984 Christmas Book, page 579. For ages 8 years and up. 49 C 62639L—Wt. 20 lbs... Now **\$79.99**

2. Make points with Laser Lords pinball. Bring the futuristic world of space battle into your family room. Features 11 scoring bumpers and automatic scoring dial. Flashing lights and ringing bell add excitement. 2 independent replay flippers. Durable steel playing surface housed in a plastic frame with plastic legs. Partly assembled; instructions included. 28x13x43 in. high. Requires 4 "D" batteries, sold sep. on page 459. For ages 5 yrs. and up. 49 C 62641L—Wt. 13 lbs. 8 oz... **\$39.99**

3. For the sports fan on your list... Power Jet™ Hockey. This exciting game makes a great addition to any family game room. Electric motor/blower forces air through tiny jets on 44x20-inch playing field so puck skims friction-free on a cushion of air. Built-in plastic goals and scorekeepers. 2 plastic pucks and 2 controller hockey sticks. Attractive walnut-grained cabinet with braced steel legs. Recessed wood-grained leg panels. Stands 29 1/4 inches high. Uses AC power. 6-foot cord. Partly assembled; instructions included. For ages 8 years to adult. 49 C 62302L—Shpg. wt. 23 lbs... **\$59.99**

4. Experience real hockey action with tabletop Carrom® Face-Off Hockey. Electric motor/blower provides air current that allows same friction-free puck travel as in real ice hockey. Includes plastic pucks, controllers and goals. Cherry walnut wood-grained frame with plastic playing surface. Uses AC power. 5-foot cord. Unassembled. 45x21x14 inches high. Instructions included. For ages 6 years and up. 49 C 62138L—Shpg. wt. 24 lbs... **\$39.99**

5. Enjoy 2 games in one with the Carrom® shuffleboard game. This wooden tabletop game combines the action and excitement of the outdoor court game with that of the indoor long board game. Both are easy to learn yet offer opportunity for strategy and skill. Includes 8 roller pucks and official rules. 46x13x1 1/2 inches high. For ages 8 years to adult. 49 C 62126L—Shpg. wt. 17 lbs... **\$29.99**

6. Try your skill at Robot Pinball. This tabletop model operates just like traditional floor-model pinball games. Features automatic scoreboard, ringing bell and flashing light for excitement. 19x10x12 inches high. Requires 4 "D" batteries, sold separately on page 459. For ages 5 years and up. 49 C 62435—Wt. 6 lbs... **\$14.99**

7. Get indoor soccer action with deluxe KIK-IT®. Players manipulate offensive kicker figures to work ball through defensive line into the net pocket goal. Free-moving hardwood rods allow 2 to 6 players to match speed and dexterity in kicking or passing ball. Smooth decorated hardwood playing surface. 40x20x3 1/2 inches high. For ages 5 years and up. 49 C 62132L—Shpg. wt. 12 lbs. 8 oz... **\$19.99**

movies or record programs while you're away!

A NEW! 1-day/1-program programmable Video Cassette Recorder will automatically turn on, record and turn off once in a 24-hour period.

OPERATION: Play and record in 2-4-6-hour modes—lets you capture any TV program for repeated viewing. SP/LP/SLP speeds lets you select speeds for recording (2, 4, 6 hours).

FEATURES: Built-in clock/timer allows you to program one selection while you're away from home. Big illuminated time display. Remote Pause control lets you skip unwanted material like commercials. Picture Scan (in 6-hour model lets you see picture in fast-forward or reverse to go to desired segments. Still Frame (in 6-hour model) lets you freeze the action whenever you want. Memory Counter lets you return to a specific point in recording and playback.

CONTROLS: Electronic soft-touch tuning lets you select any channel with the touch of a finger. Feather-like touch controls for functions.

CONSTRUCTION: 100% solid state integrated circuitry. Lighted channel indicators. Jacks for mike and camera. UL listed. One 60-min. tape included. 5 7/8" H x 19 1/2" W x 14 1/4" D.

ACCESSORIES: Order optional camera at right. Order wired multi-function remote control below.

ORDERING INFO: Wards Warranty.*

63 T 10622 AS—Ship. wt. 32 lbs. 989.88

4-FUNCTION WIRED REMOTE CONTROL (not shown). For use with Video Cassette Recorder (A). Functions include: Pause/Still, Scan (fast-forward or reverse), Channel change.

63 T 10634 LS—Ship. wt. 6 oz. 37.95

6-FUNCTION WIRED REMOTE CONTROL (not shown). For use with Video Cassette Recorder (A). Functions include: Play, Record, Stop, Pause/Still, Rewind, Fast-forward, Picture Scan (fast-forward or reverse), Channel change.

63 T 10635 LS—Ship. wt. 7 oz. 67.95

B NEW! 2-week/8-program programmable 4 Video Head Cassette Recorder with wireless remote control and Special Effects.

OPERATION: Can be set to turn on and off and change channels up to 8 times over a 14-day period. Play and record in 2-4-6-hour modes. Lets you capture any program for repeated viewing. SP/LP/SLP speeds lets you select speeds for recording (2, 4, 6 hours).

FEATURES: Full function wireless remote control for arm chair ease (see on opp. pg.). Programmable clock/timer allows you to program 8 selections at once. Big illuminated time display. Picture Scan (in 2-4-6 hour modes) lets you see the picture in fast-forward or reverse to desired place on tape. Still Frame/Frame Advance (in 2 and 6-hr. modes) allows you to freeze action or advance it frame by frame. Memory Counter lets you return to a specific point in record and playback. Double Speed and Slow Motion.

CONTROLS: Electronic soft-touch tuning eliminates unnecessary wear on the tuner. Feather-like touch control for functions.

CONSTRUCTION: 100% solid state integrated circuitry. Lighted channel indicators. Jacks for mike, camera. UL listed. One 60-min. tape included. 6 9/8" H x 19 1/2" W x 14 1/4" D.

ACCESSORIES: Order optional camera at right. **ORDERING INFO:** Wards Warranty.* Do not order till Nov. 1, 1981.

63 T 10624 AS—Ship. wt. 41 lbs. 1389.88

C NEW! Portable Video Cassette Recorder lets you make movies anywhere—even outdoors!

OPERATION: 3-way operation—AC for home use, DC with built-in rechargeable battery, or use car battery (order optional adapter below). You can check your golf swing or tape a Little League game and enjoy playback as soon as you get home! Play and record in 2-4-6 hour modes. SP/LP/SLP speeds lets you select speeds for recording (2, 4, 6 hours).

FEATURES: Digital clock/timer. Pause control lets you skip unwanted material like commercials. Picture Search (in 6-hr. model lets you see the picture in fast-forward or reverse-rapid access to desired place. Still Frame/Frame Advance (in 6-hr. model) lets you freeze the action or advance it frame by frame. Memory Counter lets you return to a specific point in recording or playback.

CONTROLS: Electronic pushbutton tuning. Feather-like controls for functions.

CONSTRUCTION: Consists of tuner and portable deck. 100% solid state integrated circuitry. Lighted channel indicators. Jacks for mike, camera. UL listed. One 60-min. tape included. Deck: 4 1/8" H x 12 1/4" W x 9 3/4" D. Tuner: 4 1/8" H x 10 1/2" W x 9 3/4" D.

ACCESSORIES: Order optional camera at right. Order adapter, car cord, case below.

ORDERING INFO: Wards Warranty.*

63 T 10620 AS—Ship. wt. 31 lbs. 889.88

63 T 10615—AC ADAPTER. Wt. 8 lbs. 8 oz. 147.95

63 T 10631—CAR CORD. Wt. 5 oz. 14.95

63 T 10632—PORTABLE CASE. Wt. 2 lbs. 4 oz. 47.95

62 T 10671—Blank 2 1/8 HR. CASSETTE. Wt. 15 oz. 21.99

*See Wards Warranty in Big Book or write for free copy, see page J22

NEW! VCR color camera 3X 849⁸⁸

Make your own movies in living color!

OPERATION: Plugs into Video Cassette Recorders (A), (B), (C) on opposite page. For VCRs (A), (B) order AC adapter below. Trigger start/stop.

FEATURES: Compact and lightweight! 1.5-in. electronic Viewfinder/Monitor with Instant Replay lets you check-out your footage on the spot! Automatic 3:1 Zoom Lens. Color Temperature Switch and White Balance adjustment. Extendible boom microphone. Stand-by switch saves battery power.

CONSTRUCTION: Includes 8-ft. cable. UL listed.

ORDERING INFO: Wards Warranty.*

63 T 10637 LS—Ship. wt. 7 lbs. 1 oz. 849.88

63 T 10639—AC ADAPTER. Wt. 3 lbs. 9 oz. 57.95

63 T 10640—EXTRA CABLE. 20-ft. Wt. 1 lb. 2 oz. 57.95



CUT \$70 Our best 19-in. remote control TV 519⁸⁸

TUNING: All 105 channels are tuned to their exact frequency—just use the handy remote control for a random look at any channel. Remote also features Memory and Favorite Channel Scan that locks-in your favorite channels for instant recall. Remote also has mute, volume up/down, power.

CONSTRUCTION: VIR "Plus" circuitry automatically monitors and corrects your picture so you see the best possible colors at all times. 100% solid state chassis for long life. Precision Negative Matrix picture tube delivers bright colors. Automatic Light Sensor automatically regulates picture brightness. LED channel display. Cable-ready to accept 105 channels including non-scrambled mid-band and super-band cable TV channels. CATV jack, Audio output jack, 4-in. speaker, VHF and UHF antennas. 19-in. (diag.) screen. UL listed. **CABINET:** Attractive modern woodgrain hi-impact plastic. 17 1/2" H x 25" W x 17 in. D.

ORDERING INFO: Wards Warranty.* Shown with simulated reception. Was 589.95 in our Big Fall Book, page 1030.

63 T 12993 R—Ship. wt. 72 lbs. now 519.88

See more TVs on pages 344-347, 350-351.

O'SULLIVAN TV/VCR/VDP stands

D Hi-boy video center stand holds VCR, Video Disc Player and television. **CONSTRUCTION:** Hand-rubbed woodgrain finish. Smoked glass doors. 45 1/4" H x 28 1/4" W x 17 in. D.

63 T 13936 R—Ship. wt. 95 lbs. 99.88

E Lo-boy VCR stand holds VCR or Video Disc and TV. Base swivels to allow viewing TV at different angles! Storage compartment.

CONSTRUCTION: Hand-rubbed woodgrain finish. 30 1/2" H x 27" W x 14 1/2 in. D.

63 T 13926 R—Ship. wt. 82 lbs. 79.88



D
Hi-boy
99⁸⁸

E
Swivel
Lo-boy
79⁸⁸



ALL WARDS 349



FOR YOUNG PINBALL WIZARDS...

A Invaders Pro-Style Pinball. Perfect family fun for the rec room. 10 scoring bumpers, 4 bonus score channels. Score up to 100,000 points on automatic scoring wheel. 2 replay flippers, ringing bell, flashing lights. Steel playing base, high-impact plastic housing; steel legs fold for storage. AC adapter included, with 6' cord. For 1 or more players. About 32 x 17 1/2 x 50". Easy assembly.
492 562 737 DL—Ages 8 and up. Each 159.99

B Laser Lords Pinball. Scoring bumpers. Automatic scoring dial; flashing lights, ringing bell. 2 independent replay flippers. Steel playing surface housed in plastic frame with plastic legs. For 1 or more. About 28 x 13 x 43". For ages 5 and up. Requires 4 'D' batteries (not included—sold on p. 398).
492 562 500 DL—Easy assembly. Each 99.99

EXCITING TABLE SOCCER

C Super Sport Table Soccer. Two 11 player teams of high impact plastic; 2 molded soccer balls. Metal telescoping player rods with easy grip handles. Tubular steel legs. Abt. 42 3/4 x 20 x 30". For 2 or more players ages 8 and up.
492 562 940 DL—Each 149.99



G-H Talking Football or Baseball. Electronic table-top LCD game. Built-in voice synthesizer with announcer taking player through game. One or more players. English. For ages 6 and up. Requires 4 'AA' batteries (not included—sold on p. 398).

(G) Talking Football.
492 562 301—Each 64.99
(H) Talking Baseball.
492 562 302—Each 64.99



D-F Exciting VCR Games provide hours of thrilling fun. Use with VCR and TV (not included). Board playing surface and pieces included. For 2 or more players.

(D) VCR Hockey Game. Exciting hockey action on a tape of real NHL plays. Never the same game results twice! For ages 10 and up.
English Version.
492 562 222—VHS. Each 59.99
492 562 223—Beta. Each 59.99
French Version. Toronto shipped.
492 562 224 T—VHS. Each ... 59.99
492 562 225 T—Beta. Each ... 59.99

(E) VCR Quarterback Game. Experience the thrill of being quarterback with 400 NFL plays. Incl. film of every NFL team. Ages 10 and up. English only.
492 562 211—VHS. Each 59.99
492 562 221—Beta. Each 59.99
(F) Clue II™. Another exciting and intriguing episode of this classic VCR whodunit. 18 different mystery cases. For ages 13 and up. English only.
492 562 011—VHS. Each 49.99
492 562 012—Beta. Each 49.99



A 46⁹⁵



39⁹⁵

G



B



F

49⁹⁵



C Dixie Cannon Alarm

39⁹⁵



D



E

ELECTRONIC SPORTS GAMES



Remote control pitching unit for (1)

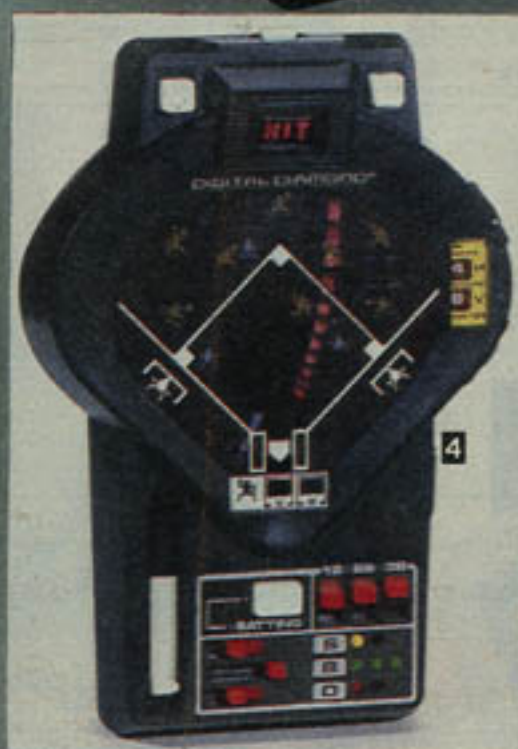

(1) **Electronic Baseball.** You can be the batter, or try your hand as a big league pitcher and show off your fastball. 5 different pitches; if you're playing alone, use "computer" pitcher; or with another player, pitch fastballs, changeups, curves, sliders or knucklers. Remote control pitching unit lets you conceal your pitching strategy. LED readout keeps track of all balls, strikes, outs, base runners and score. You'll see flashing lights and hear a different sound on every play. Watch the players "run" around the diamond on a hit. Once you've hit the ball, computer decides if you'll score. No TV set needed. Includes scoring sheets, instr.

CONSTR: Plastic. Measures 8 $\frac{3}{4}$ x6 $\frac{1}{4}$ x1 $\frac{1}{4}$ in. high.

FOR AGES: 6 years to adult.

ORDER INFO: Uses 3 "AA" batteries, not included; (order packages below). Warranted by Entex Industries; for free copy, see page 322.

49 C 62275—Shipping weight 1 lb. 4 oz. \$28.47

Package of 2 "AA" Alkaline Batteries

49 C 46819—Shipping weight 2 oz. Pkg. \$1.19

Package of 2 "C" Alkaline Batteries

49 C 46839—Shipping weight 5 oz. Pkg. \$1.39

(2 and 3) **Electronic Hockey and Soccer.** Hand-held electronic games let you play against another player or computer on the ice or playing field. You control the offense by moving puck or ball down field, setting up shot, then shooting. Your opponent or the computer attempts to block or intercept puck or ball on defense. Blips of light represent each player and blinking light blip the puck or ball. Both games feature special electronic sound effects, LED position indicators, digital scoring, automatic timing, 4 direction keys and shoot button.

CONSTRUCTION: Plastic, each 8 $\frac{3}{4}$ x5 $\frac{1}{4}$ x1 $\frac{1}{4}$ inches high.

FOR AGES: 6 years to adult.

ORDERING INFORMATION: Each uses 3 "AA" batteries, not included (order packages at left). Warranted by Entex Industries, Inc.; for free copy, see page 322.

(2) **Electronic Hockey Game**

49 C 65777—Wt. 1 lb. 7 oz. \$29.97

(3) **Electronic Soccer Game**

49 C 65779—Wt. 1 lb. 7 oz. \$29.97

(4) **Digital Diamond.** A push-button 2-player baseball game. Pitcher can throw fastball or curve, batter can hit or miss. If it's a hit, digital light goes into field. The fielder-pitcher then pushes button to see if it's a single, double, triple, out or home run! Scoreboard registers score, men on base, balls, strikes, outs. No TV set needed.

CONSTR: Plastic, 8 $\frac{3}{4}$ x6x2 $\frac{1}{2}$ inches high.

FOR AGES: 6 years to adult.

ORDERING INFO: Uses 2 "AA" batteries, not included (order package at left).

LAST DATE TO ORDER THIS ITEM IS JAN. 31, 1980

49 C 65043—Shipping weight 1 lb. \$9.97

(5) **Digital Derby Auto Raceway.** How many laps can you race before time runs out? Steer, shift, race against other drivers but if you crash, the alarm flashes and costs you laps.

CONSTR: Plastic, 8 $\frac{3}{4}$ x6x2 $\frac{1}{2}$ in. Lap counter, reset button, automatic timer. For 1 player.

FOR AGES: 6 years and up.

ORDERING INFO: Uses 2 "C" batteries, not included (order package at left).

49 C 62006—Wt. 1 lb. 3 oz. \$14.27



1 **Only at Sears!** Take a trek thru the wild with this action-packed Jungle Fighter pinball. It's like being in a real arcade. Features include professional-style ball loading, 12 scoring bumpers and 4 bonus score channels. Score up to 100,000 points on the automatic scoring wheel (manual scoring up to 500,000). Ringing bell and flashing light add to the excitement. 2 independent replay flippers. Steel playing base has high-impact plastic housing and steel legs. 38x19x53 in. high. Uses AC power. 6-ft. cord. Partially assembled. Not recommended for ages under 8 years. 49 N 62608C—Shipping weight 34 pounds. Thru December 15th . . . \$119.99
After December 15th . . . \$134.99

2 The sky's the limit with the NASA "American Adventure" game. This arcade-like game features pro-style ball loading, 10 scoring bumpers and 4 bonus score channels. Score up to 100,000 points on the automatic scoring wheel. Also includes 2 replay flippers plus a ringing bell and flashing light to add to the fun. Steel playing base with high-impact plastic housing has steel legs that fold for convenient storage. 32x17 1/4x50 inches high. 6-ft. cord. Partly assembled. Not recommended for ages under 8 years. 49 N 62639L—Shpg. wt. 20 lbs. . . \$79.99

3 Make points with Laser Lords pinball. Bring the futuristic world of space battle into your family room. Features 11 scoring bumpers and automatic scoring dial. Flashing lights and ringing bell add excitement. 2 independent replay flippers. Durable steel playing surface housed in a plastic frame with plastic legs. Partly assembled; instructions included. 28x13x43 in. high. Requires 4 "D" batteries, sold on page 404. For ages 5 yrs. and up. 49 N 62641L—Shpg. wt. 13 lbs. 8 oz. . . \$49.99

4 Try your skill at Robot Pinball. This tabletop model operates just like traditional floor-model pinball games. Features automatic scoreboard, ringing bell and flashing light for excitement. 19x10x12 inches high. Requires 4 "D" batteries, sold separately on page 404. For ages 5 years and up. 49 N 62435—Shpg. wt. 6 lbs. . . \$14.99

Save \$15
thru Dec. 15th

SPACEMAKER TV

MOUNTS EASILY UNDER ANY KITCHEN CABINET, LEAVING COUNTERSPACE CLUTTER-FREE!



Ideal for the workshop, rec room, bedroom, kitchen, office or den



Ready to go anywhere—patio, beach, boat, car, camper, sports events



Adjustable swivel bracket lets you watch TV from anywhere in the room!

- 5½" (14 cm) diagonal color TV
- Receives up to 12 VHF channels, 54 UHF channels
- Enjoy clear, pure AM/FM radio sound from the 4" dynamic speaker
- Removable sun-screen for viewing in bright light

Enjoy this entertaining "kitchen companion" at home or on the road! Has detachable VHF bi-pole and clip-on UHF bow-tie antennas. LED tuning pinpoints, fine-tunes channels. Plastic case, carry handle, tilt stand. 10 x 6 x 11" (25 x 15 x 27 cm) without bracket. Weighs 10 lb. 578 514 897 DL—Each . . . 399.99

Three-Way Power Capability

- Detachable AC cord
- DC adapter
- Built-in rechargeable circuit for battery (optional)

399⁹⁹
Each

TIRED OF MISSING IMPORTANT CALLS?
THE ANSWER IS ON THE NEXT PAGE!
ORDER NOW—OFFER ENDS DEC. 12



SAVE \$400

When You Buy Either One of Our Portable VCR/Tuners in Combination with Camera [B]

Portable VCR/14-Day Programmable Tuner and Camera Combination. If purchased separately would cost \$2178.00. Delivery Class C—see page 364.

X 855-2598 A—Delivery weight 52 lbs. Combination 1778.00

Portable VCR/24-Hour Tuner and Camera Combination. If purchased separately would cost \$2078.00. Delivery Class C—see page 364.

X 855-2606 A—Delivery weight 52 lbs. Combination 1678.00

Give the gift that opens up an exciting new world of entertainment for the whole family. Capture the sights and sounds of the holidays, sports events, or any of those once-in-a-lifetime family events at home or away.

In addition, our video recording system saves you time and money. Unlike regular movie film, there's no processing to wait for and you can reuse the tapes over and over again. Also, there's no projector or screen to set up.

To record live action, connect a video camera to our portable recorder.

To record TV Shows, select one of our versatile VCR/Tuners. Choose either the 14-day programmable or the 24-hour model. Then, hook it up to any black and white or color TV set and you have all the features of our regular home recorders plus portability. It's the ultimate gift.

- Watch your favorite TV Shows at your convenience—never miss a TV program again—tape one while you watch another one—record shows even when you're away from home or while you're sleeping
- Edit out unwanted sections with remote pause control
- Play pre-recorded video cassettes of movies, sports events, special shows, and instructional programs
- Convert your home movies and slides to video cassettes—do it yourself—see below right
- Backed by JCPenney warranties—see below right

A Portable VHS Video Cassette Recorder with 14-day Programmable Tuner Pack. Built-in electronic timer lets you program 8 different shows up to 2 weeks in advance. Records up to 6 hours on a single cassette. Full feature unit includes tape counter with memory switch; direct-drive system for synchronized steady pictures; remote pause control with 20-ft. cable; pushbutton touch controls; 2-hr. blank cassette (order extra cassettes below); microphone jack. VCR weighs approx. 12.3 lbs. Handy carry case sold separately (see at right). Triple-powered—operates on rechargeable battery (not incl., order below); 110-120V, AC when used with tuner pack; or off your car battery (order DC car cord below). UL listed. VCR measures approx. 11½x9½x4½ in. high. See warranty below, right. Delivery Class C—see page 364.

X 855-2218 A—Class C wt. 25 lbs. 1289.00

Portable VHS Video Cassette Recorder with 24-hour Tuner Pack (not shown). Built-in automatic timer lets you program up to 24 hours in advance. Includes all other features described in [A]. See warranty below.

X 855-2234 A—Delivery weight 25 lbs. 1189.00

12V Rechargeable Battery will power portable VCR with Custom Deluxe Color Camera [B] approximately 45 min. Order two or more batteries, so that you will always have one ready to use.

X 855-2317 A—Delivery weight 3.25 lbs. 39.00

9-ft. DC Car Cord for portable VCR. Plugs into cigarette lighter.

X 855-2325 A—Delivery weight 1 lb. 14.75

B Custom Deluxe Color Camera with 6:1 Power Zoom Lens for close-ups and wide-angle shots. Produce your own TV Shows and "instant" movies in full sound and living color. When shooting indoors, additional lights may be needed. Built-in directional microphone with windscreen. F/1.8 lens with electronic viewfinder. Instant playback feature lets you watch what you've just recorded. Rewind the tape. Press the play button and the picture appears automatically in the viewfinder. LED light to indicate camera recording. On-camera recording pause control. Pistol-grip handle and wrist strap. UL listed. Plastic cabinet measures 13½ x 3½ x 11 in. high. 10-ft. cable included. Order extra cable below. (Maximum of 2 additional cables can be used.) See warranty below right.

X 855-2564 A—Delivery weight 18 lbs. 889.00

20-ft. Extension Cable for Camera.

X 855-2614 A—Delivery weight 1.80 lbs. 57.95

Blank VHS (Video Home System) Cassettes are erasable and reusable. Knock-out safety tabs make it virtually impossible to erase material accidentally.

X 855-1087 A—2-4-6 Hour. Delivery weight 1 lb. 19.00

X 855-1079 A—1-2-3 Hour. Delivery weight 1 lb. 14.00

NOTE: The unauthorized recording of copyrighted TV programs, films, video tapes and other materials may infringe on the rights of the copyright owners and may be contrary to copyright laws.



SAVE \$300

Only Till December 27, 1980 on 7-Day Programmable Video Recorder with 6-Hr. Recording Capability

NOW ONLY **887⁰⁰** After Dec. 27, Order at Reg. Price.

Our VHS Video Cassette Recorder with Built-in Electronic 7-Day Programmer lets you program up to a week in advance. Records up to 6 hours without changing cassettes (sold separately, below left). Electronic deluxe tuner receives all 82 VHF/UHF channels. Electronic program indexing. Includes tape counter with memory switch; remote pause control with 20-ft. cord; direct-drive system for synchronized steady pictures; tracking and dew moisture controls; blank cassette. Microphone jack. Solid die-cast aluminum base. 110-120V, AC. UL listed. 34 watts average power consumption. 19 x 14½ x 7 in. high. See warranty below. Delivery Class C—see page 364. Reduced from our big Fall '80 Catalog—see page 780.

X 855-1673 A—Class C wt. 39 lbs. Reg. \$1187.00; NOW 887.00



1 Film to Tape Converter



2 Carry Case for Portable VCR

1 Film To Tape Converter allows you to convert your home movies and color slides to video cassettes. Transfers images from motion picture or slide-type film projectors to a video cassette in any size format from 8mm to 35mm. Use with camera [B] or similar video cameras. (Camera, projector, cassette not included.) Instructions included.

X 855-1525 A—Delivery weight 13.50 lbs. 139.95

2 Handsome Black Vinyl Carry Case securely holds your portable VCR. Adjustable shoulder strap with pad. Chrome-plated snap enclosures. Rugged reinforced construction and lined interior helps protect unit. Fitted outside pocket holds extra battery pack. Case measures approx. 14 x 9¼ x 5 in.

X 855-2309 A—Delivery weight 2 lbs. 49.00

JCPenney Full 90-Day Warranty

Within ten days of purchase, we will repair, or at our option, replace this JCPenney Video Cassette Recorder, Color Video Camera, Camera Lenses, Electronic View Finder, Video Tuner Pac, or Film/Tape Converter, if it is defective in material or workmanship. Parts and labor are included. Just return it to a JCPenney store with the original packing, carton, and accessories.

For the balance of the 90-day warranty we will repair this JCPenney Video Cassette Recorder, Color Video Camera, Camera Lenses, Electronic View Finder, Video Tuner Pac, or Film/Tape Converter if defective in material or workmanship. Parts and labor are included. Just return it to a JCPenney Product Service Center for service. If a JCPenney Product Service Center is not available in your area, contact a JCPenney store. For the balance of this warranty, see page 363.

JCPenney Limited Additional Parts Warranty

After the first ninety days from the date of purchase, we will for the following three months provide a vidicon (camera pick-up tube) replacement part without charge for the JCPenney Color Video Camera if defective in material or workmanship. Labor of installation is not included. Just return it to the nearest JCPenney facility for prompt service.

After the first ninety days from the date of purchase, we will for the following nine months provide replacement parts (except the vidicon) without charge for the JCPenney Video Cassette Recorder, Color Video Camera, Camera Lenses, Electronic View Finder, Video Tuner Pac, or Film/Tape Converter, if defective in material or workmanship. Labor of installation is not included. Just return it to the nearest JCPenney facility for prompt service. For the balance of this warranty, see page 363.

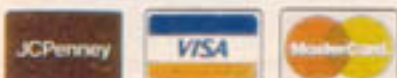

Of Course You Can Charge It—See Page 363

Capture the magic of Photon competition

Score 4 "hits" to win, that's the objective of a Photon Warrior. This double warrior set includes everything you need for target practice or competition between 2 players. Photon Phasers shoot infrared light beams at each other, the target or the helmet from 40 to 50 feet away, day or night. They emit a different sound when fired, hit, hit 4 times or reset, plus they have L.E.D.'s that light up when hit. The control-module chest plates attach to the helmets and Phasers and emit the same sounds as the Phasers. Adjustable Photon helmets (one red, one green) have flashing L.E.D.'s, plus a tube that connects to the control module for transmitting sound to helmet if it is "hit" by Phaser beam. 4x4-inch practice target has randomly flashing lights to signal when it will accept a hit. Fully adjustable Photon belts have a holster for the Photon Phasers. Photon passports have space for a Photon Warriors name, address and Photon name. Not compatible with Lazer Tag, sold below. Requires three 9-volt batteries and 12 "AA" batteries, sold separately on page 404. Warranted by manufacturer; write for free copy, see page 371. For ages 7 and up. 49 N 26229—Shpg. wt. 13 lbs. 8 oz. . . Set \$124.99

Single warrior set for 1 player. Similar to above, with one Photon Phaser, one control module chest plate, one helmet, one practice target, one belt and one passport (not shown). Requires two 9-volt batteries and 6 "AA" batteries, sold separately on page 404. 49 N 26225—With green helmet
49 N 26227—With red helmet
Shpg. wt. 6 lbs. 11 oz. . . Set \$72.99

Double target set. Similar to (1) above, with two Phasers, two belts, two passports and one practice target (not shown). Requires three 9-volt batteries, sold separately on page 404. 49 N 26223—Shpg. wt. 2 lbs. 6 oz. . . Set \$64.99

Single target set. Similar to (1) above, with one Phaser, one practice target and one passport (not shown). Requires two 9-volt batteries, sold separately on page 404. 49 N 26221—Shpg. wt. 1 lb. 9 oz. . . Set \$44.99

The game of tag moves into the future with Lazer Tag™

2 thru 6 Say "Tag, you're it!" from almost 40 to 50 feet away using infrared technology. Imported. Warranted by manufacturer, write for free copy, see page 371. Not compatible with Photon Phaser, sold above. For ages 8 and up.

2 With the Lazer Tag™ game you get one StarLyte™ hand unit that emits an infrared light beam; one StarSensor™ with oscillating L.E.D.'s for nighttime visibility and for scoring tags, plus a variable heartbeat sound that accelerates with each tag; and an adjustable StarBelt™ that holds the StarSensor™. Requires 6 "AA" and one 9-volt battery, sold separately on page 404. 49 N 26202—Shpg. wt. 5 lbs. 6 oz. . . \$44.99

3 The futuristic, adjustable StarVest™ is designed to hold one StarSensor™ (StarSensor™ sold in set above, or separately below). 49 N 26204—Shpg. wt. 2 lbs. . . \$17.99

4 The StarSensor™ has oscillating L.E.D.'s for nighttime visibility and for scoring tags, plus a variable heartbeat sound that accelerates with each tag. Requires one 9-volt battery, sold separately on page 404. 49 N 26206—Shpg. wt. 2 lbs. 4 oz. . . \$19.99

5 The StarHelmet™ has a 360° sensor and oscillating L.E.D.'s for nighttime visibility and for scoring tags, plus a variable heartbeat sound that accelerates with each tag. Requires one 9-volt battery, sold separately on page 404. 49 N 26210—Shpg. wt. 4 lbs. 8 oz. . . \$36.99

6 The StarCap™ has a 360° sensor, plus L.E.D.'s and sound to register tags. Requires one 9-volt battery, sold separately on p. 404. 49 N 26212—Shpg. wt. 2 lbs. 8 oz. . . \$19.99

ages 4 years
and up



A

save \$20

A Type-Right™ Electronic. Full size typewriter keyboard with 8-character display screen teaches and tests both accuracy and speed. Has 9 built-in typing lessons, instruction booklet. Includes English cassette for vocal instruction. Abt. 6¼ x 12 x 2¼". For ages 9 and up. Requires 4 'C' batteries*, not incl. 492 541 049—Sears reg. 89.99. Each 69.99



B

B Petite 990 Typewriter. Authentic 4-row, 80-character keyboard. Easy-type keys; types capital letters. Reversible ribbon incl. Detachable carry case. Abt. 13½ x 12¼ x 5½". Ages 7 and up. 492 527 094 D—English keyboard. Ea. . . . 59.99
492 527 095 DT—French keyboard. Ea. . . . 59.99

C Save On Two replacement ribbons for item B. 'No-mess' reversible carbon. 492 527 096—Each 6.99; 2/11.00



C



D

E

D 'My First Typewriter' with alphabetic keyboard. Ideal to aid spelling, reading and alphabet teaching. Just like the real thing. Abt. 11 x 11 x 3¼". For ages 5 and up. 492 527 827 D—English keyboard. Ea. . . . 34.99
492 527 828 DT—French keyboard. Ea. . . . 34.99

E Replacement Ribbon for item D. 492 527 832—Each 2.99; 2/5.00

F Speak & Spell™...3-star rated, details on page 373. Helps students in spelling, pronunciation, word recognition. 4 skill levels. For Ages 6-14. Uses 4 'C' batteries*, not incl. 492 541 017—English. Each 64.99
492 541 018 T—French. Each 64.99

G Learning Clock. Teaches time, colors, numbers. Bright colorful graphics. Dependable quartz accuracy to within one minute per day. 10" diameter, large easy-to-read dial. For ages 4 and up. One 'AA' battery* required, not incl. 492 541 188—Each 34.99

*Batteries sold on page 398



F



G



Hi-tech looks . . . to tell time and much more

\$2 to \$15 less thru December 15th

1 From ship to shore you'll want this lightweight navigator's quartz watch. Digital analog chronograph with adjustable stainless steel bracelet. Imported. Warranted by Nelsonic*.
4 E 17047—Shipping weight 9 ounces.
Thru 12/15 \$24.99 . . . After 12/15 \$39.99

2 Thin calculator digital watch is water-resistant to 30 meters†. Time readout includes day/date. 4-function calculator and alarm. Black plastic case and strap. Imported. Warranted by Innovative Time*.
4 E 45484—Shipping weight 2 ounces.
Thru 12/15 \$9.99 . . . After 12/15 \$12.99

3 Digital alarm chronograph quartz watch is water-resistant to 30 meters†. Month, day, date readout. 7-year warranted battery. Black plastic band. Imported. Warranted by Innovative Time*.
4 E 45485—Shipping weight 4 ounces.
Thru 12/15 \$12.99 . . . After 12/15 \$15.99

4 Sport Master digital watch is water-resistant to 50 meters†. Includes 24-hour stopwatch countdown pacer to set stride and estimate distance; day, date, month and alarm. Black plastic case and band. Imported. Warranted by Innovative Time*.
4 E 45486—Shipping weight 3 ounces.
Thru 12/15 \$19.99 . . . After 12/15 \$24.99

5 Men's analog digital quartz watch is water-resistant to 200 meters (can withstand 1 ton of pressure)†. Displays time, month, day, date; alarm feature. Stainless steel case and band. Imported. Warranted by Innovative Time*.
4 E 17361—Shipping weight 6 ounces.
Thru 12/15 \$49.99 . . . After 12/15 \$59.99

6 Quartz watch is water-resistant to 100 meters†. Countdown timer, alarm, chronograph, hourly and hourly chime. Time readout includes month, day, date. Black plastic with stainless steel back. Imported. Warranted by Casio*.
4 E 45681—Shipping weight 4 ounces.
Thru 12/15 \$20.99 . . . After 12/15 \$29.99

7 Men's quartz analog with plastic sport grid case. Second hand; 24-hour military time dial. Imported. Warranted by Casio*.
4 E 17061—Shipping weight 3 ounces.
Thru 12/15 \$20.99 . . . After 12/15 \$29.99

8 Analog digital quartz is water-resistant to 50 meters†. Alarm chronograph displays month, day, date. Black plastic case and band. Imported. Warranted by Casio*.
4 E 17041—Shipping weight 3 ounces.
Thru 12/15 \$24.99 . . . After 12/15 \$34.99

*Write for free copy, see page 371.
†See water-resistant note, page 216

9 6-Digit stopwatch displays month, day, date on command. Records up to 1/100th second up to 24 hours. Black plastic case with nylon neck cord. Imported. Warranted by Criterion*.
4 E 19107—Shipping weight 3 ounces.
Thru 12/15 \$6.99 . . . After 12/15 \$9.99

10 Piano watch has full musical scale. Video space game with missile launch and digital scorekeeper. 4-function calendar. Time readout with date, alarm, hourly chime and 24-hour military time readout. Silver-color plastic with stainless steel back and band. Imported. Warranted by Armitron*.
4 E 45166—Shipping weight 5 ounces.
Thru 12/15 \$17.99 . . . After 12/15 \$19.99

11 Memo Phone™ watch memorizes up to 42 individual ten-digit numbers for phone, credit cards, etc. 4-function calculator. Time readout includes month, day, date. Alarm and 24-hour military time. Silver-color plastic with stainless steel back and band. Imported. Warranted by Armitron*.
4 E 45168—Shipping weight 5 ounces.
Thru 12/15 \$24.99 . . . After 12/15 \$29.99

12 8-digit calculator alarm watch shows day, date. Base metal case with adjustable band. Imported. Warranted by Nelsonic*. Shpg. wt. 3 oz.
4E45082—Chrome-plated 4E45081—Gold-color
Thru 12/15 \$9.99 . . . After 12/15 \$14.99

When you can't go home for Christmas, send Christmas home with Ship-A-Gift . . . see page 374.



In "Alphabet Fun," a friendly electronic voice and colorful pictures help children identify words, letters and objects.



"Numbers Fun" introduces your child to numbers in a delightful way.



"Animal World" helps children learn the names of animals and where they live.



Each additional program comes boxed in a package of 5 cards.



1. *Dial A Teacher* is a talking toy that helps prepare your child for early school years. By "dialing" up questions on the telephone dial, kids can learn the basics of spelling, math, music and more. Answers are punched in on the touch-pad keyboard. To change the subject, just remove one card and clip in another (5 cards included). Automatically shuts off after 2 minutes of non-use. Requires 3 "C" batteries, sold separately on p. 459. Additional programs available at right. For ages 4 to 8 years. Warranted.*
49 C 17901—Shipping weight 3 pounds...\$39.99

2 thru 4. *Additional programs for (1)*. Each includes a cartridge and 5 overlays.
For ages 4 to 8 years.
2. 49 C 17902—Alphabet Fun
3. 49 C 17903—Number Fun
4. 49 C 17904—Animal World
Wt. 1 lb. 2 oz. ...Ea. \$12.99



6



7



8



9

5. *The Whiz-Kid video learning toy* simulates home-computer excitement. Uses colorful graphics and a clear LCD readout to teach a variety of subjects. Through games and gentle musical encouragement, your child is exercised in math, spelling, music, general knowledge and much more. Includes a built-in cartridge and 50 "input" cards. Additional learning programs are available below. Keyboard folds in and includes a shoulder strap, making the Whiz Kid a snap to take anywhere. Requires 4 "C" batteries, sold on page 459. For ages 6 to 10 years. Warranted.*
49 C 17739—Wt. 2 lbs. 5 oz. ...\$48.99

6 thru 9. *Additional learning programs for (5)*. Include a cartridge and 50 "input" cards. For ages 6 to 10 years.
6. 49 C 17742—Alpha Fun
7. 49 C 17743—Word Fun
8. 49 C 17744—Cross Word
9. 49 C 17746—Number Fun
Shipping weight 8 ounces. ...Each \$12.99
*Write for free copy, see page 335.



COMPUTER CHESS

Formidable opponents and patient instructors

(1 thru 3) Full-size playing fields actually sense your moves automatically. No distracting buttons to push... move your pieces in the traditional way. Play an opponent and the computer monitors all moves. Play the computer and it suggests moves or shows moves it is considering. Even thinks on opponent's time for faster response. Built-in chess clock times each player. UL listed for 110-120-v., 60 Hz. AC. Warranted by manufacturer; to write for free copy, see page 323.

(1) Fidelity's Sensory Chess Challenger has 9 selectable skill levels. Features a special easy mode that weakens all levels without changing time controls. Powered by 16K of ROM (read only memory) for strategy; 2K RAM (random access memory) for playability. Officially U.S.C.F. rated playing strength of 1771 points. Indicates moves with lights and tones. Take back feature reverses up to 15 half moves. Durable molded plastic housing with built-in storage for pieces. Adapter included or requires 4 "C" batteries, not included, sold on page 595. 49 C 65647—Shipping weight 3 lbs.\$169.99

(2) Fidelity's Elite Auto Sensory Chess Challenger actually tells you its next move. Electronic voice has 50 word vocabulary. 28K of ROM (read only memory) powers 15 selectable skill levels including book openings. Fidelity estimates playing strength of 1950 U.S.C.F. points. 4K of RAM (random access memory) for challenging playability. Take back feature reverses up to 35 half moves. Handsome handcrafted nutwood pieces and housing with inlaid play field. Adapter included. O 49 C 65639C—Shpg. wt. 7 lbs.\$399.99

(3) Milton Bradley's Ambassador Chess Computer solves problems and mating combinations on 2 skill levels. Also has 5 selectable skill levels with or without tournament timing. 24K of ROM (read only memory) for strategy; 4K of RAM (random access memory) for playability. Lights and sounds indicate computer's moves pleasantly. Take back feature reverses completely back to opening to replay entire game. Handsome hand-crafted nutwood pieces and housing with inlaid play field. Adapter included. O 49 C 65694C—Shpg. wt. 19 lbs.\$299.99

(4) Comuta-Chess from Hanimex plays either side on 8 selectable skill levels. Indicates moves in traditional way on 3½-inch square play field. Durable plastic housing, pieces and carrying case. Requires one 9-volt battery, not included, sold on page 595. Warranted by manufacturer; to write for free copy see page 323. 49 C 65601—Shipping weight 1 lb.\$29.99

(5) Need a partner for bridge? Bridge Challenger® is programmed with all the best-known conventions and will play as your partner or up to all 4 hands at once. Powered by 1K RAM (random access memory) for strategy; 24K ROM (read only memory) for playability. Electronic scanner "reads" special cards. Includes 3 felt playing fields, 2 decks of custom cards and deluxe carrying case. Hardwood housing is 13½x8½ inches. UL listed for 110-120-volts, 60-Hz., AC. Adapter included. Warranted by Fidelity; to write for free copy, see page 323. Was \$149.99 in our 1982 Christmas Book, page 635. 49 C 65641—Wt. 7 lbs.. Now \$99.99

(6 and 7) Hand-held Electronic Casino Games. Plastic housing. Requires 4 "AA" batteries, not included, sold on page 595. For ages 8 years and up.

(6) With 5-card Stud Poker you have 3 chances to bet. You and the computer can opt to call, bluff, fold or double the bets. 49 C 65105—Wt. 1 lb.\$19.99

(7) Electronic 10-card Gin Rummy and "21" Blackjack. 49 C 65106—Wt. 1 lb.\$19.99

Buy (6) and (7) together and save \$4. 49 C 65107—Wt. 2 lbs.\$35.98



Portable Comuta-Chess even includes carrying case
Only 6¾x4½ in. wide

WISH BOOK VALUE

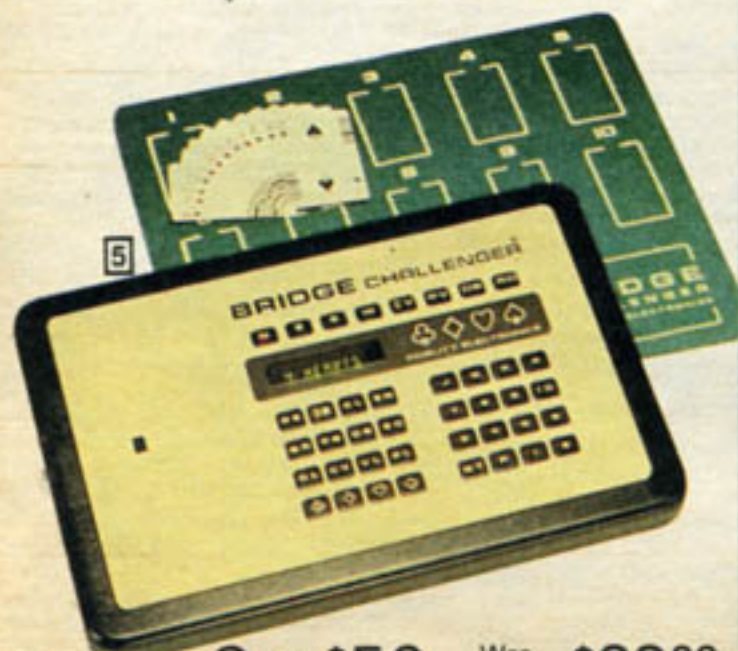

WISH BOOK VALUE



Save \$4 when you buy both

Separate prices total \$39.98

\$35.98

Cut \$50 Was \$149.99 \$99.99



A



B



C



D



E



F



G



H



I



J



K



K



L



M

A Turntable Tripoley® makes it easy to place bets or collect winnings!
FEATURES: No more stretching across the table, since game tray is mounted on ball-bearing turntable. Storage spaces for cards; chips included.
 48 T 14318 G—AGES: 12 and up. Ship. wt. 3 lbs. 11.98

B Card shuffler thoroughly shuffles 2 decks of cards automatically. Uses 2 "C" batteries, not incl.; order on page 380. Ship. wt. 1 lb. 5 oz.
 48 T 14316 D—SAVE \$2 when purchased with (A) 10.99; singly 12.98

C Chinese Chess™ . . . game of a thousand surprises. Plan it like chess, play it like checkers. AGES: 8 and up.
 48 T 14267—Ship. wt. 1 lb. 8 oz. 8.27

D Can't Stop™—a game of luck for the whole family to enjoy.
 48 T 14538—AGES: 10 and up. Ship. wt. 1 lb. 13 oz. 8.27

E Deluxe Rummikub is a combination of Rummy, Canasta and Mah Jongg. Stores in sturdy, woodgrained-look case. AGES: 8 and up.
 48 T 14394—Ship. wt. 4 lbs. 18.99

F Connect Four®—the fast-moving game of vertical checkers, it's one strategy game with plenty of ups and downs! AGES: 7 and up.
 48 T 14309—Ship. wt. 1 lb. 13 oz. 7.44

G Beware! Rubik's Cube and Missing Link are two puzzles guaranteed to test the best. Millions of combinations but only one solution each.
 48 T 14801—AGES: 8 and up. Ship. wt. 1 lb. 1 oz. both 10.79

H Inner Circle™ . . . survive to the inner circle and win! Maneuver pawns into holes in each of 4 layers of game boards.
 48 T 14279—AGES: 8 and up. Ship. wt. 1 lb. 10 oz. 6.97

I Kid Kong, The Ape Escape Game.™ Chain the beast! But beware, one will release and Ape "escapes"—throws off chains! 1-8 players.
 48 T 14659—AGES: 4 up. Made in Hong Kong. Ship. wt. 1 lb. 8 oz. . . 8.99

J 52 all-time great games in one box. Play chess, checkers, tic-tac-toe, backgammon and 48 more favorites. Includes playing pieces, instructions.
 48 T 14278—AGES: 8 and up. Ship. wt. 2 lbs. 8.99

K Picture Tri-Ominos . . . match pictures and numbers to play this three-sided domino game. No reading necessary. AGES: 4 and up.
 48 T 14243—Ship. wt. 1 lb. 5.97

L Spellbound lets you turn to a whole new word game.
FEATURES: 4 rapid fire word games and 2 challenge levels.
 48 T 14253—AGES: 9 and up. Ship. wt. 8 oz. 6.99

M Regular Monopoly.® Standard version of the world's most popular game.
 48 T 14201—AGES: 8 and up. Ship. wt. 2 lbs. 9 oz. 7.47
 48 T 14041—Anniversary Ed. Monopoly. Wt. 3 lbs. 5 oz. 14.99

N Set of 6 fun and educational games for children 4 to 8 years old.
 48 T 14275—Ship. wt. 3 lbs. set 10.99



All 6 games for 10.99

N

Complete Entertainment System



4-Way Power Capability

- AC—line cord (incl.)
- DC—10 "D" cell batteries (not incl.)
- 12 volt DC—car adapter (incl.)
- Rechargeable battery (optional)

Now you can have it all!
Listen to AM/FM radio, your favorite cassettes or watch TV with this lightweight, portable system



249⁹⁹
Each

"Feather Touch" stereo controls

Why settle for less? This TV/AM/FM Stereo/Cassette portable is perfect for the beach, the game, in your car or at the cottage! Comes with detachable speakers for true stereo sound and a separate built-in speaker for easy portability. Television receives both VHF and UHF channels. Cassette recorder/player has stereo "Feather Touch" controls.
578 520 908 DL—Each 249.99
Get yours today—offer ends Dec. 12!

FUN 'N' GAMES



D Two great family card games. O'NO 99™—avoid getting 99 points or more, or you lose. For 2 to 8 players. UNO®—be the first to score 500 points and win. For 2 to 10 players. More games on pages 486, 487. 48 T 14817—AGES: 7 and up. Wt. 12 oz. . . . both 5.00

E Set of 9 "Little House" Books. Illustrated stories by Laura Ingalls Wilder in which she describes her family's life and adventures in pioneer days. See more children's books on pages 306, 307. 53 T 159—Ship. wt. 4 lbs. 3 oz. . . . set 16.97

F Colt-style revolver features a steel frame. Engraved steel cylinder; 7½-in. rifled steel barrel. Walnut grips. .36 caliber, 13 in. long. Kit comes assembled and timed; needs finishing. Shoots black powder. Made in Italy. See Gun Sale Policy pg. 384; more guns on pgs. 372, 373, 383-386. Wt. 2 lbs. 9 oz. 60 T 11046—Revolver kit 69.99
60 T 11014—Finished revolver 94.99

G Sports Pouch™ is an air-cushion carryall that protects fragile equipment. It's waterproof, shock-resistant. Keeps 10 lbs. of equipment afloat. 14x12 inches. See more sporting equipment 362-391. 60 T 53562—Ship. wt. 1 lb. 14.88

H Strolling bowling by Tomy®. Open the compact case, there's your bowling alley complete with wind-up bowling ball and pins. More games on pages 480-491. 48 T 14742—AGES: 5 and up. Ship. wt. 8 oz. . . 5.55

J, K YOUR CHOICE 49.97. Computerized electronic games . . . lightweight and portable for home or travel. Each needs a 9-volt battery (not incl.). Order on page 380. More electronic games pgs. 482-484.

(J) Electronic Chess. 7 levels of play; problem solving mode; position verification; En Passant capture; pawn promotion; LED readout. Won't permit illegal moves. Incl. 8-in. magnetic board, magnetic pieces. 53 T 2798—Ship. wt. 1 lb. 8 oz. 49.97

(K) Omar I Electronic Backgammon. Unlimited levels of play . . . even up to "Tournament" class. Has doubling cube; score keeping; electronic random dice roller; position verification; LED readout. Includes 9-inch magnetic board with magnetic pieces. 53 T 2797—Ship. wt. 2 lbs. 49.97

L Yorktown cannon features wooden carriage, 4-in. steel-rimmed wheels, smooth-bore 5¼-in. brass plated steel barrel. Overall length 9 in. Shoots black powder and .490 round balls. Kit requires assembly, staining. See Gun Sale Policy, pg. 384, more guns and accessories pgs. 372, 373, 383-386. Send for free copy of Manufacturer's Warranty, see pg. 322. 60 T 11022—Cannon kit. Ship. wt. 2 lbs. . . . kit 49.99
60 T 11012—Finished cannon. Ship. wt. 2 lbs. . . 59.99

M SAVE 5.53. "555" 110-camera has built-in electronic flash. Up to 200 flashes per set of "AA" alkaline batteries, not included; order on page 380. Battery check. Taiwan. Write for free copy of Mfr.'s Warranty, see page 322. Cut from '80 Fall Book, page 569. See more cameras on page 13, 327. 67 T 42 LS—Ship. wt. 12 oz. . . . was 25.50; now 19.97

N Sportsman's spyglass is a 25 power telescoped Brown leatherette cover, brass-color trim. Vinyl carrying case with wrist strap and belt loop. Opens from 5¼ to 14¼ in. More sporting equipment pgs. 362-391. 60 T 12096—Ship. wt. 1 lb. 29.99

O Canvas tote bag with Mickey and Minnie Mouse. Reinforced zipper. 11½x10¼x10 in. high. For children's and small size adult skates (to men's 8). 60 T 23756—Ship. wt. 1 lb. 8 oz. 9.99

P Kids love Disney skates with Mickey and Minnie Mouse designs on each vinyl boot! They feature polypropylene sole plates, replaceable toe-stops, die-cast axle housing. 1½x1½-in. vinyl wheels. State full boy's sizes: 12, 13, 1, 2, 3, 4, 5. Note: sizes 12-3 are same for boys and girls; size 4 is girl's 6, size 5 is girl's 7. See more skates and accessories on pgs. 376, 377. Z 60 T 23581—Taiwan. Ship. wt. 8 lbs. pair 34.99



A Christmas convenience—charge it 3 ways!



As seen on TV



PARKER BROTHERS



A Dizzy Dolphins™ . . . toss marbles from a little catapult toward the bobbing dolphins as they dance by. Uses 1 "D" battery, not incl.*
48 T 14071—Plastic. Ages 3 and up. Ship. wt. 2 lbs. 4 oz. 12.88

B Push Over™ is a race for fun as players move piggyback pieces around a curved track and try to be the first to collect ten chips.
FEATURES: Slide, bump, push along to the roll of one, two or three dice. Built-in storage area. AGES: 6 and up.
48 T 14062—Ship. wt. 1 lb. 7 oz. 7.99

C Run Yourself Ragged™ is a race between you and the clock.
FEATURES: Plastic course has 5 obstacles, timer and finish line bell.
48 T 14529—AGES: 5 and up. Ship. wt. 1 lb. 12 oz. 14.44

D Digital Daredevil™ is all the fun of daredevil motocross racing: jump the car and the barrels. You control the speed and jumping motion, but you'll lose time and points for a bad jump. Uses two "C" batteries.*
FEATURES: Automatic scoring, timer and speed controls.
48 T 14063—AGES: 6 and up. Ship. wt. 1 lb. 18.88

E Hit and Missile™—the more aircraft you shoot down and the higher the plane's altitude, the higher your score.
FEATURES: Automatic digital scoring, missile control button. Timer has reset button. Uses 2 "C" batteries, not included.*
48 T 14061—Ages 6 and up. Ship. wt. 1 lb. 3 oz. 18.88

F Contraption™—the fun of a maze and excitement of mechanics.
FEATURES: Flip the power switch and gears start turning. The marbles then roll into the higher gears at either end. Be the first to trap all your marbles in your high gear. Uses 2 "D" batteries, not incl.*
48 T 14698—Ages 6 and up. Ship. wt. 1 lb. 3 oz. 10.98

G Digital Derby™—auto racing game. Steer the course without a collision and accumulate laps; hit a car, alarm flashes making you lose both time and laps.
FEATURES: Automatic lap counter, timer and speed control. Uses 2 "C" batteries, not incl.*
48 T 14059—Ages 6 and up. Ship. wt. 1 lb. 15.88

H Toothache—probe with a very steady hand or you'll hear loud screams from the patient! Uses one 9-volt battery, not incl.*
48 T 14824—Ages 6 and up. Ship. wt. 1 lb. 14 oz. 9.99

I Blip™—futuristic table tennis to play with a pal or alone.
FEATURES: Automatic digital scoreboard. Uses 2 "AA" batteries.*
48 T 14009—Ages 6 and up. Ship. wt. 1 lb. 3 oz. 10.88

J Operation®—The patient may have funny ailments but don't laugh too hard. One slip and you'll be hearing from him! Uses 2 "C" batteries, not included.*
48 T 14853—Ages 6 and up. Ship. wt. 1 lb. 11 oz. 7.97

K Baboon Ball™—new from Hasbro! Comical baboons are made to spin around and run in and out. Swing their hockey sticks to protect your own goals while hitting the ball into your opponent's.
48 T 14896—Ages 6 and up. Ship. wt. 4 lbs. 12.99

*Batteries not included; order on page 380 of this book.

U.S.S. ENTERPRISE 15⁹⁹



Full view of U.S.S. Enterprise play case

ONLY AT WARDS **1.99** EACH **SAVE 20%** WHEN YOU BUY ANY 3





1
Deluxe
Electronic
Football

34⁹⁷

Continuous information displayed on LED read-out—all at your fingertips

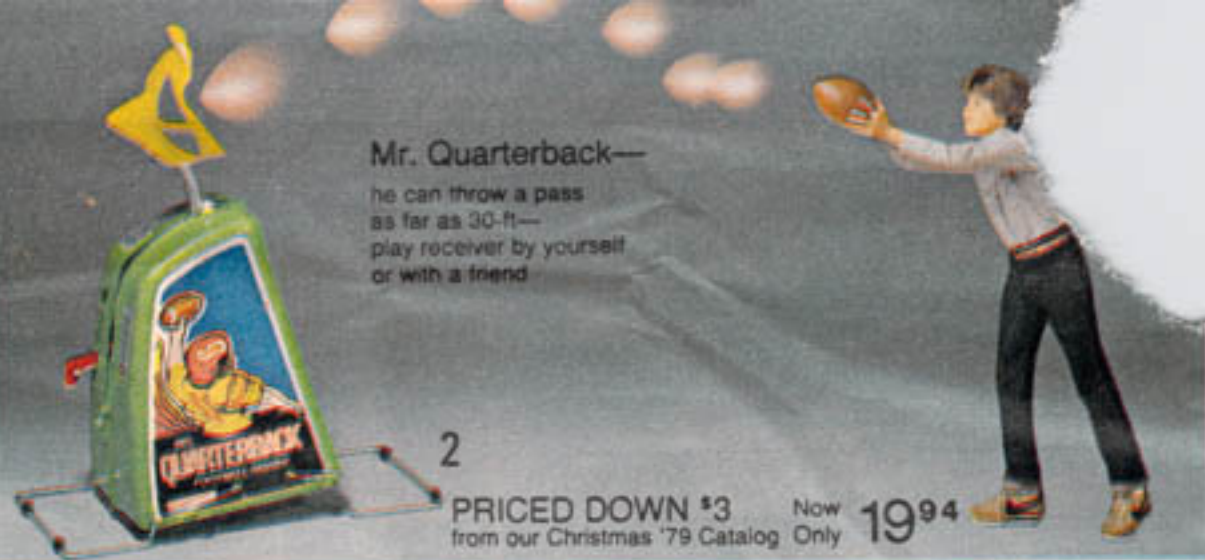

Mr. Quarterback—

he can throw a pass as far as 30-ft—play receiver by yourself or with a friend

2

PRICED DOWN \$3 Now **19⁹⁴**
from our Christmas '79 Catalog Only



NFL Electric Football with Total Team Control

3
22⁶⁶
Set



4 **16³⁷**
Set



NFL Teams come with players molded in 5 different positions

1 NFL Deluxe Electronic Football. All the strategies, kicking, running, and scoring possibilities of NFL football in a hand-held computer! Individual 4-way direction control of quarterback and receiver—alter receiver patterns, scramble your quarterback from rushing linemen. Continuous LED read-out display of down, yards to go, time left in quarter, field position—even four skill levels! 2-minute warning sounds before half and end of game. Uses 4 "AA" batteries—not included, sold on page 461. Plastic housing, 6½x4½x1 in. high. For 1 or 2 players, ages 8 to adult.
XU 923-8817 A—Del. wt. 0.50 lb **34.97**

2 Mr. Quarterback Football Passer. Catch a perfect spiral pass from as far as 30-ft! Play by yourself, one on one, or with a whole team. Angle and distance selectors so you can receive straight or high arc, short or long, passes. Ratchet-lock release on time-delay mechanism means no pass is thrown till you're in position. Plastic and steel. 11x18½x18½ in. high. Lightweight plastic football included. Ages 6 and up. Was \$22.94 in our Christmas '79 Catalog.
XU 925-3659 A—Del. wt. 5 lbs **NOW 19.94**

3 & 4 Total Team Control Football.* Just set the wheel in the base of each player for direction, adjust speed control on the field, switch on the game, and watch the vibrating metal field start the action. Automatic timer starts and stops with each play. Includes 22 plastic players (enough for 2 full teams) molded in 5 different 3-D poses in NFL team colors. Triple-threat quarterback can kick, pass, and run. Magnetic down marker with movable 10-yard marker, magnetic ball, plastic goal posts, 4 plastic goal line flags. Scoreboard on grandstand is paper board. Easy-to-apply numbers, 2 through 89. Order additional NFL teams at right. Ages 8 and up.

[3] NFL Super Bowl. 16¼x32½ in.-wide playing field, 34¼x18½x3 in. high overall.

XU 923-0004 A—Del. wt. 9.50 lbs. Set **22.66**

[4] NFL Football. 13x24 in.-wide playing field, 26½x15¼x1¼ in. high overall.

XU 923-0012 A—Del. wt. 4.50 lbs. Set **16.37**

Of Course You Can Charge It—
See Page 363

NFL Teams. All 28 teams in official team colors with decals. Each 11-player team included with sets [3] and [4] has both black and white players molded in 5 different 3-D poses. Order teams by Conference and Division. NATIONAL CONFERENCE: East Division (Cardinals, Cowboys, Eagles, Giants, Redskins); Central Division (Bears, Buccaneers, Lions, Packers, Vikings); West Division (Falcons, 49'ers, Rams, Saints). AMERICAN CONFERENCE: East Division (Bills, Colts, Dolphins, Jets, Patriots); Central Division (Bengals, Browns, Oilers, Steelers); West Division (Broncos, Chargers, Chiefs, Raiders, Seahawks). Del. wt. 0.80 lb. each.

National Conference Teams.	
XU 924-9855 A—Eastern	11.97
XU 925-9045 A—Central	11.97
XU 925-9052 A—Western	9.97
American Conference Teams.	
XU 924-9889 A—Eastern	11.97
XU 924-9897 A—Central	9.97
XU 925-9060 A—Western	11.97



5
17⁸⁸

5 NFL Strategy Football. The Probability Selector determines statistically correct results for the plays you mastermind. Set includes plastic game case with adjustable scoreboard, play selector, and 14¼x8¾-in. playing field with football marker. In addition, there's an NFL playbook, and 34 offensive and 12 defensive play diagrams. For 2 players, ages 12 and up. See special NFL index on page 371.
XU 924-9848 A—Del. wt. 3 lbs. **17.88**



6
14⁶⁶

6 Instant Replay Football. Press "play action" button, and see your play on screen. Then press "defense" button, and find out how successful you were. Includes run, pass, p.a.t., punt, and kick button features. Mini-football field has ball marker for manual field position. "Stadium scoreboard" on top indicates down, yards to go, time to go, and teams. Plastic. 9x6x9 in. high. Uses two "C" batteries—not included, sold on page 461. For 1 or 2 players, ages 8 to adult.
XU 923-8858 A—Del. wt. 1.75 lbs. **14.66**



7
13⁹⁷

7 Electric Baseball Action! The pitcher throws strikes and change-ups. The realistic bat lets the batter bunt, hit singles, doubles, triples, and home runs. The players run the bases, and the fielders can throw men out at any base. Metal game board, grandstand, and scoreboard. Four realistic plastic 3-D base runners, and ball, 19½x19½x2 in. high, including stadium backdrop. For ages 8 to adult.
XU 925-1620 A—Del. wt. 4.25 lbs. **13.97**

*UL listed for 110-120 volts, AC. Caution: electric toy—see note on page 465.

Now the TI 99/4A can respond to your voice and even talk back

TI 99/4A Computer
\$50 REBATE from Texas Instruments
\$149.99 full price | **\$99.99** after rebate

Talk to your TI 99/4A! Yes, that's right. The TI 99/4A with the MBX Expansion System will actually respond to your voice commands while playing any one of the ten exciting games sold below. Each game offers unique challenges and amazing play options for all ages. All programs are Solid State Speech Cartridges with speech synthesis and/or voice recognition built-in.

Begin with the TI 99/4a Computer

(1) It comes with 16K memory and will expand up to 52K with the addition of peripheral items sold in the 1983 Fall Big Book, pg. 868-69. TI BASIC programming language built right in. 48 alpha-numeric keys on a full-stroke typewriter-like keyboard. Upper/lower case. 16 colors (with color TV), great color and sound. 10 1/2 x 15 x 2 1/2 in. Incl. video modulator, Beginner's Basic Manual, User's Guide. Warranted by Texas Instruments, Inc. Write for free copy, see pg. 323. Price after \$50 REBATE from TI \$99.99. Coupon enclosed. Rebate expires 1-31-84. Void where prohibited.

3 E 23042C—Shpg. wt. 12 lbs. 8 oz. Full price \$149.99

Then add the Milton Bradley MBX Expansion System

(2) System includes: 64 position action-input Keypad that allows more flexibility in control situations. Each voice command cartridge includes dedicated keypad overlays that customize keypad to game. Triple-axis analog Joystick that controls left/right, forward/back and a 360° rotation. Lightweight headset and microphone. (Only for the TI 99/4A).

DO NOT ORDER BEFORE NOVEMBER 15, 1983

3 E 23215C—Shipping weight 3 lbs. \$119.99

Joystick alone. For team-play or, enhance regular game play.
 3 E 23216—Shipping weight 8 ounces. \$39.99



(2) Milton Bradley MBX Expansion System

There's more than fast talk with Programs for the Texas Instruments 99/4A

Milton Bradley Voice Command Solid State Speech™ Cartridges. The following ten titles are playable with or without the MBX System (except the three asterisked titles that must be played with MBX System).
 Terry Turtles Adventure™ (MBX). Guide talkative Terry home. Help him around various obstacles and get him home before his hibernation.
 3 E 23356—Shipping weight 1 lb. ... \$54.99

Space Bandits™ (MBX) Snatch up space crystals in a 3-D maze, chased by deadly droid guards.
 3 E 23251—Shipping weight 1 lb. ... \$49.99

Superfly™ (MBX) Destroy the alien spiders before the next bad batch hatches and gets you good.
 3 E 23352—Shipping weight 1 lb. ... \$49.99

Championship Baseball™ (MBX) Dazzling diamond action with a computer umpire to call the plays and pitches.
 3 E 23350—Wt. 1 lb. ... \$54.99



Championship Baseball™

Sewermania™ (MBX) Diffuse deadly time bombs in a sewer filled with killer rats and alligators. Elude them if you can.
 Shpg. wt. 1 lb.
 3 E 23353... \$49.99

Big foot™ (MBX) He is cornered on a mountain top and hurling giant ice boulders down at you. Dodge 'em.
 3 E 23355—Shpg. wt. 1 lb. ... \$49.99

Honey Hunt™ (MBX) Help our little bee collect nectar from magic flowers. Beware of spiders and dragonflies.
 3 E 23357—Shipping weight 1 lb. ... \$49.99



Meteor Belt™

Meteor Belt. (MBX) Situation crucial! You command galactic outpost under attack by alien forces. Destroy rival ships and radioactive meteors.
 Wt. 1 lb.
 3 E 23354... \$49.99

Sound Track Trolley™ (MBX) Create electronic video music with the help of a group of zany musicians.
 3 E 23358—Shipping weight 1 lb. ... \$49.99

I'm Hiding™ (MBX) Hide-and-seek fun with cute little bugs playing peek-a-boo inside your crayon box.
 3 E 23359—Shipping weight 1 lb. ... \$54.99



Pac Man™

Pac-Man™ Race to gobble up energy dots. Beware of those clever goblins.
 ©Bally Midway Mfg. Co., licensed by Namco-America, Inc. Wt. 5 oz.
 3 E 76386... \$39.99

Defender™ Aliens swarm planet to capture your humanoids. Rescue them. ©Williams Electronic, Inc.
 3 E 76390—Shpg. wt. 5 oz. ... \$39.99

Parsec™ Battle alien ships on a remote planet.
 3 E 76222—Shpg. wt. 10 oz. ... \$39.99

Munchman™ Outmaneuver four hungry hoonos while racing thru a very interesting maze.
 3 E 76075—Shpg. wt. 1 lb. ... \$39.99

Dig Dug™ You frantically burrow underground to escape those ferocious fire breathing dragons.
 ©Namco Ltd.
 3 E 76389—Shpg. wt. 5 oz. ... \$39.99

Shamus™ Use your detective skills to find the SHADOW in his lair. 32 rooms bristling with danger.
 3 E 23218—Shpg. wt. 5 oz. ... \$39.99

Super Storm™ The ground trembles, nature rebels, as wave after wave of slime oozes from the heavens.
 3 E 23219—Shpg. wt. 5 oz. ... \$39.99



Donkey Kong™

Donkey Kong™ Jump barrels, climb ladders, rescue your lady.
 ©Coleco. Wt. 5 oz.
 3 E 76387... \$39.99

Music Maker™ Create computer music by arranging notes on a musical staff. Cassette or Disk System recommended.
 Shpg. wt. 10 oz.
 3 E 76060... \$39.99

TI Invaders™ Your world is under attack by armada of nasty creatures from outer space. Zap them silly.
 3 E 76073—Shpg. wt. 1 lb. ... \$39.99

Centipede™ Hoard of creepy critters invade your mushroom patch. Fire up your trusty "bug blaster".
 3 E 76388—Wt. 8 oz. ... \$39.99



Centipede™

Addition/Subtraction 1™ Basic math skills. Grade 1. Developed in conjunction with Scott, Foresman & Co. Wt. 1 lb.
 3 E 76051... \$39.99

Reading Rally™ Practice on basic reading skills with

stories about the sophisticated topics. 5th grade level. Developed by Scott, Foresman and Co.
 3 E 76203—Shipping weight 10 ounces. ... \$54.99

Reading On™ Teaches skills required to understand maps, graphs and schedules. 3rd grade level. Developed by Scott, Foresman and Co.
 3 E 76201—Wt. 10 oz. ... \$54.99

All programs warranted by individual manufacturer. Write for free copy, see page 323.

*DO NOT ORDER BEFORE OCTOBER 15, 1983

1 Entex Basketball 2. Play against computer or another player. Pass, dribble, lay-up, long shots, rebound, turnover, foul, free throw, out-of-bounds. Sound effects. 2 skill levels. Plastic, 8½x6½x1½ in. Uses 3 "AA" batteries. Ages 6 to adult. Will be \$32.44 on Jan. 24, 1981.
XU 923-9997 A—Del. wt. 0.75 lb. NOW 29.49

2 Entex Electronic Baseball 3. Play against computer or another player. Remote-control pitching throws. 5 different pitches. Bunt, steal, double play, sacrifice flies, foul balls. Two skill levels. Baseball sounds. Plastic, 8½x6½x1½ in. Uses 2 "AA" batteries. Warranted by mfr., see p. 363. 1 or 2 players, ages 8 and up. Will be \$34.77 on Jan. 24, 1981.
XU 924-4872 A—Del. wt. 1 lb. NOW 31.59

3 Entex Soccer. Play against computer or another player. Interceptions, run-downs, turnovers, kicking for goals. Sound effects. 2 skill levels. Plastic, 8½x6½x1½ in. Uses 3 "AA" batteries. Ages 8 and up. Will be \$31.88 on Jan. 24, 1981.
XU 924-4948 A—Del. wt. 1.40 lbs. NOW 28.99

4 Entex Color Football 4. Play against computer or another player. Red and green teams with semi-animated, shaped players—a true football strategy game, with all kinds of realistic play movements. Sound effects. 2 skill levels. Plastic, 8½x6½x1½ in. Uses 3 "AA" batteries. Ages 8 and up. Will be \$47.66 on Jan. 24, 1981.
XU 923-9971 A—Del. wt. 0.75 lb. NOW 44.49

5 Entex Space Invader. Action and sound effects, with animated spacecraft and missile battle. 2 skill levels. Plastic, 8½x6½x1½ in. Uses 6 "AA" batteries. 1 or more players, ages 6 to adult. Will be \$34.99 on Jan. 24, 1981.
XU 925-7726 A—Del. wt. 0.75 lb. NOW 31.88

6 Cadaco Foto-Electronic Bowling. Large-size alley with a full-figure, 3-D bowler you control. Send the ball at the pins for strike, spare, or even a gutter ball. Musical sounds for hits, and a sound count of pins knocked down. Plastic, 17x5x5½ in. high. Uses two 9-volt batteries. For 1 or 2 players, ages 8 and up.
XU 925-7734 A—Delivery weight 2 lbs. 33.49

7 Tomy Blip. Serve the digital blip, then try to return it by pushing the button before the blip crosses the court. Wind-up timer starts the action. Uses 2 "AA" batteries. 1 or 2 players, 7 yrs. and up.
XU 925-3626 A—Delivery weight 0.65 lb. 10.88

8 Tomy Tennis. Electronic tennis with animated players. Play against computer or another player. 6 different full-court games. Control the serves and swing. Rush the net or go back for a lob. 3 skill levels. Plastic, 9½x6¾x2¾ in. high. Uses 4 "C" batteries. Ages 8 and up. Will be \$36.99 on Jan. 24, 1981.
XU 925-7742 A—Del. wt. 1 lb. NOW 32.99

9 Tomy Break Up. Score points by using the balls to break up as many blocks as you can. 2 skill levels with choice of 3 or 5 balls. Plastic, 9½x6½x2½ in. Uses 3 "AA" batteries. For 1 or more players, ages 7 and up.
XU 925-7759 A—Delivery weight 1 lb. 28.99

10 Tomy Digital Derby Auto Raceway. Steer and shift—try to make the most laps before the time runs out. 2 lanes of competition, crash—the alarm flashes, you lose laps. Automatic lap counter. Plastic, 8¾x5½x2½ in. Uses 2 "C" batteries. 1 or more players, 6 years and up. Will be \$16.29 on Jan. 24, 1981.
XU 925-6975 A—Del. wt. 1.25 lbs. NOW 14.59

11 Tomy Digital Diamond. Pitch a ball or strike, batter can hit or miss. Singles, doubles, triples, homers, or out. Plastic, 9x6x2 in. Uses 2 "AA" batteries. For 2 players, ages 6 and up. Will be \$10.29 on Jan. 24, 1981.
XU 923-3693 A—Del. wt. 1 lb. NOW 9.22

12 Tomy Hit and Missile. Release the missile to try and hit the different warplanes flying by. Timing is everything. There's a red flash on each hit. Built-in timer. Plastic, 9½x7½x2¾ in. Uses 2 "C" batteries. For 1 player, 6 yrs. and up. Will be \$19.99 on Jan. 24, 1981.
XU 923-3735 A—Del. wt. 1.20 lbs. NOW 18.49

CONSUMER INFORMATION: ELECTRONIC SPORTS GAMES

By simulating games like baseball or football, sports games help a child develop fine hand coordination and a sense of timing. Some can be won simply by chance; others demand skill in anticipating moves. Most can be played both independently and against an opponent to help a child learn to handle competitive situations. Look for sports games that have several playing options and skill levels to maintain the child's interest as his or her skills develop.

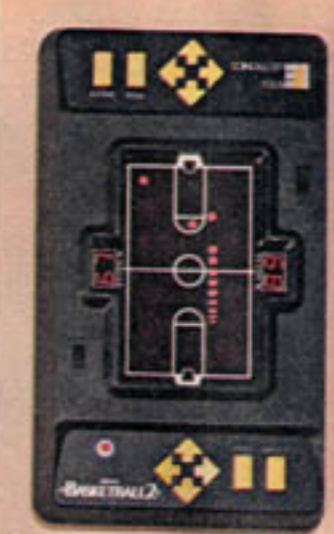

1 Basketball 2 29⁴⁹



3 Soccer 28⁹⁹



6 Cadaco Foto Electronic Bowling 33⁴⁹



7 Blip 10⁸⁸



10 Digital Derby 14⁵⁹



2 Baseball 3 with remote control 31⁵⁹



4 Football 4 44⁴⁹



8 Tennis 32⁹⁹



11 Digital Diamond 9²²



12 Hit and Missile 18⁴⁹

5 Space Invader 31⁸⁸



9 Break Up 28⁹⁹



12 Hit and Missile 18⁴⁹

ENTEX®

TOMY

JCPenney 449



A Space Strike—hit the "planetary target" with your space saucers
12⁸⁸

LCD Digital Clocks plus Games

Your Choice
29⁹⁹ Each
Includes Batteries



C Exterminator



B Fireman
Fireman

D Toss-Up



E Road Rockets
8⁴⁹



F Scan, Strike, 'N' Score
15⁸⁸



G Space War
Light-Up Target Game
12⁴⁹



H Electronic
Battle Command
33⁶⁶



I Toss Across
13⁹⁹

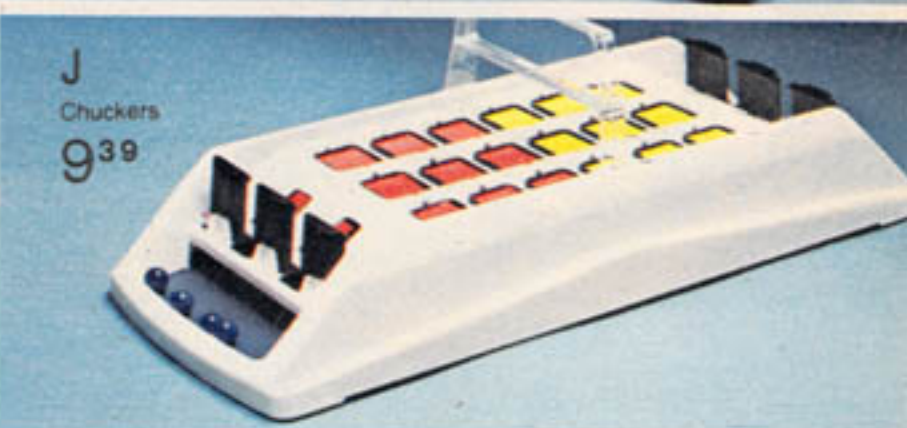

J Chuckers
9³⁹



K Velcro®
Target
Games
5²⁴ each



N SESAME STREET

TAKE YOUR COMPUTER TO THE LIMIT

with quality accessories like these...



Okidata wide-carriage printer

\$349⁹⁹

\$14 MONTHLY, NO PAYMENTS 'TIL JANUARY*



Sears SR 5000 24-pin printer **\$399⁹⁹** thru November 30th only
\$15 MONTHLY, NO PAYMENTS 'TIL JANUARY*

For IBM PC, IBM compatibles and other parallel output computers. For up to 16-in. wide paper. Data, word processing and graphics at 120 CPS; 30 CPS at near-letter-quality. Centronics-parallel interface (order cable below). Double-width characters, 9-pin printhead and vertical tabs. Friction or pin feed. Imported. Warranted.**
3 E 32419L—Wt. 14 lbs ... \$349.99

Black replacement ribbon for (1).
T 3 E 20921—Wt. 1 oz ... \$6.99

24-pin printhead produces letter-quality (LQ) characters plus spectacular graphics. 70 characters per second at LQ, 210 CPS in draft mode. Expanded, italic, bold, superscript, subscript and other characters. Accepts paper up to 10 in. wide. Friction or adjustable pin feed. Centronics-parallel interface (order cable below). Warranted.**
3 E 32422L—Wt. 22 lbs. Thru 11/30/88 \$399.99
After 11/30/88 \$449.99

Parallel printer cable to connect printer (1 or 2) to computer (1) on facing page or (4) on page 617.
T 3 E 20905—Wt. 13 oz ... \$17.99

Okitel 1200 modem **\$199⁹⁹** \$10 MONTHLY, NO PAYMENTS 'TIL JANUARY*



Parallel printer cable connects (1 or 2) to Laser 128 and 128 EX computers sold on page 616.
T 3 E 76653—Wt. 9 oz ... \$16.99

Black replacement ribbon for (2).
T 3 E 20924—Wt. 2 oz ... \$8.99

Magnavox green 12-in. diagonal measure TTL monitor. IBM-type TTL video input, dark anti-glare glass CRT. IBM-compatible interface cable included. Imported. Warranted.**
3 E 32514C—Wt. 17 lbs ... \$99.99

Magnavox EGA color monitor for high-resolution text and graphics in 64 brilliant colors. 13-in. diagonal measure screen has 80-column readability with up to 2000 characters viewable at one time. Anti-glare glass CRT. Order tilt/swivel base below. Imported. Warranted.**
3 E 32515C—Wt. 27 lbs ... \$399.99

EGA (IBM standard) card for (4).
3 E 32516—Wt. 1 lb ... \$159.99

Tilt/swivel base for (4).
3 E 32517—Wt. 2 lbs ... \$19.99

Sears modem **\$149⁹⁹** \$10 MONTHLY, NO PAYMENTS 'TIL JANUARY*



EGA color monitor **\$399⁹⁹** \$15 MONTHLY, NO PAYMENTS 'TIL JANUARY*
Base sold separately

Modems let your computer communicate with others over phone lines. Fully Hayes-compatible. Warranted.*

Okitel 1200 modem. 1200-baud. Imported.
3 E 32430—Wt. 4 lbs ... \$199.99

"SR 1200" 1200-baud modem.
3 E 32428—Wt. 5 lbs ... \$149.99

Cables to connect (5) or (6) to computers.
T 3 E 20911—For Laser 128. Wt. 6 oz ... \$14.99
T 3 E 20910—For any Laser XT. Wt. 8 oz ... \$14.99

3½-in. external disk drive for Laser 128 and 128 EX on page 616. Stores up to 400 pages of text on pocket-sized dual-sided disks. Imported. Warranted.**
3 E 32193—Wt. 2 lbs. 10 oz ... \$229.99

Similar to (7), but for Laser Compact XT on page 617. Stores up to 360 pages of text.
3 E 32194—Wt. 2 lbs. 14 oz ... \$169.99

*See page 305.

**Warranted by Sears or manufacturer. Write for free copy, see page 304.

Note: Catalog numbers with a "T" prefix may take extra time for delivery.

Apple IIe/c-compatible external 3½-in. disk drive **\$229⁹⁹** \$11 MONTHLY, NO PAYMENTS 'TIL JANUARY*





1 Buck Rogers Target Game—projects moving space targets on wall
37⁹⁹



2 Flash—a hit produces a sound and light show
51⁹⁹



Shoot-Out in Space—send the rocket flying

3 PRICED DOWN \$5 from our Christmas '79 Catalog

Now Only 14⁹⁹



Target Games That "Shoot" a Harmless Beam of Light



4 Two-Man Skeet—projects a moving target on the wall
88⁹⁹



5 Quickfire®—3 skill levels, 6 different games
57⁷⁷

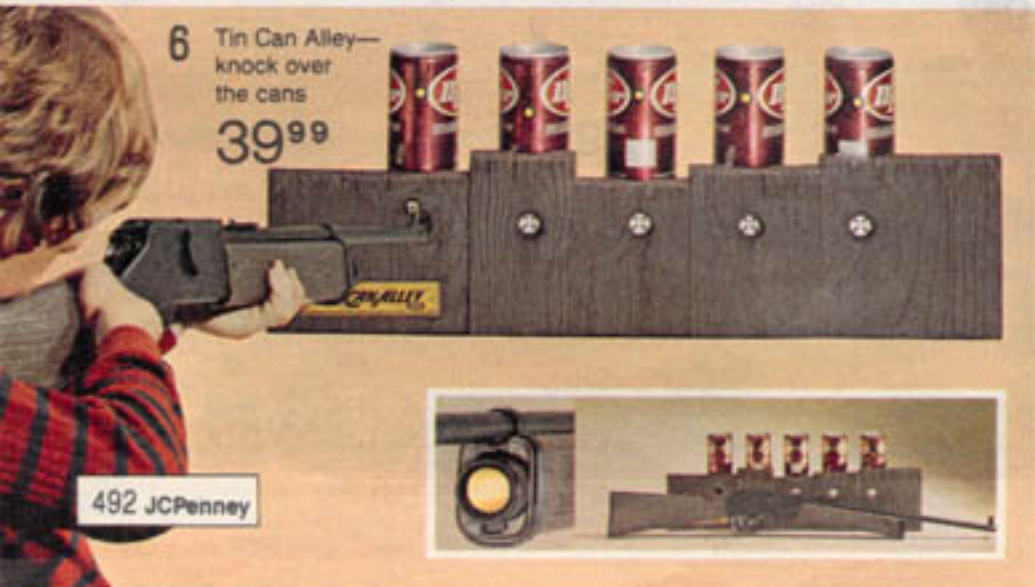

6 Tin Can Alley—knock over the cans
39⁹⁹



7 Stellar War—hear the hits explode
23⁹⁹



A

A 44-Level Chess Computer includes 2 built-in chess clocks. 16 levels of playing strength; 16 levels for fixed-time game; 8 teaching levels; 2 demonstration levels; 1 infinite level; 1 problem solving level. Selectable opening with more than 6,000 moves. User programmable library of over 240 moves. 4 different playing styles: normal, attacking, very aggressive, positional. Take-back feature—allows up to 120 half moves. Hint—assesses best move for opponent; verify position; game save...can replay whole game later; draw recognition; multi-move mode—checks validity of both players' moves. Many other features! About 14 x 2 1/4 x 18 1/2". Requires 4 'AA' batteries or universal adapter (both not incl.—batteries p. 398, adapter p. 395). 492 562 293—Each 219.99



B



F

B 16-Level Electronic Chess. Selectable book openings...approx. 300 positions. Position verification. Take-back—allows up to 4 half-moves; hint—assesses opponents best possible move. Checks legality of moves. Rejects illegal moves. Set-up/problem mode. About 13 1/2 x 2 1/2 x 14 1/4". Requires 4 'AA' batteries or universal adapter (both not included—batteries p. 398; adapter sold on page 395). 492 562 289—Each 149.99



C



G

C Sensory Electronic Chess with 8 levels of play. Verify position, take back, castling, en passant, pawn promotion. Abt. 11 x 13". Uses 4 'AA' batteries (not incl., see p. 398). 492 562 290—Each 99.99

D Limited Edition Chess Set. Weighted and felted. Deluxe inlaid wood chess board. Kings about 3 1/4" h. About 18 1/2 x 18 1/2 x 2". 492 562 282—Each 69.99



D



H

E Tapered Wood Chess Set. Pieces store inside felt-lined compartment. Inlaid playing field. Kings abt. 3" h. Open measures about 16 1/2" x 16 1/2". 492 562 044—Each 29.99

F Rummy Game with deluxe vinyl-covered attaché case; 106 tiles imprinted with card suits, 4 racks. About 15 x 8 x 2". 492 562 043—Each 29.99

G Quality Backgammon Set. 'High-tech' Grey vinyl case; Black velvet playing area. Attaché case about 10 1/4 x 2 1/4 x 7 1/2" closed. 492 562 004—Each 16.99



E

J

H Folding Cribbage Board...ideal for travel. Complete with deck of playing cards. Pegs store inside case when not in use. Plastic. About 1 1/2 x 6 1/4 x 3" when closed. 492 562 818—Each 5.49

J Plastic Automatic Card Shuffler can shuffle 1-2 decks with push-button operation. Cards not included. Uses 2 'C' batteries (not incl.—see p. 398). 492 562 118—Each 15.99

See our snow toys shown on pages 348-349



D

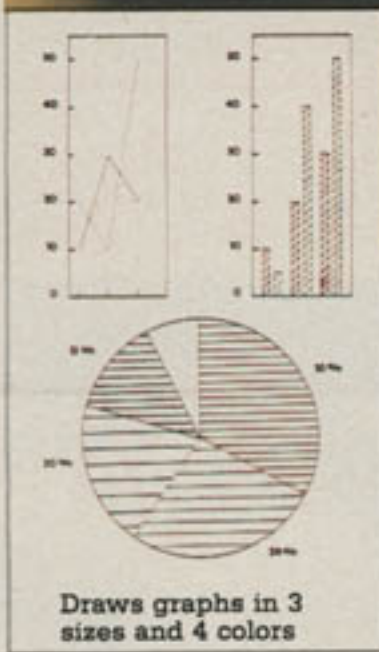

Draws graphs in 3 sizes and 4 colors

● 15-character LCD display

● Graph key—draws graphs with the touch of a key

● Color selector key and size selector key

● Built-in 4-function calculator

219.99 No money down
\$15 a month*

Brother® introduces the new Type-A-Graph Typewriter

D Brother® introduces state-of-the-art technology with the Type-A-Graph Ball Point Typewriter. It makes 8 types of graphs in 4 colors (black, green, blue and red) and 3 sizes. It integrates graphs and copy to make professional reports. Plus, it even types copy in 3 different sizes and 4 colors, horizontally and vertically with just the touch of a key. Even with all these features it only weighs 6 pounds and fits easily into a briefcase. Perfect for the student or business person. Has a built-in 4-function calculator. Professional keyboard. 15-character LCD display allows you to correct before print-

ing. Forward and reverse indexing, repeat key for all functions. Electronic tab and margin settings. Prints on any type of paper. Snap-on lid cover. Operates on 5 "D" cell batteries (not included) or AC adaptor (included). Manufacturer's Warranty.** (Replacement pens sold below.)

62 G 98292 MS—Ship. wt. 6 lbs. 219.99

Replacement pens for above. Package of four. Ship. wt. 1 oz.

62 G 98421—4 black pens. pkg. 4.99

62 G 98422—1 black, 1 red, 1 green, 1 blue . . . pkg. 4.99

Save \$70 **359.99** No money down
\$18 a month*

Correctronic 50 electronic typewriter doubles as a computer printer

E Correctronic 50, by Brother®, features full-line lift-off memory correction with automatic relocation after correction, interchangeable "cassette" type daisy wheel printing element (pica included) and triple pitch (10, 12 and 15 characters per inch) selector. 13½-in. carriage. Repeat typing for all keys. Vertical forward and reverse indexing. Express backspace. Decimal tabulation. Glare shield. International keyboard. Changeable type wheels in 5 styles: Script 1012, Quadro 15, Quadro 1012, OCR-B, Pica. Snap-on lid. Also, it's equipped with a built-in, pre-wired interface connector port for easy computer hook-up to produce paper copies of your programs. Requires interface module (F) and computer cables sold below. Mfr.'s Warranty.** Was 429.99 in our 1984 Fall Big Bk., pg. 708.

62 G 98332 MS—Ship. wt. 25 lbs. 359.99

F Interface module converts Executron 68 and Correctronic 50 into letter quality computer printer. Switch selectable between RS 232 serial and Centronics parallel. 2K memory. Requires cables below. NOTE: Typewriter/computer hook-up may require additional module provided by a computer store.

62 G 98339—Ship. wt. 2 lbs. 3 oz. 169.99

Cables to connect interface (F) to computer. Ship. wt. 8 oz. each.
62 G 98340—Atari 400, 800, 1200; 62 G 98343—IBM; 62 G 98344—Apple II; 62 G 98346—TRS 80 III and IV each 34.99
62 G 98435—For VIC 20, Commodore 64. Wt. 1 lb. 5 oz. . 89.99

Interchangeable "cassette" type daisy wheels for Executron 68 and Correctronic 50 typewriters. Ship. wt. 3 oz. each.
62 G 98334—Script; 62 G 98335—Quadro 1012; 62 G 98336—Quadro 15; 62 G 98338—ASCII (OCR-B) each 22.99

Ribbon and correction tape for (A), (B) and (E).
62G98293—Lift-off correction tape. Pkg. of 2. Wt. 2 oz. pkg. 5.99
62G98337—Black cassette ribbon. Wt. 3 oz. 5.99



E

F



7
Die-Cast
Metal
Body
500X
17⁹⁹



8
1000X
Projecting Microscope
Plus Mounting Kit
29⁹⁹



T.E.A.M.M.A.T.E. 12
create your own games . . . write
computer music, play electronic
games . . . and much more!
54⁹⁹

24 Prepared
Slides

4⁴⁹
Set

9



36 Prepared
Slides

7⁴⁹
Set



Over 500 pieces plus
two motors and
remote control

34⁹⁹

10



Mechanimals



11 The Everything Micro Lab—
Four Turrets that Zoom from
150X to 1200X. Projects,
plus Mounting Kit

64⁹⁹



13

Projecting
Microscope
from Tasco
that Takes
Pictures!

99⁹⁹



Drop-in
film cartridge

Program
Your Own
Electronic
Projects

100
Electronic
Projects
Kit

14

39⁹⁹



Deluxe
Electronic Kit

15

74⁹⁹

anywhere . . . in your room, on the bus, at the beach . . .

(11 and 12)
\$29.99



11

Head-to-head baseball and football tell you the play-by-play!

- Speech synthesizers narrate the action
- Play against the computer or a friend
- Large built-in LCD screens



12



13



14



Starting Lineup™ talking baseball gives you the pick of strategy and real players

15

11 and 12 It's like watching a real game! These fun talking games have a computer that simulates actual games and announces the play-by-play in an easy-to-understand electronic voice. Easy-to-use control buttons. Imported. Each requires 4 "AA" batteries sold on p. 406. Warranted by Tiger Electronics*. 1 or 2 players, ages 5 years and up.

11 You can pitch, swing, bunt, run, score and even return to your base with this fun-filled talking baseball game. Includes 3 levels of play. Sound on/off control and start button to begin the action. 49 N 64043—Wt. 1 lb . . . \$29.99

12 Control the moves on both offense and defense. Talking football lets you run, pass, punt, score and even kick the extra point. You also have to tackle or intercept on defense. Announcer gives down, yards to go, touchdowns and more! 2 levels of play. Sound on/off control and start button. 49 N 64042—Wt. 1 lb . . . \$29.99

*Write for free copy, see page 304.

13 TV Play-Along Wheel of Fortune™ game lets you play along with the television show as it happens! Place game in front of TV; the TV activates your game, displaying the puzzle on your game screen. You then race the TV contestants to guess the puzzle as they turn up letters, or use your game's keyboard to "spin for dollars" and guess letters on your own. Game also interacts with a show videotape, sold below, when the TV show is not on. Puzzle booklet helps you create your own puzzles. Uses one 9-volt battery sold on p. 406. Warranted by Mattel*. For 1 or more players, ages 8 years and up. 49 N 65025—Wt. 1 lb. 4 oz . . . \$79.99

TV Play-Along Wheel of Fortune™ video tape (not shown) interacts with TV Play-Along Wheel of Fortune game (13), sold above, when the TV show is not on. 15-minute tape contains 90 Wheel of Fortune puzzles. All categories are represented. VHS. For ages 8 years and up. 49 N 65031—Wt. 12 oz . . . \$19.99

14 Challenge your problem-solving abilities with the Shifty™ electronic puzzle. 24 puzzles of different difficulties; extra "scramble" puzzle offers a tougher challenge . . . just touch the LCD display and shift squares on the screen to solve each puzzle. Uses 2 "AA" batteries sold on p. 406. Imported. For 1 or more players, ages 8 years and up. 49 N 65012—Wt. 12 oz . . . \$29.99

15 Starting Lineup™ Talking Baseball not only gives you the sounds and excitement of a real ballpark, but it has the statistics of actual superstars built right into the game! You call the shots as manager and select the starting lineup. State-of-the-art electronic voice calls the play-by-play throughout the game. Includes baseball cards for each player with statistics shown on the back. Uses 4 "C" batteries sold on p. 406. Warranted by Parker Bros.® For 1 or 2 players, ages 10 years and up. 49 N 65045—Wt. 3 lbs. 1 oz . . . \$99.99

American League replacement cartridge contains statistics for 20 players from each team: Chicago, Kansas City, Minnesota and Texas. Includes reference cards for each player. 49 N 65046—Wt. 12 oz . . . \$29.99

National League replacement cartridge contains statistics for 20 players from each team: Chicago, Montreal and St. Louis. Includes reference cards for each player. 49 N 65049—Wt. 12 oz . . . \$29.99



A



B



C



D



E



F

Keep kids alert, busy, challenged!

A Tutor Play Computer™ by Tomy®—the perfect “first” computer. Has 12 different pictures that actually move; just push the space bar to animate the pictures. Gets read-outs while developing hand/eye coordination and improving perceptual skills. No batteries required. Ages: 3 to 7. 48 G 43707—Ship. wt. 1 lb. 2 oz. 14.99

B Ohio Art's Office Activity Center for young office executives. Dial typewriter really works; memo pad for important notes; rotary dial telephone at plug-in switchboard with intercom. There's even a click-click clock for clockwatchers! Stores neatly in carrying case. 48 G 43654—Ages: 3 to 9. Ship. wt. 5 lbs. 8 oz. 24.99

C Electronic Musical Phone from Playskool® has a 12-note keyboard. Boys and girls can play tunes from the color-coded song book or create their own songs. Uses one 9V battery (not included). Automatic on/off conserves battery life. Easy-to-hold pretend phone has flip-open cover. 48 G 43542—Ages: 3 to 8. Ship. wt. 10 oz. 9.99

D Tom Thumb Cash Register from Ohio Art teaches preschoolers money values as they play. 11 keys on steel housed register. Plastic base and drawer. Play paper money included. Ages: 3 and up. 48 G 43655—Ship. wt. 1 lb. 10 oz. 9.99

E-F Huggable, snuggable Snugglebumm's™ from Playskool. Hug them gently and they glow—perfect pals for little ones to take to bed. Each doll has a color-coordinated brush and 16-page full-color story booklet. About 6½ in. tall. Requires 2 “C” batteries (not included, order on page 490). Ages: 3 and up.

(E) Momma Brightly has pretty flower hair ribbon. 48 G 43702—Ship. wt. 1 lb. 2 oz. 9.99

(F) Papa Gently gives a warm, soft glow. 48 G 43703—Wt. 1 lb. 2 oz. 9.99

Most watches
\$2 to \$15 less
 thru December 15th

1 From ship to shore, you'll want this lightweight, navigator's quartz watch. Digital analog chronograph. Base metal case, adj. stainless steel band. Imported. Warranted by Nelsonic*.
 4 E 17047—Wt. 9 oz. . . Thru 12/15 \$24.99
 After 12/15 . . . \$39.99

2 SportMaster digital watch is water-resistant** to 50 meters. Includes 24-hour stopwatch countdown pacer to set stride and estimate distance; day, date, month and alarm. Black plastic case and band. Imported. Warranted by Innovative Time*.
 4 E 45486—Wt. 3 oz. . . Thru 12/15 \$19.99
 After 12/15 . . . \$24.99

3 For the true outdoorsman . . . this 30 meter water-resistant** watch has a compass on the strap. Alarm chronograph digital watch has time, month, day and date readout. Plastic case and strap. Imported. Warranted by Innovative Time*.
 4 E 16948—Wt. 3 oz. . . Thru 12/15 \$9.99
 After 12/15 . . . \$12.99

4 Piano watch has full musical scale. Video space game with missile launch and digital scorekeeper. 4-function calendar. Time readout with date, alarm, hourly chime and 24-hour military time. Silver-color plastic with stainless steel back and band. Imported. Warranted by Armitron®.
 4 E 45166—Wt. 5 oz. . . Thru 12/15 \$17.99
 After 12/15 . . . \$19.99



5 Memo Phone™ watch memorizes up to 42 individual ten-digit numbers for phone, credit cards, etc. 4-function calculator. Time readout includes month, day, date. Alarm and 24-hour military time. Silver-color plastic with stainless steel back and band. Imported. Warranted by Armitron®.
 4 E 45168—Wt. 5 oz. . . Thru 12/15 \$19.99
 After 12/15 . . . \$24.99

6 and 7 Alarm chronograph digital watches have 4-function calculators. Plastic case and plastic strap. Imported. Warranted by Innovative Time*.
 (6) 4 E 16942—Black Wt. 2 oz. . . \$5.99 (7) 4 E 16943—White Wt. 2 oz. . . \$5.99

8 "Ironman Triathlon" quartz digital alarm/chronograph watch has 3 separate timer operations. Displays time, month, day and date. Plastic case and plastic strap. Water resistant** to 100 meters. Warranted by Timex*.
 4 E 45660—Wt. 3 oz. . . Thru 12/15 \$34.95
 After 12/15 . . . \$39.95

9 At last, a digital watch for aerobic exercise! Pre-set countdown timer allows for easy pulse calculation. Water-resistant** with white plastic strap and Velcro® closure. Plastic case. Imported. Warranted by Timex*.
 4 E 45122—Wt. 3 oz. . . Thru 12/15 \$19.95
 After 12/15 . . . \$22.95

*Write for free copy, see p. 304.

10 Quartz watch is water-resistant** to 100 meters. Countdown timer, alarm chronograph, hourly chime. Time readout includes month, day, date. Black plastic with stainless steel back. Imported. Warranted by Casio*.
 4 E 45681—Wt. 4 oz. . . Thru 12/15 \$29.99
 After 12/15 . . . \$34.99

11 200 meter water-resistant** and shock resistant alarm chronograph digital watch. Plastic case, plastic strap. Imported. Warranted by Casio*.
 4 E 45743—Wt. 5 oz. . . Thru 12/15 \$54.99
 After 12/15 . . . \$64.99

12 6-digit stopwatch displays month, day and date on command. Records up to 1/100th second for 30 minutes and then 1 second increments up to 24 hours. Black plastic case with nylon cord. Imported. Warranted by Criterion*.
 4 E 19108—Wt. 3 oz. . . Thru 12/15 \$5.99
 After 12/15 . . . \$7.99

13 Heuer-look sport water-resistant** digital watch has three interchangeable plastic bands. Pop out plastic case. Imported. Warranted by Nelsonic*.
 4 E 45568—Wt. 3 oz. . . Price \$7.99

**WATER-RESISTANT NOTE: Water-resistant watches are designed to withstand water pressure of 35 pounds per square inch (in addition to normal atmospheric pressure) as long as crystal, back and button on digital watches remains intact.

YOUR CHOICE \$9.99

1. BLAST OFF FOR FUN WITH ROCKET LAUNCH. You're the pilot out to destroy enemy planes in this action game. When you hit an airborne plane, the screen lights up red to confirm and simulate the destruction. Includes powerful launch sounds and digital hit and miss counters. Imported. Requires 2 "AA" batteries, sold separately on page 459. For ages 3 years and up. 49 C 65007—Shipping weight 1 lb. 2 oz. . . \$9.99

2. THE DRIVING GAME PUTS YOU IN THE DRIVER'S SEAT. Test your driving skills as you race down a 2-lane course. You control the steering and braking, screen lights up red if you crash. Digital lap and crash counters. Imported. Requires 2 "AA" batteries, sold separately on page 459. For ages 3 years and up. 49 C 65001—Shipping weight 14 oz. . . \$9.99

3. "FOLLOW ME" GIVES YOUR MEMORY A WORKOUT. Try to repeat the same combination of flashing lights and sounds . . . but pay attention as each turn produces longer and faster sequences. 2 different games. Requires one 9-volt battery, sold separately on p. 459. Imported. Warranted by Sears, write for free copy, see p. 335. For 1 to 4 players. For ages 6 years and up. 49 C 65439—Shipping weight 8 oz. . . \$9.99

4. EXPERIENCE BIG LEAGUE ACTION WITH DIGITAL DIAMOND. This handy portable version of America's favorite pastime has all the action and variations of the real game. Scoreboard keeps score plus counts balls, strikes and outs. Imported. Requires 2 "AA" batteries, sold separately on page 459. For 2 players. For ages 6 years and up. 49 C 65446—Shipping weight 12 oz. . . \$9.99

5. "A GAME A DAY" KEEPS BOREDOM AWAY! This treasure chest of over 300 different games includes chess, checkers, Parcheesi, backgammon, bingo, baseball, dominoes and much, much more. Plus, everything is stored in a handy suitcase that's great for take-along fun. Also includes easy to follow instr. book. Games for 1 to 6 players. For ages 6 years to adult. 49 C 61190—Shipping weight 2 lbs. 8 oz. . . Set \$9.99

6. PRESTO CHANGO—YOU'RE A MAGICIAN WITH MAGIC-IN-A-HAT 'N TRICKS. Set consists of adjustable top hat, magic wand and props needed for 50 fascinating tricks. Easy to follow instruction book makes performing magic easy as pulling a rabbit out of a hat! For ages 6 years and up. 49 C 64051—Shipping weight 1 lb. 2 oz. . . Set \$9.99

7. BRING THE BIBLE TO LIFE WITH THE NOAH'S ARK AND TEN COMMANDMENTS GAMES. A deluxe version of the pre-school favorite, Noah's Ark features hand-painted plastic animals, 3-dimensional ark and pictorial spinner that makes reading or counting unnecessary. The Ten Commandments is a family game in which players help each other journey through the Bible lands of old to win. Noah's Ark game: for ages 3 years and up. Ten Commandments game: for ages 8 years and up. 49 C 61031—Shipping weight 3 lbs. 9 oz. . . Set \$9.99



There's more for your life at SEARS



Little Professor™ II
\$11.99



1 Learning can be fast and fun with the Little Professor™ II. Your child can sharpen math skills on 4 levels of play, with 2 chances to answer before correct answer is displayed. Correct answers get a smile from the professor and a star on the screen. Automatic shut-off after 2 minutes of non-use. Uses 2 "AA" batteries, sold sep. on p. 404. Warranted by Texas Instruments.*
For ages 5 years and up.
49 N 17604—Shipping weight 5 ounces... \$11.99

2 Talk 'N Teach™ is a teacher-on-tape that makes learning fun because it actually talks to children. Comes with 24 pre-recorded voice/workbook cards that ask questions about the alphabet, colors, shapes, animals and more, then, pauses to let children answer. Flip the cards over and there's a colorful exercise to reinforce the audio lesson. Each set also has 2 blank message cards so kids and parents can make their own messages. Warranted by Connor.* Requires 4 "D" batteries, sold separately on p. 404. For ages 3 years and up.
49 N 17775—Shipping weight 3 lbs. 8 oz... \$39.99

3 thru 8 Additional voice/workbook card packs include 24 voice cards plus 2 blank message cards.
(3) 49 N 17777—"Numbers." Wt. 8 oz... \$8.99
(4) 49 N 17778—"Shapes." Wt. 8 oz... \$8.99
(5) 49 N 17779—"Colors." Wt. 8 oz... \$8.99
(6) 49 N 17780—"Letters." Wt. 8 oz... \$8.99
(7) 49 N 17781—"Animals." Wt. 8 oz... \$8.99
(8) 49 N 17782—"Where Is It?" Wt. 8 oz... \$8.99

9 Thousands of arithmetic problems, 5 games and a lively little LCD man make the Math Master™ a joy. 3 levels of play keep it challenging. Requires 2 "AA" batteries, sold separately on page 404. For ages 4 to 12 years.
49 N 17601—Shipping weight 1 lb. 3 oz... \$19.99

10 The Spelling Master™ is a super way to develop and practice spelling skills. 150 words are stored in its memory bank to provide your child with 5 fun, educational games. Styled like a computer and has a membrane keyboard, LCD readout. Also incl. a comprehensive manual. Requires 2 "AA" batteries, sold separately on page 404. Was \$29.99 in our 1986 Toy Specialog, page 532. For ages 4 to 10 yrs.
49 N 17947—Shpg. wt. 1 lb. 1 oz... Now \$24.99

11 Dial-A-Teacher™ is a talking toy that helps prepare your child for early school years. By "dialing" up questions on the telephone dial, kids can learn the basics of spelling, math, music and more. Answers are punched in on the touch-pad keyboard. To change the subject, just remove one card and clip in another (5 two-sided cards included). Automatically shuts off after 2 minutes of non-use. Requires 4 "C" batteries, sold separately on p. 404. Additional programs available below. Warranted by VideoTech*. Was \$39.99 in our 1986 Toy Specialog, p. 533. For ages 3 to 6 years.
49 N 17901—Shpg. wt. 2 lbs. 12 oz... Now \$34.99

12 and 13 Additional programs for (11). Each includes a cartridge and 5 overlays.
For ages 3 to 6 years.
(12) 49 N 17902—Alphabet Fun
(13) 49 N 17903—Number Fun
Shipping weight 1 lb. 2 oz... Ea. \$12.99
*Write for free copy, see page 371.



Talk 'N Teach is a teacher-on-tape
\$39.99

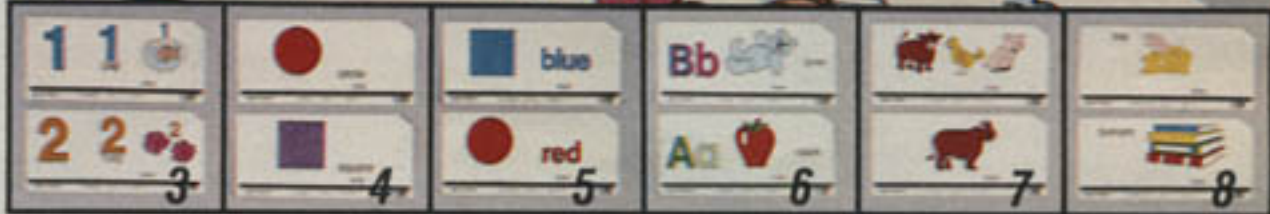

Math Master \$19.99



Spelling Master \$24.99



Dial-A-Teacher™ \$34.99



"Alphabet Fun" helps children identify words, letters and objects



"Numbers Fun" introduces your child to numbers in a delightful way

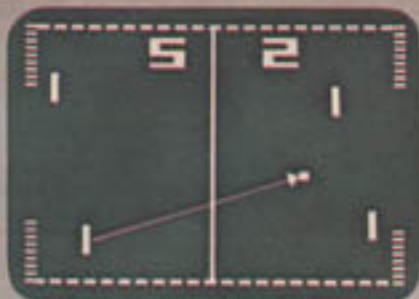

Hockey

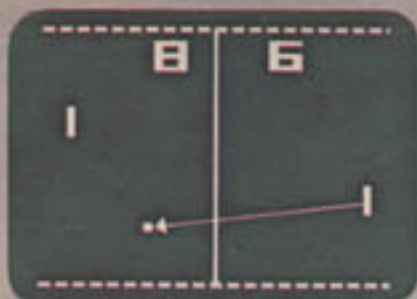

Tennis

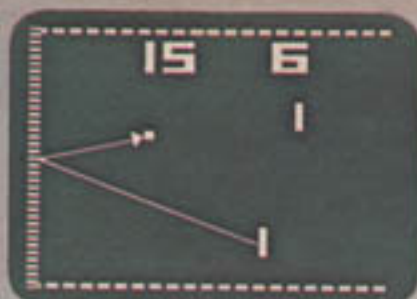

Handball

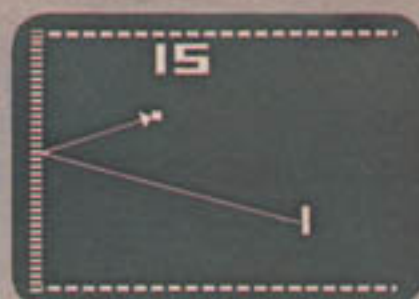

Solo Practice



This TV
not included—
sold in Fall
'76 Cat., p. 721

tv fun®—
the electronic
TV game that
never loses
its challenge



BECAUSE

- It's 4 games in 1
- Fits any size TV
- Has on-screen digital scoring
- Adjusts to ability of players

And priced at only

59⁸⁸

Now . . . the most excitement you've seen on TV in years. tv fun® is the family game that allows you to challenge each other in Hockey, Handball, and Tennis; or challenge yourself in tennis by playing Solo Practice. Two or four paddle operation. Ball speed, paddle size, and the angle of ball return can be changed to fit the ability and age of players. The degree of challenge can be altered so no one feels left out or loses interest. Court-layout on screen and paddles vary from game to game. The ball sounds every time it's hit. On-screen digital scoring.

It's simple to install with a screwdriver—takes just minutes, attaches to external VHF antenna leads on your TV. It's battery operated (six "C" cell batteries), or use optional DC converter (order both below). Complete instructions included. Once the game is attached, there is no need to disconnect it. Push lever to "Game", tune to a nonbroadcasting channel, turn on your TV set, and you're ready to play. For regular TV viewing, just push lever to "TV". When it's off, it will not interfere with normal TV viewing. Plastic housing; walnut-colored top with black sides. 18x9½x5½ in. deep. Mail. wt. 4.70 lbs.

X 917-1349 A 59.88

DC Converter. Converts 110-120 volts AC to DC. UL listed. Mailing weight 0.50 lb.

X 917-1158 A 6.95

Batteries. Package of six "C" cell batteries.

X 959-0787 A—Mail. wt. 0.60 lb. . . . Pkg. 1.39

See similar games in our Fall '76 Cat.—p. 788, and TVs in this cat. on p. 286. TV shown above sold in our Fall '76 Cat., p. 721.

New at Sears!



Kangaroo

4



Pole Position

7



Jungle Hunt

10

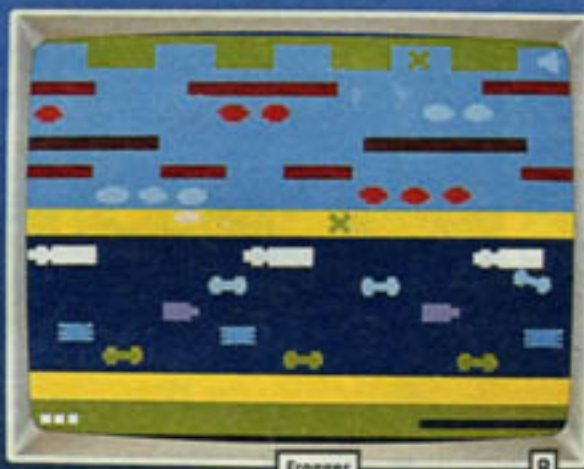

Frogger

8



Q*bert

11



Ms. Pac-Man

5



Space Dungeon

9



Dig Dug

6



Popeye

12

(4 thru 12) When necessary, cartridges include control-customizing keypad overlay for easy on-screen maneuvering. Convenient overlay storage slot in each cartridge case. Warranted by Atari; to write for free copy, see page 323. Shipping weight 8 ounces.

Cartridge name and description	Catalog Number	Price
(4) Kangaroo. Save Baby Roo by ducking, jumping and punching apple-throwing monkeys. 1 or 2 players.	49 C 75871	\$39.99
(5) Ms. Pac-Man. Guide this mobile mouth thru 2 different mazes, gobbling dots and floating fruit. 1 or 2 players.	49 C 75886	39.99
(6) Dig Dug*. Mine your own underground maze, burying your foes with boulders. 1 or 2 players.	49 C 75873	39.99
(7) Pole Position. Exciting speedway racing. 1 or 2 players.	49 C 75875	39.99
(8) Frogger. Four lanes of rush-hour traffic sure make this frantic frog jumpy. Guide him home safely. 1 or 2 players.	49 C 75955	39.99

Cartridge name and description	Catalog Number	Price
(9) Space Dungeon. All 99 floors of a treasure-laden space station are yours by beating aliens aboard. 1 or 2 players.	49 C 75876	\$39.99
(10) Jungle Hunt. Survive jungle perils to save sweetheart from savages' soup pot. 1 or 2 players.	49 C 75877	39.99
(11) Q*bert. Quickly bounce from cube to cube, quite avoiding a cast of queer characters out to drive you crazy! 1 or 2 players.	49 C 75956	39.99
(12) Popeye*. The sailorman gulps spinach to defeat Brutus and save Olive Oyl. 1 or 2 players.	49 C 75957	39.99
Joust*. Too new to show! Bird-riding gladiators duel on land or dogfight in the sky. 1 or 2 players.	49 C 75880	39.99

*Not available until Oct. 1, 1983

See more Atari 5200 cartridges on following page



FREE Cabbage Patch Doll with game A

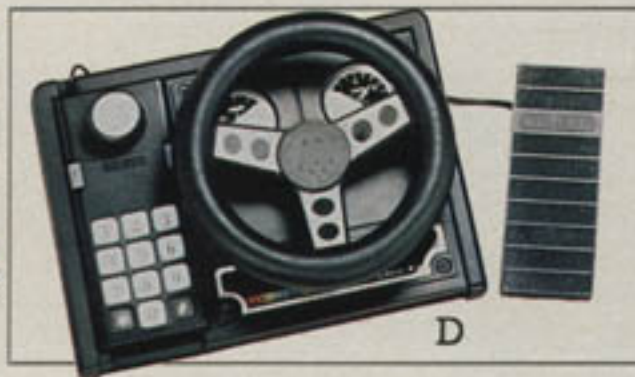

Receive a free Cabbage Patch Doll from Coleco when you buy a ColecoVision video game and cartridge

99.99

A That's right! Purchase a state-of-the-art ColecoVision game and a ColecoVision game cartridge by Coleco (sold below) and you'll adopt a Cabbage Patch Doll absolutely free! Just follow the details on the mail-in offer when your game and cartridge arrive. Offer good through December 31, 1984. ColecoVision video game includes Donkey Kong cartridge, two 8-directional

joysticks with keyboards and 2 fire/action buttons. Operates on any color or black and white television. Will not interfere with TV reception. Turn to page 521 and see how ColecoVision converts into the ADAM Family Computer System. Manufacturer's Warranty.* 67 G 95000 D—Ship. wt. 7 lbs. 99.99

ColecoVision accessories priced for your Christmas gift-giving

79.99

B This module allows ColecoVision to accept cartridges from other manufacturers. Enjoy the entire library of existing and future game cartridges that are made for and compatible with the Atari 2600 Video Computer System. Just slide the expansion module into the expansion port on the ColecoVision console, insert Atari game cartridge and you're ready to play! Manufacturer's Warranty.* 67 G 95002—Ship. wt. 2 lbs. 8 oz. 79.99

D Turn your ColecoVision into the cockpit of a high-performance race car and get realistic sports action. Tabletop console includes a large arcade-style steering wheel and accelerator pedal that operates from the floor. Regular controller mounts in the driving console and becomes the gear shift. Accelerator pedal stores in console when not in use. Module also includes Turbo™ game cartridge, a fast-paced 3-D racing game. Manufacturer's Warranty.* 67 G 95003—Ship. wt. 2 lbs. 8 oz. 79.99

C ColecoVision's super action controllers make sports and action games even more fun. 8-direction control sticks for full field movement. Speed roller lets you increase or decrease the tempo of the game. Multiple use player/select buttons and keypads for even more precise game control. Includes Super Action Baseball cartridge. Manufacturer's Warranty.* 67 G 94136—Ship. wt. 1 lb. 79.99

E ColecoVision roller controller gives you high-speed action. Spin it for lightning-fast 360 degree on-screen motion. Includes bonus Slither™ game cartridge. Makes your home game play like a real arcade. Manufacturer's Warranty.* 67 G 94137—Ship. wt. 1 lb. 79.99

Replacement controllers for ColecoVision game (A). 67 G 95001—Ship. wt. 1 lb. 24.99

Order exciting ColecoVision video software below. See how ColecoVision turns into the ADAM computer on page 521.

Save 11% to 29% on ColecoVision software when you buy 2, 3 or more cartridges

Game cartridges for ColecoVision

Title*	Players	Catalog number	Ship. wt.	Price each	Any 2, each	3 or more, each
Games by Coleco for ColecoVision						
Space Fury	1 or 2	62 G 43600 D	9 oz.	21.99	18.99	16.99
Venture	1 or 2	62 G 43601 D	9 oz.	14.99	13.49	11.99
Victory	1 or 2	62 G 43602 D	9 oz.	21.99	18.99	16.99
Mouse Trap	1 or 2	62 G 43603 D	9 oz.	14.99	13.49	11.99
Space Panic	1 or 2	62 G 43604 D	9 oz.	14.99	13.49	11.99
Rocky†	1 or 2	62 G 43607 D	9 oz.	21.99	18.99	16.99
Lady Bug	1 or 2	62 G 43608 D	9 oz.	21.99	18.99	16.99
Cosmic Avenger	1 or 2	62 G 43609 D	9 oz.	21.99	18.99	16.99
Black Jack	1 to 4	62 G 43613 D	9 oz.	21.99	18.99	16.99
Smurf Rescue	1 or 2	62 G 43616 D	9 oz.	14.99	13.49	11.99
Carnival	1 or 2	62 G 43618 D	9 oz.	14.99	13.49	11.99
Mr. Do	1 or 2	62 G 43619 D	9 oz.	21.99	18.99	16.99
Donkey Kong Jr.	1 or 2	62 G 43620 D	9 oz.	21.99	18.99	16.99
Time Pilot	1 or 2	62 G 43622 D	9 oz.	21.99	18.99	16.99
Omega Race	1 or 2	62 G 43623 D	9 oz.	21.99	18.99	16.99
Front Line	1 or 2	62 G 43624 D	9 oz.	21.99	18.99	16.99
Sub Roc	1 or 2	62 G 43627 D	9 oz.	21.99	18.99	16.99
Gorf	1 or 2	62 G 43630 D	9 oz.	21.99	18.99	16.99
Pepper II	1 or 2	62 G 43632 D	9 oz.	21.99	18.99	16.99
Looping	1 or 2	62 G 43631 D	9 oz.	21.99	18.99	16.99
Zaxxon	1 or 2	62 G 49515 D	9 oz.	21.99	18.99	16.99
Games by Parker Brothers for ColecoVision						
Frogger	1	62 G 46625 D	9 oz.	34.99	29.99	27.99
O*bert	1	62 G 46626 D	9 oz.	34.99	29.99	27.99
Popeye	1	62 G 46627 D	9 oz.	34.99	29.99	27.99



Zaxxon

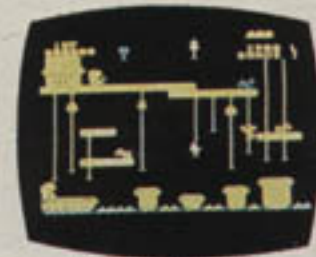

Donkey Kong Jr.

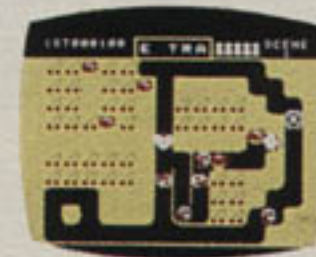

Mr. Do

†For use with Super Action Controllers (C).

*Write for a free copy of Manufacturer's Warranty, see page 497.

You'd better be quick, or your opponent will **PUNCH YOUR LIGHTS OUT!**



It's not just another action game,
it's a Sears Land sensation!

\$29⁹⁹

A New Sears Land Exclusive! *Punch Your Lights Out* is sure to challenge your agility. It's the ultimate game to test your speed, reflexes and skill in trying to punch out all twelve of the lights on your number key. In each of 3 games, the moving display randomly selects a number from 1 to 12 and you have to "punch out" (turn off) as many lights as possible. Use any combination of numbers to get the right one (for example, $6+4+2=12$) . . . all in a matter of seconds. See descriptions of each game below. High-impact plastic body. Uses 4 "C" batteries sold on page 406. Warranted by manufacturer; write for free copy, see page 304. For 1 or 2 players, ages 5 years and up. 49 N 64041—Weight 1 pound 12 ounces . . . \$29.99



PUNCH OUT gives you 30 seconds per round to try to "punch out" as many of the numbers that light up as you can.

LIGHTS OUT has no time limit, but to win, you must punch out all the lights on your display as soon as they appear.

TIME OUT gives players 30 seconds per round to be the first one to punch out your lights and earn more points.



Sears exclusive Light Optic Screen makes this TV's picture more visible in full sunshine than any we've ever offered

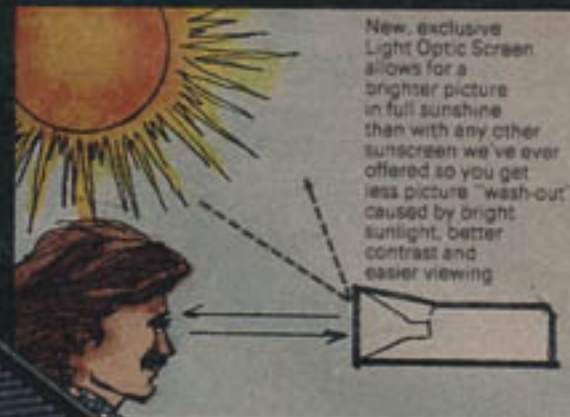

New, exclusive Light Optic Screen allows for a brighter picture in full sunshine than with any other sunscreen we've ever offered so you get less picture "wash-out" caused by bright sunlight, better contrast and easier viewing

Sears *Best

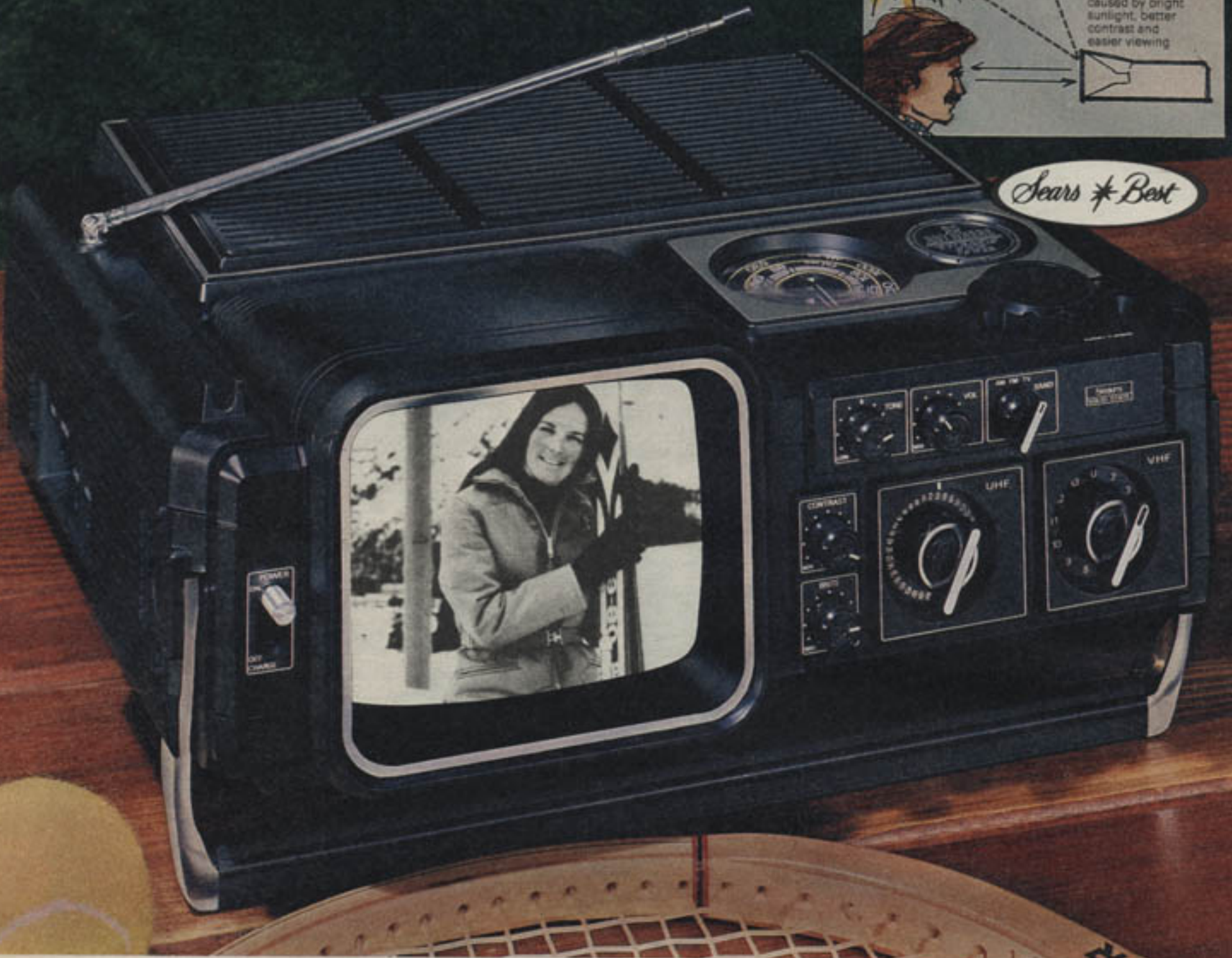

Go Anywhere™ AC/DC Black and White Portable TV with 5-inch diagonal measure picture screen and built-in AM/FM radio

\$164⁹⁵ without batteries

Goes anywhere you go because this light, compact portable TV with AM/FM radio weighs just 12 lbs. Take it with you to the beach, on a picnic, to the football game. Detachable Light Optic Screen filters out sunlight far better than conventional sunscreens so you get a more visible picture in bright sunlight than with any other set we've ever offered.

PICTURE TUBE, TUNING CONTROLS: 13-sq. in. picture. Front-mounted, click-in YHF and UHF channel dials. Front-mounted controls for volume, tone, contrast and brightness.

CABINET, CONSTR: Molded plastic cabinet, 13⁷/₁₆x4¹³/₁₆x14³/₁₆ in. deep. Detachable sunscreen with abrasion-resistant coating. 3x5-in. oval speaker. Carrying handle can be used as stand to prop up TV. Earphone.

RADIO: AM/FM radio with front-mounted TV/AM/FM selector. Top-mounted rotary tuning dial and indicator. Built in AM and telescoping swivel FM/VHF/UHF antenna.

ELEC. INFO: AC or DC powered. UL listed. Runs on 120-v., 60-Hz. AC with 6-ft. cord, 12-v. negative ground DC automotive system with vehicle cigarette lighter adapter and 10-foot cord (included), 9 optional D-size batteries (order on page 414) or rechargeable battery pack (2) sold below. Recharger case (1) sold below is also required to recharge TV. Draws 13 w. AC or 7.5 w. DC.

ORDERING INFORMATION: See warranty on next page and "N" suffix note on page 322. 57 C 50382N—Shipping weight 13 pounds \$164.95

(1) Plastic Recharger Case. Required for recharging battery pack (2). 57 C 5067—Shipping weight 1 pound \$4.95

(2) Rechargeable Battery Pack for TV above. Rechargeable 400 times. Lead-acid battery. Fits inside TV with case (1) above, provides about 5 hours TV playing time, 25 hours on radio alone. With case (1) sold separately above, battery pack will recharge automatically when set is off and plugged into AC outlet. 57 C 5066—Shipping weight 5 pounds \$24.95

(3) Carrying Case for TV above. Embossed leather-look vinyl. Detachable shoulder strap with adj. buckle, slide-on mini pouch for carrying cords. TV handle doubles as case handle. No need to remove case to watch TV . . . unzip zippers, fold back flaps, TV ready for watching. Speaker holes. Opening for earphone. 57 C 5078—Shpg. wt. 3 lbs. \$14.95

SIMULATED RECEPTION ON ALL TVS

Runs on any of 4 power sources: AC house current, DC current with vehicle cigarette lighter adapter, 9 optional "D" batteries or rechargeable battery pack and case sold separately below.



408 Sears ALL

For little musicians...
it's showtime!

A Rhythmic 6™ ...portable electronic keyboard. Powerful stereophonic output. Built-in outlet for external amp. 49 keys. Built-in speakers. Reproduces the exact tones of 10 of the most popular instruments. 10 built-in rhythms. Uses 6 'C' batteries (not included—see p. 398) or AC adapter (not incl.—see p. 395).
492 532 072 DL—Ages 4 years and up. Each . . . 189.99



A

B Rhythmic 2™ ...portable electronic keyboard with built-in speaker. Reproduces 10 of the most popular instruments. 10 built-in rhythms. 49 keys. Ages 4 years and up. Needs 6 'C' batteries (not incl.—see p. 398) or AC adapter (not incl.—see p. 395).

492 532 011 DL—Each 139.99

C Electric Table Top Organ. 25 keys, 6 chords. Song book included. Plastic. About 21 x 8¼ x 3¾" high. Ages 4 and up.

492 532 109 DL—110-volt. Each 59.99



B

C



H

D Computer Organ for learn and play fun. Vibration and volume control. 8 pre-programmed songs. Recording and playback features. Ages 4 and up. Needs 6 'AA' batteries (not incl.—see p. 398).
492 532 104 D—Each 49.99



D

G SAVE 10.00 on children's stage microphone. Adjusts from 2-4' high. On/off volume control on amplifier with large, full-sound speaker. 8' removable cord. 9-volt battery included. For ages 5 years and up. Sears reg. 49.99.

492 532 138 DL—Each 39.99



G

SAVE \$10

H Deluxe Electric 'Reed' Organ has 37 Black and White melody keys plus 12 chord buttons (6 major, 6 minor). Easy-to-read chord and number selector strip. Legs detach. High-impact plastic. 110-volt. Instructions, music rack, songbook incl. Abt. 34¼ x 11¼ x 30½" h.

492 532 023 DL—Bench not incl. Ages 4 and up. Each 119.99

J 'Boss' Guitar. 3 nylon strings, 3 metal-wound nylon strings. Friction tuning pegs. Plastic. Ages 4 years and up.

492 532 027 DL—Each 15.99

K 'Boss' America Drum Set. Pro-style set in 'textured' Red steel. Bass drum about 20" high x 9" wide; snare drum, 6" bongo drum, 9" hissing cymbal, 9" regular cymbal, pair of drumsticks, sound block, bell and foot beater. Ages 4 years and up.

492 532 060 DL—Each 59.99



K

J



E

F

SAVE \$3

E 29" Wooden Guitar. 6 metal strings. Geared machine-head tuning. Suitable for ages 5 years and up.
492 532 019 DL—Each 31.99

F SAVE 3.00 on this 21" wooden guitar. 6 metal strings. Ages 5 years and up. Sears reg. 14.99.
492 532 094 DL—Each 11.99

For our largest selection of games see pages 360 to 367



Whiz-Kid™
video learning toy
\$49.99



6

1 The Whiz-Kid™ simulates home-computer excitement. Uses colorful graphics and a clear LCD readout to teach a variety of subjects. Through games and gentle musical encouragement, your child is exercised in math, spelling, music, general knowledge and much more. Includes a built-in cartridge and 50 "input" cards to start. Additional learning programs are available below. Keyboard folds in and includes a shoulder strap, making the Whiz-Kid a snap to take anywhere. Requires 4 "C" batteries, sold on page 404. For ages 6 to 10 years. Warranted.* 49 N 17739—Shpg. wt. 2 lbs. 5 oz. . . \$49.99

2 thru 5 Additional learning programs for (1). Include a cartridge and 50 "input" cards. For ages 6 to 10 years.
(2) 49 N 17742—Alpha Fun
(3) 49 N 17743—Word Fun
(4) 49 N 17744—Cross Word
(5) 49 N 17746—Number Fun
Shipping weight 8 ounces. . . Each \$12.99

6 Whiz-kid card and cartridge case helps organize Whiz-Kid additional learning programs (2 thru 5). Holds up to 200 cards and 4 cartridges. 49 N 17738—Shipping weight 1 lb. . . \$5.99

7 The perfect way to introduce children to basic programming . . . the Laser™ 50 is a go-anywhere personal computer! So lightweight it fits in your bookbag. With an incredible matrix LCD screen, this little dynamo even handles trigonometry. 46 keys, most with multi-functions. Automatic shutoff. Requires 4 "AA" batteries, sold separately on page 404. Instructions included. Warranted by VideoTech*. For ages 6 years and up. 49 N 17877—Shpg. wt. 2 lbs. 4 oz. . . \$69.99

The Laser™ 50
portable
personal
computer
for kids
\$69.99



7

8 Type-right™, the interactive typing-tutor, actually helps teach touch typing . . . for computer or typewriter keyboards. 9 courses and a game to make learning fun, plus it's interactive—monitors students' progress and grades speed and accuracy. Requires 4 "C" batteries, sold separately on page 404. Warranted by VideoTech*. For ages 9 years and up. 49 N 17909—Shpg. wt. 1 lb. 12 oz. . . \$39.99

9 A world of discovery awaits through the Learning-Window™. This premium, interactive teaching machine features animation, a matrix dot screen and 13 lively activities. Includes lessons in math, counting, spelling, logic . . . even drawing, music and puzzles. Requires 6 "C" batteries, sold separately on page 404, or uses AC adapter sold on facing page. Voice cartridge and additional program cartridges, sold separately below. Warranted by VideoTech*. For ages 6 years and up. 49 N 17937—Shpg. wt. 3 lbs. 11 oz. . . \$54.99

10 thru 12 Additional program cartridges for (9). Cartridges (10) and (11) have 5 activities. (12) has 3 activities, animation and 50 new words.
(10) 49N17939—Number power. Ages 8 yrs. and up
(11) 49N17940—I.Q. Builder. Ages 6 yrs. and up
(12) 49N17941—Alphabet Soup. Ages 7 yrs. and up
Shipping weight 2 oz. . . Each \$12.99

13 Voice cartridge for (9) above, adds a friendly computer voice to the fun. Interacts with all additional programs (10 thru 12), too. Ages 6 years and up. 49 N 17938—Shpg. wt. 2 oz. . . \$19.99
*Write for free copy. See page 371.



Learn to type with
Type-right™
\$39.99

8



The Learning-Window™ \$54.99



10

11

12

15-character LCD enables you to correct and edit from memory

Repeat typing for all keys and functions

Variable 10, 12, 15 and proportional space typing

 Changeable type wheel in 5 styles:
Script 1012, Quadro 15,
Quadro 1012, OCR-B, Pica

A



Save \$70

499.99 No money down
\$25 a month*

Executron 68... Brother's® newest advanced electronic typewriter

A Finally, an affordable compact electronic office typewriter with some of the most unique features you'll ever find on a typewriter in its price range! 5,000-character memory for text and phrase storage. The text memory is used for editing copy and the phrase memory can be used to store often-used names, addresses and short phrases. 15-character liquid crystal display enables you to correct and edit from memory. Variable 10, 12, 15 and proportional spacing, right margin justification that perfectly aligns the right hand margin, automatic centering, automatic return, automatic underlining and bold print capability.

Executron 68 also includes one-line memory for automatic lift-off correction, as well as automatic relocation key, decimal tabulation, repeat typing for all keys, one-touch interchangeable "cassette" type daisy wheel and auto paper feed.

Add the optional interface module (on opposite page) and it also becomes a letter-quality printer for your home or personal computer. Also has bi-directional printing from memory. Manufacturer's Warranty.** Was 569.99 in our 1984 Fall Big Book, page 708. Buy ribbons and correction tape on opposite page.

62 G 98394 MS—Ship. wt. 27 lbs. now 499.99

B



249.99 No money down
\$15 a month*

Brother® electronic typewriter

B Brother® Student-Riter XLI . . . the perfect gift for anyone in high school, college or graduate school. One-touch interchangeable "cassette" type daisy wheel. Cassette ribbon pops in and out for tangle-free, mess-free ribbon changes. Tabulator—one touch for tab, set or clear. Repeat typing for all keys. Automatic relocation. 20-character memory for automatic lift-off correction. Variable 10 and 12-pitch typing. Variable 1, 1½, and 2-line spacing. Standard office keyboard.

Built-in handle and lid cover makes this typewriter portable. Manufacturer's Warranty.** Buy ribbons and correction tape on opposite page.

62 G 98391 MS—Ship. wt. 16 lbs. 249.99

*Montgomery Ward Credit customers: This purchase may change your monthly payments depending on the highest balance on your account. Does not apply to AZ, NM and OR residents. See page 497.

**Write for a free copy of Manufacturer's Warranty, see page 497.

Save \$70

299.99 No money down
\$17 a month*

Silver Reed multi-print electronic typewriter

C It's capable of printing on both thermal and normal paper; it offers a large range of characters and symbols (180) without the bother of changing printing elements. Has letter-quality dot-matrix print. Cassette ribbon for mess-free ribbon changes.

In addition to the standard keyboard front and Print Pitch Selector (10 pitch for pica, 12 pitch for elite), there is a Print Pattern Selector. It allows you to choose any of the following 6 print patterns: normal, bold, double bold, enlarged, automatic underline and shadow. Plus, the Correction Print feature lets you correct errors in any style before they're printed on paper. Even has a built-in port to connect to interface module (sold at right) and allow EXD 15 to become a letter-quality computer printer. Interface module connects to your home or

C



personal computer. Some computers may require an additional interface or cable at the computer. Manufacturer's Warranty.** Was 369.99 in our 1984 Fall Big Book, page 709.

62 G 98301 MS—Ship. wt. 16 lbs. . . 299.99

Computer interface module for 98301 above. For RS232C serial. For use with Commodore 64, VIC 20.

62 G 98311—Ship. wt. 2 lbs. 129.99

For Centronics parallel. For use with Atari 400/800, TRS-80 III and IV, Apple II, IBM PC.

62 G 98312—Ship. wt. 2 lbs. 129.99

Ribbon for Silver Reed 98301. Pkg. of 2.

62 G 98302—Ship. wt. 4 oz. pkg. 7.99

Save \$50 to \$60 over separate prices when you buy computer (A), disk drive (B) and memory module (C)

You can also Save \$25 to \$102 when you buy other computer and peripheral combinations on pp. 1098-1100 in 1985 Fall Big Book



A thru C. For advanced personal productivity and business programs, buy this C128 computer system for \$25 monthly*. Computer (A) has 128K RAM memory to store up to 80 double-spaced typed pages, and is expandable to 256 or 512 K with modules sold below. Works in 64, 128 or CP/M modes. Built-in Microsoft® PET BASIC language. 16-color selection, 92-character keyboard. Works with monitors with 40 or 80-column displays. 100% compatible with all C64 software and peripherals. The C1571 disk drive (B), when used with the C128, runs faster data transfers than (C) on opp. page. Loads an average program in 4 seconds to save you time. Stores up to 350K or 220 double-spaced typed pages on 5¼-in. floppy disk (not incl.). The C128 RAM expansion cartridge (C) plugs into C128 computer to provide up to 256K of memory for data or program storage. Works in all modes. Warranted by Commodore**.

3 E 32203C—Sep. prices total \$749.97. Shpg. wt. 18 lbs. . . System (A, B, C) **\$699.97**

Above system, but with expansion cartridge that provides up to 512K of memory.

3 E 32202C—Sep. prices total \$949.97. Shpg. wt. 18 lbs. . . System **\$889.97**

A. C128 Computer alone. \$13 monthly*.
3 E 32110—Shpg. wt. 6 lbs. 6 oz. . . **\$299.99**

C. 256K RAM expansion cartridge alone.
3 E 32602—Shipping weight 1 pound. . . **\$149.99**

B. C1571 Disk drive alone. \$13 monthly*.
3 E 32304—Shipping weight 11 pounds. . . **\$299.99**

512K RAM expansion cartridge (not shown) alone.
3 E 32604—Shipping weight 1 pound. . . **\$349.99**

D. Color composite video monitor for \$10 monthly* has 13-in. diag. measure picture, 40-column readability, 1000 characters viewable at one time. Separate video, audio outputs, 1-watt speaker. Cable included connects to C64, Plus/4, C128 and Atari 400, 800, 800XL computers. Imported. Warranted by Sears**. 3 E 20424C—Shipping weight 29 pounds. . . **\$199.99**

80-column RGB monitor (57 E 4084C) also available, sold on p. 600.

E. Commodore mouse creates pictures, moves words or pictures on screen. Great for alternate keyboard entry. 3 E 32550—Shipping weight 1 pound. . . **\$49.99**

Home/office CPM based software programs (not shown) for the C128 computer sold above. All are diskette format programs and use disk drive. Warranted by Commodore**. All Perfect™ programs are fully integrated.

Title	Description	Catalog No.	Shpg. wt.	Price
Jane™	Easy-to-use program for word processing, spreadsheet or filing needs.	T 3 E 20350	13 oz.	\$49.99
Perfect Calc™	Sophisticated spreadsheet handles financial, statistical analyses.	T 3 E 20351	13 oz.	69.99
Perfect Filer™	Improve your data management with your files at your fingertips.	T 3 E 20352	13 oz.	69.99
Perfect Writer™	Professional word processing package with editing programs.	T 3 E 20353	13 oz.	69.99

F and G. Solid oak computer furniture with oak-veneer finish. Rear slots for cords. Unassembled; instr. incl.

F. Computer desk for \$11 monthly* has convenient storage compartment with door. Adjustable floor glides help protect floor. 44Wx28Hx27D in. 3 E 61252C—Shipping weight 60 pounds. . . **\$219.99**

G. Hutch fastens to (F) for vertical storage. 3 adjustable shelves. 44Wx34Hx14D in. 3 E 61253C—Shipping weight 45 pounds. . . **\$169.99**

Save \$100 when you buy both (F) and (G). Sep. prices total \$389.98.

3 E 61257N—Shipping weight 105 lbs. . . Set **\$289.98**

*See p. 338. **Write for free copy, see p. 335.

Items with "T" prefix could take extra time for delivery

H. Computer stand of particle board. Adjustable floor glides. 39Wx37Hx23D in. Unassem. 3 E 61227N—Oak-grained (shown) 3 E 61226N—Walnut-grained Shpg. wt. 83 lbs. . . **\$89.99**

IMPORTANT PRICE NOTICE: Due to changing market conditions, prices of computers, peripherals and software may be lower than figures printed in this catalog. Call your nearest Sears catalog selling unit for current prices.



Save 5% to 20% on Atari 2600 software when you buy 2, 3 or more cartridges over \$5

Game cartridges for Atari 2600

Title*	Players	Catalog number	Ship. wt.	Price each	Any 2, each	Any 3 or more, each
Games by Atari for Atari 2600 console						
Pole Position	1	62 G 43288 D	6 oz.	29.99	26.99	23.99
Centipede	1 or 2	62 G 43298 D	6 oz.	29.99	26.99	23.99
Dig Dug	1 or 2	62 G 43301 D	6 oz.	29.99	26.99	23.99
Kangaroo	1 or 2	62 G 43314 D	6 oz.	29.99	26.99	23.99
Mario Brothers	1 or 2	62 G 43319 D	6 oz.	29.99	26.99	23.99
Ms. Pac Man	1 or 2	62 G 49524 D	6 oz.	24.99	22.99	19.99
Jungle Hunt	1 or 2	62 G 43313 D	6 oz.	24.99	22.99	19.99
Berzerk	1	62 G 43274	6 oz.	4.99	—	—
Warlords	1	62 G 43276	6 oz.	4.99	—	—
Sword Quest—Earth World	1	62 G 43295	6 oz.	4.99	—	—
Sword Quest—Fire World	1	62 G 43296	6 oz.	4.99	—	—
Air/Sea Battle	1 or 2	62 G 43218	6 oz.	4.99	—	—
Raiders of the Lost Ark	1 or 2	62 G 43311	6 oz.	4.99	—	—
Yar's Revenge	1 or 2	62 G 43275	6 oz.	4.99	—	—
Breakout	1 to 4	62 G 43325	6 oz.	4.99	—	—
E.T.	1 or 2	62 G 43312	6 oz.	4.99	—	—
Circus Atari	1 or 2	62 G 43250	6 oz.	4.99	—	—
Video Pinball	1 or 2	62 G 43278	6 oz.	4.99	—	—
Haunted House	1 or 2	62 G 43253	6 oz.	4.99	—	—
Demons to Diamonds	1 or 2	62 G 43251	6 oz.	4.99	—	—
Adventure	1 or 2	62 G 43271	6 oz.	4.99	—	—
Football	1 or 2	62 G 49521	6 oz.	4.99	—	—
Vanguard	1 or 2	62 G 43284	6 oz.	4.99	—	—
Galaxian	1 or 2	62 G 43283	6 oz.	4.99	—	—
Phoenix	1 or 2	62 G 43289	6 oz.	4.99	—	—
Games by ActiVision for Atari 2600 console						
Pitfall	1	62 G 49528 D	6 oz.	29.99	26.99	23.99
Chopper Command	1 or 2	62 G 42841 D	6 oz.	24.99	22.99	19.99
River Raid	1 or 2	62 G 42843 D	6 oz.	24.99	22.99	19.99
Sea Quest	1 or 2	62 G 42844 D	6 oz.	24.99	22.99	19.99
Keystone Kapers	1	62 G 42845 D	6 oz.	24.99	22.99	19.99
Dolphin	1 or 2	62 G 42847 D	6 oz.	24.99	22.99	19.99
Enduro	1	62 G 42848 D	6 oz.	24.99	22.99	19.99
Decathlon	1 or 2	62 G 42851 D	6 oz.	24.99	22.99	19.99
Spider Fighter	1	62 G 42852 D	6 oz.	24.99	22.99	19.99
Freeway	1 or 2	62 G 49527 D	6 oz.	19.99	17.99	15.99
Grand Prix	1	62 G 42836 D	6 oz.	9.99	8.99	7.99
Barnstorming	1	62 G 42837 D	6 oz.	9.99	8.99	7.99
Boxing	1 or 2	62 G 42820	6 oz.	4.99	—	—
Skiing	1	62 G 42823	6 oz.	4.99	—	—
Games by Coleco for Atari 2600 console						
Donkey Kong	1	62 G 49547 D	6 oz.	14.99	12.99	11.45
Zaxxon	1	62 G 43800 D	6 oz.	14.99	12.99	11.45
Smurf Action	1	62 G 43802 D	6 oz.	14.99	12.99	11.45
Mouse Trap	1 or 2	62 G 43804 D	6 oz.	14.99	12.99	11.45
Donkey Kong Jr.	1	62 G 43808 D	6 oz.	14.99	12.99	11.45
Mr. Do	1	62 G 43810 D	6 oz.	14.99	12.99	11.45
Venture	1	62 G 43803 D	6 oz.	9.99	8.99	7.99
Games by Imagic for Atari 2600 console						
Dragon Fire	1 or 2	62 G 45215 D	6 oz.	9.99	8.99	7.99
Fathom	1	62 G 45219 D	6 oz.	9.99	8.99	7.99
Moon Sweeper	1 or 2	62 G 45220 D	6 oz.	9.99	8.99	7.99
Solar Storm	1 or 2	62 G 45223 D	6 oz.	9.99	8.99	7.99
Quick Step	1 or 2	62 G 45225 D	6 oz.	9.99	8.99	7.99
Star Voyager	1 or 2	62 G 45211 D	6 oz.	9.99	8.99	7.99
Demon Attack	1 or 2	62 G 49549 D	6 oz.	9.99	8.99	7.99
Atlantis	1 or 2	62 G 45212 D	6 oz.	9.99	8.99	7.99
Riddle of the Sphinx	1	62 G 45214 D	6 oz.	9.99	8.99	7.99
Trick Shot	1 or 2	62 G 45948	6 oz.	4.99	—	—
Fire Fighter	1	62 G 45200	6 oz.	4.99	—	—
Games by Parker Bros. for Atari 2600 console						
Frogger	1 or 2	62 G 49511 D	6 oz.	29.99	26.99	23.99
Q*bert	1 or 2	62 G 46510 D	6 oz.	29.99	26.99	23.99
Reactor	1 or 2	62 G 46403 D	6 oz.	24.99	22.99	19.99
Star Wars	1 or 2	62 G 46400 D	6 oz.	9.99	8.99	7.99
Star Wars—Jedi Arena	1 or 2	62 G 49151 D	6 oz.	9.99	8.99	7.99
Games by CBS Video for Atari 2600 console						
Mouse Trap	1 or 2	62 G 44804 D	6 oz.	14.99	12.99	11.45
Wizard of Wor	1 or 2	62 G 44800 D	6 oz.	9.99	8.99	7.99
Solar Fox	1 or 2	62 G 44801 D	6 oz.	9.99	8.99	7.99
Gorf	1	62 G 49125 D	6 oz.	9.99	8.99	7.99
Games by Spectra Video for Atari 2600 console						
Gangster Alley	1 or 2	62 G 49116 D	6 oz.	9.99	8.99	7.99
Planet Patrol	1 or 2	62 G 49115 D	6 oz.	9.99	8.99	7.99
Games by Fox Video for Atari 2600 console						
Beany Bopper	1	62 G 44411	6 oz.	4.99	—	—

*Write for a free copy of Manufacturer's Warranty, see page 497.

See page 535 for the Atari 2600 video game, joysticks and paddles.

See page 531 for our complete line of video game storage cabinets.

See page 533 for more Atari 2600 game cartridges at great savings.



Fathom



Q*bert



Zaxxon



Moonsweeper



Solar Storm



Donkey Kong Jr.



Frogger



Enduro

IMAGINE! IBM XT COMPATIBILITY, HIGH-SPEED PERFORMANCE

...at a price that won't take a big "byte" from your budget



Laser Turbo XT

\$799⁹⁹

\$20 MONTHLY ON
SearsCharge PLUS,
NO PAYMENTS
TIL JANUARY*

With built-in hard disk

\$999⁹⁹

thru
Nov. 30th only
\$25 MONTHLY ON
SearsCharge PLUS,
NO PAYMENTS
TIL JANUARY*

1 This computer has two built-in 5 1/4-in. disk drives plus 512K RAM—expandable to 1640K—enough to run the best-selling software for home or office. Color graphics adapter lets you use RGB, composite color/monochrome or TTL monitors. Also features built-in parallel printer interface, game/mouse port, turbo (4.77/10 MHz), real-time clock and RS-232 serial port for use with modem or printer. Microsoft MS DOS 3.3 and GW BASIC included. 5 1/2 open slots for expansion 150-watt power supply will support up to 2 hard disk drives. Imported. Warranted**.

3 E 32664C—Wt. 41 lbs . . . \$799.99
Same as (1) but, one floppy and one 20 megabyte hard disk drive.
3 E 32665C—Wt. 45 lbs . . . Thru 11/30/88 \$999.99
After 11/30/88 . . . \$1099.99

2 \$13 monthly, no payments 'til January*. Magnavox RGB/composite color monitor with 13-in. diagonal measure picture. 40-column readability with 1000 characters viewable at one time. Input for 80 columns and 2000 character readability. Tilt/swivel base. Compatible with every computer Sears sells. Incl. cables for Commodore and Laser XT computers. Imported. Warranted**.

3 E 32513C—Wt. 31 lbs . . . \$299.99
3 \$15 monthly, no payments 'til January*. Internal hard drive kit (with controller) for (1). Adds 20 megabytes of storage. Imported. Warranted**.

3 E 32195—Wt. 6 lbs . . . \$399.99
4 Magnavox high-resolution green monochrome monitor has 12-in. diagonal measure green screen, anti-glare glass. Composite video input. Tilt/swivel base. Interface cable incl. Warranted**.

3 E 32508C—Wt. 17 lbs . . . \$99.99
5 Sears 24-pin printer—the perfect printer for near-letter-quality. Order item (2) from opposite page.

Surge suppressor (not shown). Helps prevent damage to electronic equipment from voltage surges and "spikes". 6 protected outlets. 6-ft., 3-wire cord. For any computer we sell.
T 3 E 20898—Wt. 1 lb. 3 oz . . . \$29.99

Save \$50 to \$70

on computer combinations:

Computer (1) with monitor (4). Separate prices total \$899.98.
3 E 32671C—Wt. 58 lbs . . . \$849.98

Computer (1) with monitor (2). Separate prices total \$1099.98
3 E 32672N—Wt. 72 lbs . . . \$1029.98

*See page 305.
**Warranted by Sears or manufacturer. Write for free copy, see page 304.

NOTE: Catalog numbers with a "T" prefix may take extra time for delivery.



THE BEST SELLING CAMCORDER OUTFIT IN AMERICA!



Look at what your camcorder can do with optional lenses sold below



normal view



wide-angle view



with telephoto lens



with 6x zoom lens



Why? Because we give you more for your camcorder dollar:

- We include a hardshell case, adapters for TV, VCR and antenna hook-up and a 1-hr. rechargeable battery—most others charge extra for these features
- We provide a full 1-year warranty—most others give 90-day warranties
- We give you nationwide service and as always, **SATISFACTION GUARANTEED OR YOUR MONEY BACK**



• Prints date on tape

• Uses standard VHS tape

• Lightweight—only 4.2 lbs.

• Solid-state MOS element for a sharp picture

Full-sized camcorder with f1.6 lens has a metal oxide semiconductor (MOS) element that operates beautifully in light levels as low as 7 lux (comparable to light at dusk). Automatically focuses, sets the white balance and ins for perfectly exposed footage every time. 6x power zoom gets close-ups to 1 inch. Connects to your TV for playback of home movies or rental tapes and you can connect it to your VCR for dubbing. 3Wx6Hx14D in. Imported. Warranted by Sears.* Similar item (53741) \$1289.99 in our 1988 Spring General
O 57 E 53742C—Wt. 20 lbs. . \$999.99

Rechargeable batteries fit Sears, RCA and Hitachi full-size camcorders. Imported. Warranted.*
O 57 E 53994—1 hr. Wt. 1 lb. . \$39.99
O 57 E 53995—2 hr. Wt. 2 lbs. . \$79.99

Rechargeable 2 hr. battery for Panasonic camcorder.
O 57 E 53997—Wt. 2 lbs. . \$79.99

Get super close-ups from any camcorder with Super 4x telephoto lens (not shown). Converts 6x zoom to 24 power for very tight shots. Comes in a wood box with carrying case. Imported. Warranted.*
O 57 E 53957—Wt. 2 lbs. 5 oz. . \$289.99

Telephoto lens (not shown) gives 1.5 times magnification. Fits full-sized camcorders. Imported. Warranted.*
O 57 E 53954—Wt. 1 lb. . \$149.99

Wide angle lens (not shown) expands field of view 166 times. Fits full-sized camcorders. Imported. Warranted.*
O 57 E 53951—Wt. 1 lb. . \$69.99

*Warranted by Sears, write for free copy, see p. 304

Catalog numbers with an "O" prefix could take extra delivery time. †See page 305.

Get this camcorder outfit with new noise-reducing windswitch feature plus a 1.5x telephoto lens valued at \$149.99 for just

\$999.99 \$439

\$25 MONTHLY ON SearsCharge PLUS, NO PAYMENTS 'TIL JANUARY†

less than similar camcorder outfit and telephoto lens

Sears, Roebuck and Co. 55 ES 7707

8-digit Rechargeable Calculator with 4-key Memory System plus battery recharger/AC adapter

Only **19⁹⁵** Complete

- Mixed and chain calculation ability for adding, subtracting, multiplying, or dividing individually or in combination
- Automatic constant in all 4 functions
- Full floating decimal system
- Percentage key for interest, taxes, etc.
- Legible green display



A Great Gift Value

Save \$30

on Rockwell Advanced Slide Rule Calculator

Now Only **39⁹⁵**

This special price ends Dec. 25



AC adapter for [1] and [2] sold separately



APF M21 RECHARGEABLE CALCULATOR. The perfect calculator for home or office use. 4-key memory system (plus, minus, recall, clear). Exchange key returns previous display. Automatic timed cutoff of display saves battery while still retaining calculation which can be redisplayed. Zero suppression. Overflow, memory-in-use, and low battery indicators. Plastic 3x6-in. housing. Uses 3 rechargeable nickel-cadmium batteries (included) or 120-volt, AC outlet—UL listed recharger/AC adapter included.

X 641-5541 A—Actual wt. 1.25 lbs.; mail. wt. 2.75 lbs. 19.95

SAVE \$10 on 3-pc. Memocorder Pocket Recorder Outfit*

Only **55⁸⁵**

Includes recorder, 1 mini-cassette, and foot pedal. Would cost \$65.85 if purchased separately



MEMOCORDER by Unitrex. Mini dictating machine can record, replay, rewind. Volume control, built-in microphone with automatic gain control. 30-min. mini cassette (not included) can be removed and re-inserted at any time. Includes two "AA"-cell batteries, one 9V battery, along with vinyl carrying case, earphone. Plastic housing 2 3/4 x 5 3/4 x 1 1/4 in. Actual wt. 12 oz.; mailing weight 1.20 lbs.

X 641-6119 A 54.95*

30-Min. Mini Cassette. X 641-6101 A—Wt. 0.25 lb. 3.95*

On/off Foot Pedal. X 641-6127 A—Wt. 1.20 lbs. 6.95*

*To order combination, state all 3 catalog numbers, add up weights, pay only 55.85

A Great Gift Value

SAVE \$40 on Our Finest Cartridge-ribbon, Power-return Electric Typewriter

Now Only **199⁹⁵**

This special price ends Dec. 25



CARTRIDGES MAKE RIBBON CHANGING QUICK AND EASY with no mess. 2 cartridges included (1 fabric, 1 carbon). For corrections, simply pop out the cartridge, snap in a correction cartridge (order below), and type over mistake. Full 44-key, 88-character keyboard, 3 repeat-action keys (hyphen/underscore, period, and x) and automatic space bar. Personal-touch selector. Quick-set margins. Full tab. Line indicator, page gauge. Copy set dial. Aperture for vertical or horizontal line drawing. Back-space key. Variable line spacing. Paper support arms. Erasure table, paper guides. Stencil setting. Line retainer. Steel body and frame—black, gray, and white finish. High-impact molded plastic case with lock. 115 volts, AC, UL listed. Mailing weight 31 lbs. Full 1-year repair/replacement warranty, limited additional 4-year parts warranty—see below. Reduced from our big Fall '76 Catalog—see page 730. After Dec. 25, order at Reg. price.

X 641-4437 A—Pica type style. X 641-4460 A—Elite type style. Reg. \$239.95; NOW 199.95
Correction Cartridge for above. Packages of 2. X 641-6770 A—Mail. wt. 1.20 lbs. 1 pkg. of 2 for 4.59

JCPENNEY FULL ONE YEAR WARRANTY

Within one year of purchase, we will repair or replace at our option this JCPenney Typewriter if defective in material or workmanship. Parts and labor are included. Just return it to JCPenney.

LIMITED ADDITIONAL 4-YEAR PARTS WARRANTY

After the first year from date of purchase we will, for the following four years, provide replacement parts, without charge, for this JCPenney Typewriter if defective in material or workmanship. Labor of installation is not included. Just return it to JCPenney. Rubber parts and Electric Motors are not included by this warranty.

Charge it—see page 334

2 Rockwell Slide Rule Calculator

Only **26⁹⁵**

1 ROCKWELL 64RD CALCULATOR. 12-digit green display with scientific notation (8-digit mantissa with sign, 2 digit exponent with sign). Converts polar coordinates to or from rectangular coordinates in either degrees, radians, or grads. 3-key memory system (plus, store, recall). Plastic body measures 3 1/4 x 6 1/4 in. Actual weight 0.70 lb. Reduced from our big Fall '76 Catalog—see page 733. After Dec. 25, order at Reg. Price.

X 641-6044 A—Mailing weight 2.25 lbs. Reg. \$69.95; NOW 39.95
X 641-5582 A—AC adapter for above. Mail. wt. 1.20 lbs. 4.99

2 ROCKWELL 44RD CALCULATOR. 9-digit green display with scientific notation (5-digit mantissa with sign, 2-digit exponent with sign). 2-key memory system (store, recall). Plastic body measures 3 x 6 1/4 in. Actual weight 1.25 lbs. X 641-6150 A—Mailing weight 1.75 lbs. 26.95
X 641-5582 A—AC adapter for above. Mailing weight 0.50 lb. 4.99

Battery Recharger/AC Adapter Kit (not shown). Allows [1] or [2] to operate on 3 rechargeable nickel-cadmium batteries (incl.) or 110-120 volts, AC, UL listed. X 641-6143 A—Mailing weight 2 lbs. 9.95

Meet the "Little Professor" from Texas Instruments

- Displays over 16,000 pre-programmed problems to test a child's basic knowledge of math (+, -, x, ÷)
- 4-degrees of difficulty

19⁹⁵



EASY-TO-OPERATE. Select function to be tested and degree of difficulty. Press "Set" and "Go" keys and first problem is displayed. Child has 3 chances to give correct answer. After correct answer (or pressing "Go" key) next problem is displayed. At end of sequence, number of correct answers is displayed. Uses disposable 9-volt battery (not incl.). 3x5 in. plastic body, Act. wt. 1.20 lbs. Mail. wt. 1.70 lbs. For ages 5 to 9.

X 641-6176 A 19.95 JCPenney 277



Save \$20 Automatic phone answering system 209⁹⁸

- Answers calls while you're away
- Delivers your message, takes caller's message so you can answer later
- Monitor mode helps protect you from unwanted or annoying calls

Answers automatically on 1st to 4th ring. Single knob control, separate volume control. With 60-second announcement cassette and 60-minute incoming message cassette. Outgoing messages have variable length announcement. Operates from AC outlet. DOC approved — contact phone company for hook-up to telephone system, mini-plug included. Woodgrain-look housing of high-impact plastic, brushed aluminum control panel. About 11 1/4 x 11 1/4 x 2 3/4", weighs abt. 5 lb.

032 526 190 DL — Regularly 229.98, Ea. 209.98

4-Prong Adapter — if mini-plug not applicable.
032 526 152 — Each 6.99

New! Chess Challenger[®] 7 199⁹⁸

- Match your chess skills against the brain of the computer
- Choose from 7 levels of difficulty from beginner to expert; plus 'Mate in Two' and 'Chess by Mail'
- Easy to use — enter your move on the keyboard, computer replies in seconds
- Large, easy-to-read, L.E.D. display
- The ultimate gift for a chess player

Woodgrain-look housing of high-impact plastic, about 12 1/4 x 8 x 1". Staunton design chessmen. Comes in its own gift/storage box.
032 562 040 L — Each 199.98



1-2 Cross[®] Engraved Writing Instruments.
State name or initials to be engraved (up to 16 letters or spaces, please print). Toronto-shipped, allow 3 weeks for delivery — sorry, no COD's. Slim-profile, perfect balance. Gift-boxed.

- (1) 1/20 12K. Gold-Filled Pen/Pencil Set.
032 554 114 FTX — Each set 60.00
032 554 113 FTX — Pen only, Each 30.00
- (2) Chrome Pen/Pencil Set.
032 554 112 FTX — Each set 30.00
032 554 110 FTX — Pen only, Each 15.00

3 Sheaffer White Dot Chrome Pen/Pencil Set.
032 554 135 — Gift-boxed. Each set .. 10.00

4 Targa[®] Rolling Writer — a brushed chrome ball pen that writes with the smooth flow of a fountain pen or marker. Gift boxed.
032 554 120 — Each 15.00

5 Sheaffer Kaleidoscope. Refillable plastic ball pens. State no.: 01(Music/Black), 02(Birds/Orange) or 03(Ship/Brown).
032 554 136 C — Each 3.98

6 Parker 25 Pen/Pencil Set in matte Black metal with brushed chrome clips.
032 554 131 — Gift-boxed. Each set. 20.00

7 Fisher Space Pen[®] writes at any angle, up to 3 times longer than other pens.
35(Gold color) or 95(Chrome color).
032 554 115 C — Gift-boxed. Each 7.50

8 Chromatic[®] 2-Color Pen — twist for Blue or Red. 95(Chrome color), 09(Matte Black).
032 554 123 C — Gift boxed. Each 4.98

9 6 Candy Cane Pens. Peppermint-scent ink.
032 554 126 — Pkg. of 6. Each pkg. 2.49

10 Stencil[®] Phone Pen sticks to any dry surface, coil stretches up to 8 ft.
032 554 148 — Asstd. colors, boxed. Each . 5.95

11 Stencil[®] Pen/Pencil Set in vinyl pouch.
032 554 149 — Asstd. colors. Each set 5.95

12 60 Prismacolor[®] Pencils. Professional quality, all different colors.
032 554 128 — Gift/storage box. Each set. 19.25

13 48 Buffalo Medium-Point Markers. All different colors, professional quality.
032 554 127 — Gift tin box. Each box 21.00

Olivetti portable with
cartridge-load ribbon

149⁹⁸

- A full-featured manual with the no-mess cartridge-load ribbon
- 9½" carriage, 8½" line-of-write; 88-character keyboard, pre-set tab
- Segment shift gives perfect type alignment for a neater page
- Black nylon cartridge included.

A Portable, practical, easy to use... a perfect gift, just in time for Christmas. The Lettera 12 has all the features above plus personal touch control, horizontal and vertical line spacing, repeat forward and back space, touch-set margins. High-impact plastic body, snap-on case. About 14½ x 13 x 5" high, weighs abt. 11½ lb.

Pica Keyboard (10 characters per inch).
032 540 288 DL—English. Each ... 149.98
032 540 289 DLT—French. Each ... 149.98

Replacement Nylon Cartridge Ribbon for Lettera 12. 03(Black), 04(Red), 05(Blue).
032 540 696 C—Each 3.49
Item with 'T' in cat. no. Toronto-shipped



A



Save \$20

Canon P10D
display/printer 109⁹⁸

- Print-and-display or display only
- Prints on regular 2¼" tape
- Rechargeable batteries, recharger included; addressable memory

B Fits into a briefcase but has all the features above, plus: buffered keyboard; 10-digit fluorescent display; automatic % key; decimal positions 2, 3, floating or add-mode. Automatic constant (x, +, %); non-add key; item key count. Includes cassette ink roller and one roll 2¼" tape. Abt. 4½ x 8½ x 1½"; weighs abt. 1 lb. 8 oz.

032 541 512—Reg. 129.98. Each ... 109.98
Extra 2¼" Tapes for Item B. Package of 3.
032 545 504—Each package 2.69
032 541 188—Extra ink roller. Ea. 3.49

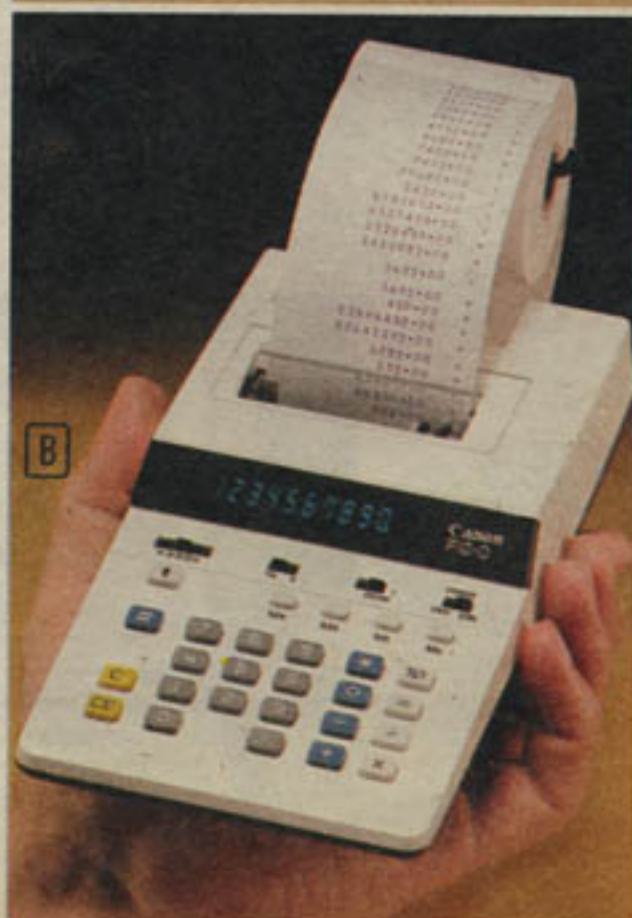

B

Telephone
amplifier 19⁹⁹

- Amplifies incoming voice for 2-way hands-free conversation
- Battery operated, completely portable, needs no installation

C A real convenience at home or at the office—frees you to write, type, file, or do housework while you use the telephone. Separate speaker, volume control, powerful solid-state circuits. No installation—just place phone in cradle. One 9-volt battery (sold on Page 335) gives abt. 500 hr. use. Abt. 9 x 4 x 3". Telephone not incl.

032 526 402 DL—Each 19.99



C

OUR BEST-SELLING BEGINNER'S COMPUTER — THE COMMODORE 64C



Cut \$30

\$149⁹⁹ \$10 MONTHLY,
NO PAYMENTS TIL JANUARY*

Save \$30 to \$50
on computer combinations



Built-in Microsoft® BASIC language. 40-column, 25-line display on your TV or order monitor (2). 64K RAM memory can hold up to 27 double-spaced typewritten pages. 16-color capability reproduces games with close to arcade quality. 66-character keyboard includes upper and lower case letters, graphic characters and 4 programmable special function keys. Warranted.** Made in USA of imported components. Was \$179.99 in our 1988 Fall General.

3 E 32120—Wt. 10 lbs. 4 oz. . . \$149.99

256K memory expansion module for (1). Warranted.** Imported.

3 E 32119—Wt. 1 lb. . . \$149.99

Cut \$11. 1200-baud modem (not shown) lets Commodore computers communicate with other Commodore systems over phone line. Warranted.** Imported. Was \$99.99 in our 1988 Fall General.

3 E 32554—Wt. 6 oz. . . \$88.88

*See page 304.

2 \$13 monthly, no payments 'til January.* Magnavox 13-inch diagonal measure RGB/composite color monitor has 40-column readability with 1000 characters viewable at one time. Input for 80 columns and 2000 characters readability. Tilt/swivel base. Compatible with every computer we sell. Cables included for Commodore and Laser XT computers. Warranted.** Imported.

3 E 32513C—Wt. 31 lbs. . . \$299.99

3 Cut \$20. \$10 monthly, no payments 'til January.* Commodore 1541 II disk drive for 64C, C64 and C128 computers. Loads and saves a program in about 20 seconds. Warranted.** Imported. Was \$219.99 in our 1988 Fall General.

3 E 32131—Wt. 11 lbs. . . \$199.99

4 \$10 monthly, no payments 'til January.* Okimate 20 printer prints in 100 colors at 80 CPS (characters per second), 40 CPS near letter-quality. Expanded, bold, fine print, italics, underlining, superscripts and Subscripts. Order Plug 'n' Print module above, right. Imported. Warranted.**

3 E 32413—Wt. 7 lbs. . . \$149.99

Plug 'n' Print module connects (4) to Commodore computers.

3 E 32414—Wt. 3 lbs. . . \$79.99

Replacement ribbons for (4). Wt. 3 oz.

T 3 E 32800—Black . . . \$3.99

T 3 E 32801—Color . . . \$4.99

Computer combinations:

Computer (1) with disk drive (3). Separate prices total \$349.98.

3 E 32164C—Wt. 21 lbs. . . \$319.98

Computer (1) with monitor (2) and disk drive (3).

Separate prices total \$649.97.

3 E 32165C—Wt. 52 lbs. . . \$599.97

**Warranted by Sears or manufacturer. Write for free copy; see page 304.

Note: Catalog numbers with a "T" prefix may take extra time for delivery

SEGASCOPE™ 3-D system takes you there

✓ THE SEGA LIGHT PHASER™ GUN

It registers hits and misses, letting you target in on the action



✓ SEGA CONTROL PADS™ are high-speed and super-responsive for easy handling



✓ **SEGASCOPE™ 3-D GLASSES™** make the screen come to life with images so real you can almost touch them!

✓ **THE SEGA POWER BASE™** is a state-of-the-art system console that handles all the action with loads of memory (128K)

✓ **MISSILE DEFENSE 3-D™ Mega Game Cartridge** will astound you with its 3-dimensional graphics and action!



1 and 2 Sega systems get you involved... if you want more realism, more force and more action on the screen, you'll appreciate the power of Sega. Systems and accessories are made of high-impact plastic. Imported. Warranted by Sega*. Not recommended for ages under 10 years.

1 The SegaScope™ 3-D set is so advanced you'll find it's perhaps the most challenging video game hardware available. Set comes with high-tech SegaScope™ 3-D glasses with synchronized liquid crystal shutters that make the screen come to life. Power base houses microchips that provide high-quality graphics; takes both the cartridge and the Sega Card™ for a large selection of games. Set also includes 2 control pads, Light Phaser™ gun, Missile Defense 3-D™ game cartridge, AC adapter and hookup accessories. 49 N 64715—Wt. 8 lbs. 10 oz. . . . Set \$149.99

The Sega Master System™ includes power base, 2 control pads, Light Phaser™ gun and Hang-On/Safari Hunt™ game cartridge. AC adapter and hookup accessories also included. 49 N 64701—Wt. 7 lbs. 13 oz. . . . Set \$109.99

2 Double the power and double the fun! Control Stick™/Rapid Fire Unit™ Combo adds new dimensions to the action. The controller has a large grip and high-speed response for faster action while the rapid-fire unit plugs in to let you switch to rapid firing at will. Use with SegaScope™ System (1) or Master System™ listed above. 49 N 64748—Wt. 1 lb. 13 oz. . . . \$34.99

SegaScope™ 3-D glasses let you see the whole picture! Use with Master System™ above and 3-D games (14 thru 18) sold separately below. 49 N 64703—Wt. 1 lb. . . . \$59.99

3 thru 18 For arcade-quality graphics, each game offers all the color, music and fun that you'd expect. Play (14 thru 18) with SegaScope™ 3-D glasses (sold above). Warranted by Sega*. Order from chart below. Wt. 8 oz.

3 After Burner™	4 Alex Kidd: Lost Stars™	5 Alien Syndrome™	6 Aztec Adventure™
7 Blade Eagle™	8 Fantasy Zone™	9 Great Basketball™	10 Great Football™
11 Great Golf™	12 Maze Hunter™	13 Miracle Warrior™	14 Missile Defense 3-D™
15 Monopoly™ (3-D)	16 Rescue Mission™ (3-D)	17 Space Harrier™ (3-D)	18 Zaxxon™ (3-D)

Item	Description	Catalog Number	Price, each
3	After Burner	49 N 64786	\$49.99
4	Alex Kidd: Lost Stars™	49 N 64775	39.99
5	Alien Syndrome™	49 N 64761	39.99
6	Aztec Adventure™	49 N 64758	34.99
7	Blade Eagle™	49 N 64779	46.99
8	Fantasy Zone™	49 N 64769	34.99
9	Great Basketball™	49 N 64758	34.99
10	Great Football™	49 N 64714	34.99
11	Great Golf™	49 N 64762	34.99
12	Maze Hunter™	49 N 64757	44.99
13	Miracle Warrior™	49 N 64777	59.99
14	Missile Defense 3-D™	49 N 64716	44.99
15	Monopoly™ (3-D)	49 N 64756	49.99
16	Rescue Mission™ (3-D)	49 N 64765	34.99
17	Space Harrier™ (3-D)	49 N 64771	46.99
18	Zaxxon™ (3-D)	49 N 64763	44.99

*Write for free copy, see page 304.



1. The Talking Computer delivers the message. Match the number on the screen with a number on the keyboard and hear one of 6 characters deliver a message as you read it on the screen. Moving cartoon delivers the message on a TV screen-like display. Requires one "D" battery, sold on p. 459. 9x8½x7 inches high. Plastic. Imported. For ages 3 years and up. 49 C 45814—Wt. 2 lbs. 8 oz. . . **\$14.88**

2. The Magna-Doodle™ magnetic sketch box has several different magnetic writing tools to make designs. Use eraser bar to start over. Also can be hung on wall. 15x12x1 inches. For ages 3 years and up. 49 C 45142—Shpg. wt. 8 oz. . . **\$12.88**

3. The "Arts-and-crafts chest" features acrylic and fabric paints, watercolors. Also includes felt-tip markers, paint brushes, mixing cup, palette, table easel, sketch pad instructions and all other items shown. Everything stores in wood case. Carrying handle. For ages 8 years to adult. 49 C 45054—Wt. 4 lbs. 8 oz. . . **\$11.99**

4. The "Big Barn" activity set (not as illustrated) has more than 300 "things" to keep young minds and little hands busy. Incl. watercolors, brush, game books, slate much, much more. 14x11x9½-in. high barn is storage chest. For ages 3 yrs. and up. Not for children under 3 yrs. due to small parts. 49 C 45121—Shpg. wt. 3 lbs. . . **\$7.99**

5. New at Sears! Create lighted pictures with the Brite Box. Put the colored pegs into the holes on the box, then turn on the light for a dazzling display of color. Plastic and metal. Requires 2 "C" batteries, sold on page 459. For ages 3 and up. 49 C 45165—Shpg. wt. 1 lb. . . **\$6.88**

6. The Rainy Day Club House keeps kids entertained as they learn. Set incl. four 24-pg. story books, a puzzle, slate, crayons, 16 game books. Paperboard. For ages 3 to 6 years. 49 C 45147—Wt. 2 lbs. . . **\$5.99**

7. Etch-a-Sketch lets children draw line pictures by simply turning the knobs. Flip over and shake to erase. 9¼x8x1½ inches. For ages 4 years and up. 49 C 45128—Wt. 1 lb. 10 oz. . . **\$7.94**

8. Save those walls! Children will have some place else to draw with the Doodle Board. Set comes with 3 colorful, water-soluble pens and lots of paper. 10½x12½ inch writing surface. Refills sold below. For ages 3 years and up. 49 C 45145—Wt. 2 lbs. 5 oz. . . Set **\$6.99**

Refill for (8) above. Two 60-foot long rolls of bond paper. 49 C 45146—Wt. 1 lb. 8 oz. . . Pkg. **\$2.99**



Toys 'n Kids:

The first thing a child wants to know about a new toy is how it works. By deciding how they'll play with their toys, youngsters are practicing for decision-making they will face as adults. Challenging pre-school toys provide stimulating fun as children grow. See more about Toys 'n Kids, following the index of this catalog.





A

B

Changeable IBM "ball" typing element in 5 styles:

Pica
SCRIPT
Elite
COURIER
ORATOR

Save \$40
359.95
 Remington 880 with
 1-step correction

A No money down, \$18 a month.* The Remington 880 professional office typewriter is the perfect typewriter for at-home executives, writers, sales reps or anyone who needs a dependable business typewriter at an affordable price. The Remington 880 utilizes the IBM single ball typing element, the universal typing element for over 25 years. (1 pica ball is included). It allows quick interchanging of different balls (sold below) so you can suit the typestyle to the job. Dual error correction system corrects up to an entire line or a character at a time as easily as one, two, three! One-piece ribbon cassette just pops in and out for tangle-free, mess-free ribbon changes. Automatic repeat keys XXX, ... and --- plus back space and space bar. IBM keyboard configuration for quick-response feather-touch typing. Stationary carriage. Includes black/correction ribbon cassette. Mfr.'s Warranty.** Was 399.95 in our 1984 Fall Big Book, pg. 707.
 62 G 98347 MS—Ship. wt. 24 lbs. . . . now 359.95

B Interchangeable IBM type balls: 62 G 98348—Pica; 62 G 98349—Script; 62 G 98352—Elite; 62 G 98353—Courier; 62 G 98354—Orator. Wt. 3 oz. each each 18.99
 Ribbon cassette for 880. Package of 2.
 62 G 98351—Ship. wt. 1 lb. package 10.99

**Write for free copy of Mfr.'s Warranty, see page 497.



C

Save \$60
219.99 No money down
 \$15 a month*
 Smith Corona correction electric III

• Easily corrects your mistakes

C Now you can correct your errors automatically. Two-step keyboard correction covers single characters or whole words neatly and quickly. Easiest method on any portable electric. Full range, key set tabulator permits rapid typing of complex statistical material. Segment shift. 12-in. powered carriage return, repeating spacer, backspace and xox/XXX, ---/---, . . . , keys. 1, 1½, 2, 2½, 3 and variable line spacing. Impact control adjusts for multiple copies. Includes double-walled carrying case.

Made in Singapore. Manufacturer's Warranty.** Was 279.99 in our 1984 Fall Big Book, page 707. Order below in either pica or elite type.

62 G 98355 MS—Pica type. Wt. 25 lbs. . . 219.99
 62 G 98356 MS—Elite type. Wt. 25 lbs. . . 219.99

Black/correction spool ribbon. Ship. wt. 4 oz.
 62 G 98331 D. each 3.99; 2 for 6.99

See more electric typewriters on pgs. 526 and 527.



Star Wars® Clock

27⁹⁵

"What R-2 D-2 is saying is that you have to get up right away!"

A

Timepieces That Are Out of This World

A Star Wars® Talking Alarm Clock. R-2-D-2 and C-3-P-O wake you up with a 20-second message. Large, easy-to-read, full-numeral dial. Sweep second hand. Durable molded-plastic construction. Measures 8½x6¼x3¾ in. high. Uses one C-cell battery (not included)—order on page 461. Warranted by manufacturer—write for copy, see page 363. Del. wt. 2 lbs. X 642-0830 A 27.95

©1990, 20th Century Fox Film Corp.

B Darth Vader® LCD Digital Watch. Darth Vader from Star Wars will issue the hour, minute, second, month, and date at the push of a button. Silvertone base-metal top case. Stainless steel back. Black vinyl strap. Warranted by manufacturer—write for copy—see page 363. Delivery weight 0.50 lb. X 642-0848 A 19.95

©1977-1980, 20th Century Fox Film Corp.

C Star Wars® Digital Watch. 5 functions at the push of a button—hour, minute, second, month, and date. Silvertone base-metal top case. Stainless steel back. Black vinyl strap. Warranted by manufacturer—write for copy, see page 363. Delivery weight 0.50 lb. X 642-0855 A 19.95

©1977-1980 20th Century Fox Film Corp.

D Star Wars® Watch. Full-numeral dial. Sweep second hand. Black Cyclocac® plastic top case and matching plastic strap. Warranted by manufacturer—write for copy, see page 363. Delivery weight 0.50 lb. X 642-0863 A 19.95

©1977-1980, 20th Century Fox Film Corp.

E Star Trek® Watch. Full-numeral dial. Sweep second hand. Black Cyclocac® plastic top case and matching plastic strap. Warranted by manufacturer—see page 363. Delivery weight 0.50 lb. X 642-0871 A 19.95

©1979, Paramount Pictures Corp.

F Black Hole® Watch. Full-numeral dial. Sweep second hand. Black Cyclocac® plastic topcase and matching plastic strap. Warranted by manufacturer—see page 363. Delivery weight 0.50 lb. X 642-0889 A 19.95

©1979, Walt Disney Productions





1 An all time favorite, Toss Across is the giant 3-D version of tic-tac-toe. Flip over the correct square when you toss your beanbag and you're on the way to winning. For ages 6 years and up. 49 N 62160—Shpg. wt. 5 lbs. 8 oz. . . \$12.99

2 Play over 100 different games on both sides of this reversible Carrom® board set. Hardwood board has polyethylene corners. Revolving stand has steel legs. Set includes carrom board, stand, 2 ring shooters, game book and all pieces for play. For 2 to 4 players. For ages 8 years and up. 49 N 62129C—Shpg. wt. 9 lbs. 7 oz. . . \$19.99

3 What fun! This arcade shooting game provides hours of excitement. Wind-up the target range and try to shoot down the targets before the motor runs out. Action rifle and dome are durable plastic. 6 1/2 x 6 x 25 1/4 in. long. For ages 5 years and up. 49 N 62162—Shpg. wt. 2 lbs. 8 oz. . . \$12.99

4 Far out! Sight, sound and motion, this is the ultimate electronic target game. The two pistols actually transmit a laser light beam. Hit the center of the master spaceship and you score. Built-in digital keeps score. For 1 or more players. Target uses 4 "D" batteries. Each pistol uses 3 "AA" batteries. Batteries sold on pg. 404. For ages 6 years and up. 49 N 62157—Shpg. wt. 2 lbs. . . \$27.99

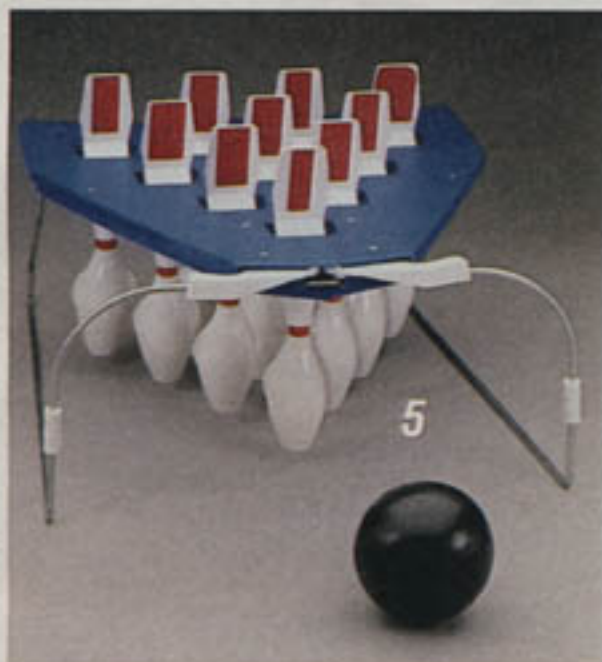

5 Action Bowl provides fun to spare! Now you can make strikes and spares just like in the bowling alley. When you hit the pins, they flip up. No loose pins to pick up . . . just squeeze the dual-action pin reset and you're ready to roll again! Includes ten 4 1/2-inch plastic pins with integrally-molded position markers and a large 2 3/4-inch diameter ball. For ages 8 years to adult. 49 N 62715—Shpg. wt. 2 lbs. . . \$9.99

6 You'll get a kick out of this table soccer game. Offensive kickers are positioned to maneuver ball through defensive line into the net pocket. Free-moving hardwood rods allow 2 to 8 players to compete in kicking and passing the ball. Metal telescoping player rods have easy to grip handles. Hardwood playing surface. Folding tubular steel legs. 42x20x30 in. high. For ages 5 to adult. 49 N 62155L—Shpg. wt. 19 lbs. . . \$79.99

7 Get indoor soccer action with deluxe KIK-IT®. Players manipulate offensive kicker figures to work ball through defensive line into the net pocket goal. Free-moving hardwood rods allow 2 to 6 players to match speed and dexterity in kicking or passing ball. Smooth decorated hardwood playing surface. 40x20x3 1/2 inches high. For ages 5 years and up. 49 N 62132L—Shpg. wt. 12 lbs. 8 oz. . . \$19.99

Toys 'n Kids:

Social play occurs whenever a group of children are talking and playing together. Through social play, a child learns about competition, good sportsmanship and the ability to concentrate and think quickly. Games encourage this kind of play. Excerpted from: THE ABC'S OF TOYS & PLAY; Toy Manufacturers of America, Inc.



A



B



C



D

Play chess with a computer

A Mini-sensory chess challenger is battery-operated and compact so it's ideal for play on car or plane trips, at the beach or picnic, in a hotel room or anywhere.

PLAYING BOARD: Advanced sensory playboard automatically recognizes and records your every move. Squares light up. LED's and beep tone inform you of computer's response. 3 levels of play incl. "Mate in Two" position verification by memory recall. Problem mode.

PIECES, CASE: Magnetized pieces. Compact, high-impact plastic housing. Uses six "AA" 1.5 volt batteries, not incl.; order on pg. 380.

53 T 2727—About 8½x4½x1½ inches. Ship. wt. 2 lbs. **54.97**

B Sensory Chess Challenger "sees" your move—sensory playing surface automatically tells the computer your every move. 8 levels of play from beginner to expert, fun games: "Mate in Two" and "Chess by Mail."

PLAYING BOARD: Squares light up graphically to show the computer's next move—you move pieces to keep track of pieces' positions. Double-move capability and En Passant. Problem mode and position verification by memory recall.

PIECES, CASE: Magnetized Staunton pattern pieces. High-impact plastic housing. For 120 volt, AC. UL listed. Also uses 4 "C" batteries, not incl.; order pg. 380.

53 T 2706 LS—About 11x10½x2½ in. high. Ship. wt. 3 lbs. **139.97**

C Champion Sensory Chess Challenger—winner of the first world micro-computer chess championship tournament.

PLAYING BOARD: Sensory playing surface; you move the pieces, surface automatically tells computer every move you make. Even "thinks" on opponent's time for a faster response. Also has ability to back up at least 2 moves in case you decide to change direction of your game. Programmed to duplicate 64 of world's greatest games. Computerized chess clock built in. Teaches on teaching level, too! 9 pre-determined levels of difficulty that you can select. Or let the computer automatically match your play from its infinite level.

PIECES, CASE: Hand-carved wood magnetized pieces. Solid walnut housing. 120 V., AC. 53 T 2729—UL listed. 7-ft. cord. Abt. 13x11½x3½ in. Ship. wt. 6 lbs. 6 oz. . . . **349.97**

D Chess Challenger "7" lets you choose from seven levels of difficulty from beginner to expert, plus fun games—"Mate in Two" or "Chess by Mail."

PLAYING BOARD: Position verification by memory recall, double-move capability, En Passant, problem mode. Select level of play, offense or defense position, your move. Computer responds on ½-in. LED display. 120 V., AC. UL listed.

PIECES, CASE: Magnetized Staunton design pieces. Simulated woodgrain plastic housing.

53 T 2704 LS—7-ft. cord. Abt. 12½x8x1½ in. Ship. wt. 2 lbs. 4 oz. **99.97**



F



G



H



E



I



K



J

Wishes for knowledge can come true in Sears Land, where on pages 402 thru 407, you'll find fun-filled learning aids



VideoSmarts™ is a VCR-interactive system that teaches numbers and size comparisons . . . also teaches letters, colors and shapes with additional cassettes



Oh, Pooh Quiz Pal™ 13



Spelling Starter teaches letter recognition and more 14



Alphie II teaches math skills, spelling, colors and more 6



Talk'n Play™ teaches colors, numbers, shapes and much more 8



Small Talk™ has 6 fun-filled activities and convenient tote handle 15

1 Teachin' Teddy™! 4-button computer connects with any VHS player and television. Asks educational questions and tells you if you're right or wrong. Offers animation and computer graphics. "Numbers 1-5/Comparisons" cassette included. Warranted by Connor*. Req. 4 "C" batteries, sold sep. on page 406. TV and VCR not incl. For ages 3 years and up. 49 N 17688—Wt. 2 lbs. 2 oz. . . \$44.99

2 thru 5 Additional 30-minute cassettes for (1).

Item/Description	Catalog No.
(2) "Colors and Shapes" teaches shapes and color combinations	49 N 17690
(3) "Letter Sounds" teaches phonics and spelling	49 N 17694
(4) "Letters A to Z" teaches how to recognize letters	49 N 17692
(5) "Numbers 1-20/Comparison" teaches counting, location	49 N 17693

Wt. each 7 oz. . . . Each \$16.99

6 Alphie II uses games to help teach your child. 4 two-sided activity cards. Additional card sets sold above, right. Req. 4 "AA" batteries, sold sep. on p. 406. For ages 3 to 8 years. Warranted by Playskool*. 49 N 17631—Wt. 2 lbs. 8 oz. . . \$24.99

7 Package of 2 activity sets for Alphie II. Offers lessons for overlapping age levels. With 4 double-sided cards, game board and playing pieces. Includes "Numbers, Letters & Shapes", for ages 3 to 5 years and "Get Ready to Read", for ages 4 to 6 years. 49 N 17632—Wt. 1 lb. . . Pkg. \$9.99

8 Talk'n Play™ is the learning toy that really lets your child participate. The pre-recorded voice coordinates with the workbook to ask questions; you respond by pushing the colored buttons. "Can you find your way to Sesame Street"™ program included. Requires 4 "D" batteries, sold separately on p. 406. For ages 3 years and up. Warranted by Playskool.* 49 N 17752—Wt. 5 lbs. 8 oz. . . \$64.99

9 thru 12 Additional cassettes for (8). Each includes 2 cassettes and 2 full-color booklets. (9) 49 N 17791—Grover'n Goose Assortment (10) 49 N 17793—Fun'n Games Assortment (11) 49 N 17794—Disney Assortment (12) 49 N 17795—Sesame Street™ Assortment Wt. each 1 lb. . . Each set \$19.99

*Write for free copy, see page 304. **Trademark for Children's Television Workshop.

13 You'll always get a lot of encouragement from your Oh, Pooh Quiz Pal™! Learn the alphabet, counting, colors, shapes and more, while providing colored lights and music reinforcement for right and wrong answers. Includes 80 lessons on 6 themes. Pencil probe is securely attached. Requires two "C" batteries, sold separately on page 406. Imported. Warranted by Shelcore*. For ages 3 to 6 years. 49 N 17607—Wt. 2 lbs. 12 oz. . . \$24.99

14 Spelling Starter uses pictures to help teach spelling skills. Unit automatically turns off after a few minutes of non-use. Eight learning activities. Requires 2 "AA" batteries, sold separately on page 406. For ages 3 to 7 years. 49 N 17630—Wt. 3 lbs. . . \$49.99

15 Take Small Talk™ wherever you go! Electronic, interactive activity center with six built-in activities including Talking Phone, Shapes, Animal Sounds, Numbers, Colors and Music. Tote handle and break-apart cord on phone. Requires 4 "C" batteries, sold separately on p. 406. For ages 2½ years and up. 49 N 17612—Wt. 2 lbs. . . \$29.99



'Sensor Touch'[®] from Sears

All-electronic tuning system—preset up to 12 channels (UHF or VHF)... position them in any sequence... then the mere touch of a finger brings the channel you want instantly, perfectly

Save \$50

Sears 20" color TV

729⁹⁷

REG. 779.98. One-button color control electronically sets color, tint, contrast, brightness. Light Sensor eye senses changing room light and automatically adjusts picture brightness. 100% solid-state chassis helps save energy. Precision 'In-Line' Black Matrix picture tube with slotted mask. Lighted channel indicators. Secondary controls hidden behind door. Walnut Woodgrain finish cabinet abt. 24" wide x 19" deep x 17" h.

572 514 087 DL—Each 729.97



Save \$100

Sears 26" color TV

969⁹⁷

REG. 1069.98. One-button color control adjusts color, tint, contrast, brightness. Light Sensor eye adjusts brightness to changing room light conditions. Dependable 100% solid-state chassis. Black Matrix picture tube. 75-ohm cable connector for improved cable reception. Beautiful cabinet with Woodgrain finish. Easy-roll casters. About 40½" wide x 21¼" deep x 31" high.

572 515 812 DL—Each 969.97

See our big Fall and Winter Catalogue,
Page 697 for Sears
complete color television guarantee



A
24.98



C 89.98

A Deluxe TV Cart. Walnut-stained wood rails; Walnut Woodgrain hardboard shelves. Casters. For TV's up to 20" screen. 26½ x 16 x 22" h. 572 540 560 DL—Assembles easily. Each 24.98

B Pedestal Stand. Woodgrain finish flakeboard top; polystyrene base. For TV's up to 20" screen. Casters. 27 x 18 x 16" high. 572 540 500 DL—Assembles easily. Each 39.98

C Home Entertainment Centre for TV's up to 20" screen. Also accommodates a music system receiver, record player and/or video cassette recorder. Deluxe Thermo-grain covered particle-board shelves; heavy vinyl extruded legs. Legs can be shown with either the heavy or narrow look. Overall 48 x 16 x 34½" h. TV opening 29¼ x 19¼" h. Accessories not included. Assembles easily. 572 540 915 DL—Each 89.98



B
39.98



(1) **SPEAK & LEARN** actually "reads" a book aloud to your child! As your child slides the magic wand over the Talking Tracks™ bar codes, a cordial, electronic voice speaks to beginning readers to help them associate printed words and phrases with their spoken sounds. 56-page storybook is included. Additional activity books sold below. 11x11x2½ in. Plastic. Requires 4 "D" batteries, not incl.; order below, or use AC Power Adapter sold below, right. Warranted by Texas Instruments. Write for free copy, see pg. 323.

For ages 4 to 7 years.
49 C 17835—Shpg. wt. 3 lbs. 13 oz. . . **\$39.99**

- Additional **SPEAK & LEARN** Books. 56 pgs. each.
- 49 C 17881—The Droopy Dragon
 - 49 C 17883—The Wonderful Sound Store
 - 49 C 17884—My First Animal Book
 - 49 C 17885—The Noisy Number Robots
 - 49 C 17886—The Alphabet Zoo
 - 49 C 17887—The Amazing Spiderman*
 - 49 C 17888—E.T.® Word Book
 - 49 C 17889—Zany Zingers
 - 49 C 17891—The Bernstein Bears on the Job
 - 49 C 17892—The Bernstein Bears Olympics
 - 49 C 17893—Sprites' Adventures on Earth
 - 49 C 17894—Scooter Computer and Mr. Chips
- Shpg. wt. 1 lb. Each **\$12.99**

*©Marvel Comics Group

(2) **SPEAK & SPELL** talks . . . teaches children to spell words by presenting spelling problems, praising them when they spell a word correctly or encouraging them to try again when they miss. It even plays spelling games with children . . . programmed for "Hang Man", plus two other games. Includes 32-page illustrated booklet. Accepts additional learning modules sold below. High-impact plastic; 10x2x7 inches wide. Uses 4 "C" batteries, not incl.; order below. Also uses AC power adapter sold at right. Warranted by Texas Instruments, write for free copy, p. 323. \$29.99 after Texas Instruments rebate (for Braille model, too); see p. 545 for details.

For ages 7 and up.
49 C 17807—Wt. 1 lb. 9 oz. . . Full price **\$39.99**

Braille **SPEAK & SPELL**. Raised braille-letter keys.
49 C 17833—Wt. 1 lb. 9 oz. . . Full price **\$39.99**

Additional Learning Modules for (2). Includes plug-in module and lesson booklet.

Module Type	Catalog No.	Grades
Basic Builders—helps sound out words	49 C 17837	2 & 3
Vowel Power—helps with vowel patterns	49 C 17838	2, 3, 4
Super Stumpers™—helps with problem words	49 C 17839	4, 5, 6
Mighty Verbs—helps with verb tenses	49 C 17843	4, 5, 6
Super, Super Stumpers—prepares for high school	49 C 17844	7 & 8
Vowel Ventures—helps with difficult vowel combinations	49 C 17845	6, 7, 8

Shipping weight 4 ounces Each **\$12.99**

E.T.® Movie Module for (2). Includes illustrated activity book, 16x24 in. poster and T-shirt iron-on decal. For grades 2 to 8.
49 C 17834—Shpg. wt. 4 oz. **\$12.99**
©"Extra Terrestrial" 1982 Universal City Studios, Inc.

(3) **SPEAK & MATH** "talks"; teaches basic math skills, decimals, algebra, geometry. Over 100,000 problems (incl. word problems), 4 activities and programmed game. Plastic. 10x11½x7 in. wide. Uses 4 "C" batts., not incl.; order below; or use AC Power Adapter sold below, right. Warranted by Texas Instruments. Write for free copy, pg. 323. \$29.99 after Texas Instruments rebate (Braille model, too), p. 545 for details.

For ages 2 to 8 years.
49 C 17605—Wt. 1 lb. 9 oz. . . Full price **\$39.99**

Braille **Speak & Math**
49 C 17606—Wt. 1 lb. 9 oz. . . Full price **\$39.99**

(4) **SPEAK & READ** "talks" . . . teaches vocabulary and reading. Programmed with 6 activities designed to help a child build vocabulary and reading skills. It helps a child recognize, pronounce and understand words. Accepts additional learning modules, sold below, to expand vocabulary. Includes 64-pg. activity booklet, earphone and carrying case. Yellow plastic, 10x11½x7 in. wide. Uses 4 "C" batteries, not incl.; order below; or use AC Power Adapter sold below right. Warranted by Texas Instruments. Write for free copy, pg. 323. \$29.99 after Texas Instruments rebate, p. 545 for details.

For ages 3 to 8 years.
49 C 17816—Wt. 1 lb. 14 oz. . . Full price **\$39.99**

Additional Learning Modules for (4). Includes plug-in module and booklet.

Module type	Cat. No.	Grade
Dog on a Log—rhyming words, plural endings	49 C 17822	1
On Track—consonant blends	49 C 17823	1
Who's Who at the Zoo—contractions	49 C 17821	2
A Seal that Could Fly—comparatives; long, longer, etc.	49 C 17817	2
Third Circle—"y" controlled vowels (e.g. "y" in circle)	49 C 17841	2

Shipping weight 4 oz. Each **\$12.99**

(5) **TOUCH & TELL** "talks", teaches reasoning and simple vocabulary . . . for preschoolers. Electronic voice gives names of objects, child responds by touching the correct picture. High impact plastic, 14½x11½x10 in. wide. Uses 2 "D" batteries, not incl.; sold below. Warranted by Texas Instruments, write for free copy, p. 323.

For ages 2 to 5 years.
49 C 17801—Shpg. wt. 1 lb. 13 oz. . . **\$29.88**

Extra Modules with picture overlays

Module Types	Catalog Number
E.T.®—Hear E.T.'s voice! 8 picture panels feature scenes from movie	49 C 17846
Alphabet Fun—Helps identify letters and words beginning with those letters	49 C 17849
Number Fun—Helps identify numbers and quantities	49 C 17851
Animal Kingdom—Helps with animal names and the sounds they make	49 C 17853
All About Me—Helps preschoolers discover "themselves"	49 C 17855
World of Transportation—All about buses, trains, planes & more	49 C 17857
Little Creatures—Helps learn about nature life	49 C 17859

Shipping weight each 10 ounces . . Each **\$12.99**

(6) **TEACH & LEARN Computer™** is designed to be your child's first computer, with a friendly voice and visuals. Your child will see an object, touch the picture overlay and hear a real voice, music or sound effects. It helps with reading, vocabulary, math, quizzes, stories, games, world knowledge, and many other areas. Basic unit incl. 2-sided program discs and three 2-sided corresponding overlays. More learning volumes below. Uses 2 "D" alkaline batteries and one 9-v. battery, not incl.; see below. Warranted by Mattel, write for free copy, see pg. 323. \$49.99 after Mattel rebate. Rebate offer ends December 31, 1983, see page 545 for details.

For ages 3 to 8 years.
49 C 17704—Shpg. wt. 1 lb. 8 oz. . . Full price **\$54.99**

Additional Learning Volumes. Incl. disc and overlay.

Learning Volume	Catalog Number	Age
Sesame Street™—learning about the Alphabet	49 C 17706	3, 4, 5
Sesame Street™—Learning about Numbers, words, shapes	49 C 17708	3, 4, 5
Reading Readiness™ I	49 C 17711	3, 4
Basic Learning™ I	49 C 17713	3, 4
Learning About People and Animals	49 C 17715	3, 4
Stories and Rhymes	49 C 17717	3, 4
Learning About my World™	49 C 17719	3, 4
Learning About Sounds	49 C 17721	3, 4
Reading Readiness™ II	49 C 17722	5, 6
Basic Learning™ II	49 C 17723	5, 6
Games and Mazes™	49 C 17724	5, 6

Shipping weight 8 ounces Each **\$11.99**

**Trademark Children's Television Workshop

Batteries for Electronic Learning Games

DieHard "D" Alkaline Battery. Pkg. of 2.
49 C 30939—Shpg. wt. 10 oz. Pkg. **\$2.39**

DieHard 9-volt Alkaline Battery
49 C 30949—Shpg. wt. 2 oz. Each **\$2.39**

DieHard "AA" Alkaline Battery. Pkg. of 2.
49 C 30909—Shpg. wt. 2 oz. Pkg. **\$1.99**

DieHard "C" Alkaline Battery. Pkg. of 2.
49 C 30929—Shpg. wt. 5 oz. Each **\$2.39**

AC Power Adapter (not shown). Eliminates need for batteries for Speak & Learn, Speak & Spell, Speak & Math and Speak & Read. Plugs into 110-120-v. electrical power socket. Converts power to 6-v. 6-ft. cord plugs into built-in jack on learning aid.

49 C 17806—Shpg. wt. 1 lb. 8 oz. **\$6.79**

When you can't go home for Christmas, send Christmas home with Ship-A-Gift . . . see page 322



THE COMPLETE

THE WRITE STUFF • GET TO WORK • TYPE THIS UP • INSTANT OFFICE

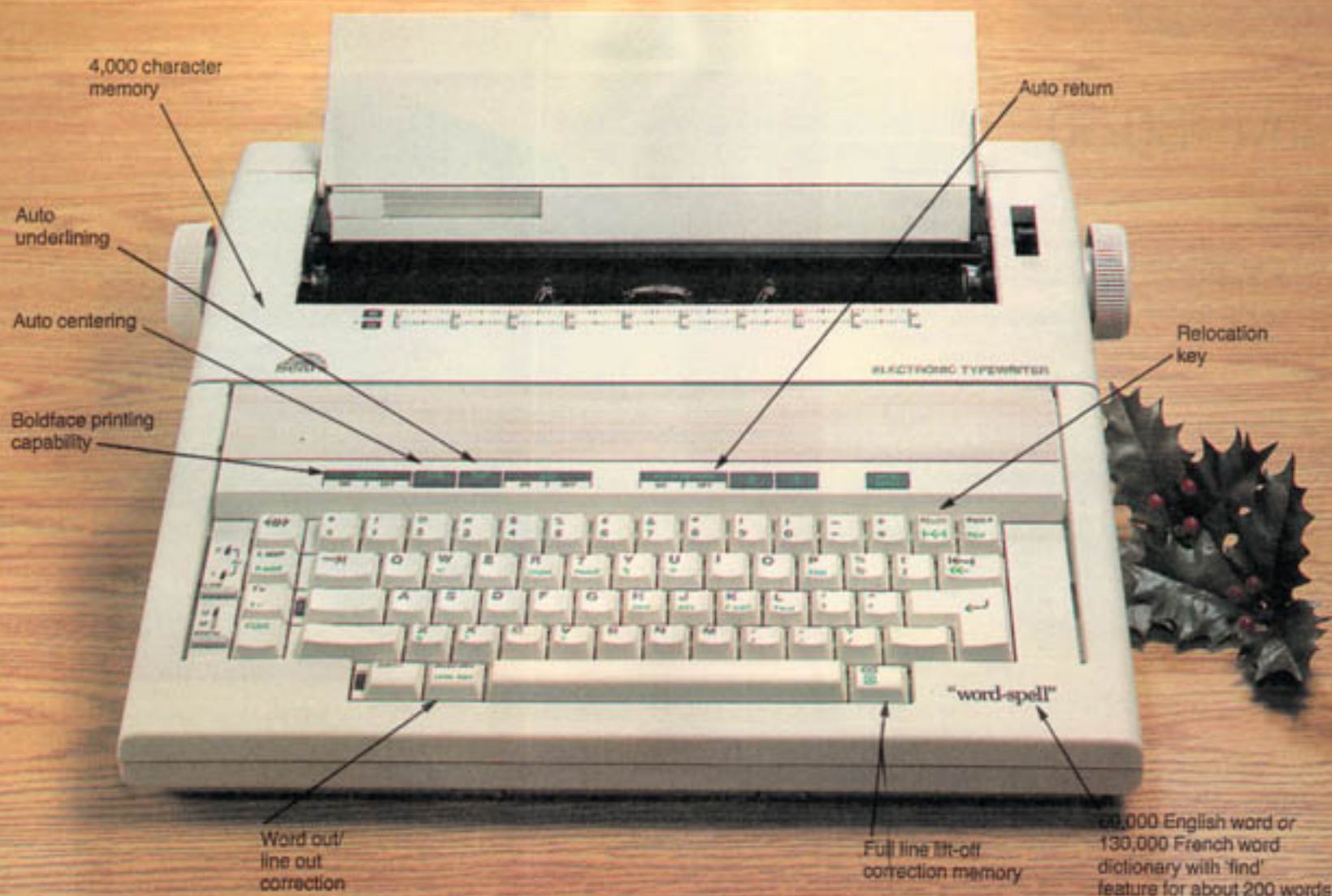

4,000 character memory gives the Celebrity 300 its state-of-the-art smarts

349⁹⁹

- "Word-Spell" dictionary has 60,000 English words or 130,000 French words; 'find' feature that locates errors
- Easy-to-use Daisy Wheel type system
- Automatic word-out/line-out correction system erases whole words or lines
- Boldface feature lets you highlight
- Express backspace, auto. repeat on all keys, auto. centering

Also features: 12" paper capacity, 9" print capacity, dual pitch typing (10/pica, 12/elite), typing speed of 12 characters per second. Auto. right margin flush, forward and reverse index. French model is shipped from Toronto, allow extra time for delivery.

032 540 401 DL—English. Each349.99
032 540 402 DLT—French. Each349.99

Starter Kit. Includes 3 carbon ribbons, 1 correction tape, 1 English or French script Daisy wheel.

032 547 634—English. Ea. kit49.99
032 547 635—French. Ea. kit49.99

Carbon Ribbon only.
032 547 630—Each7.99

Correction Tape. Package of 2.
032 547 620—Each package7.99



- Reliable Olivetti manual—great as a first typewriter, super for students
- Full 84-character pica keyboard
- Types 10 characters per inch

Olivetti "Lettera 25" manual typewriter with 10 inch line-of-write, 1-2-3 line spacing, easy-set margins. Stencil selection. Segment shift. Includes one Black/Red ribbon and carrying case. About 14 x 13 x 3 3/4" high. French model is shipped from Toronto, allow extra time for delivery.

032 540 020 DL—English model. Each129.99
032 540 021 DLT—French model. Each129.99
032 547 622—Replacement ribbon. Each3.99



1

3 3/4 x 6 in. **27⁵⁰**



2

3 5/8 x 5 7/16 in. **16⁵⁰**

Scientific Calculators with Memory Systems
Both [1] and [2] Feature:

- Bright green-on-black fluorescent displays
- Scientific notation ▪ Trigonometric and inverse trigonometric functions in degrees or radians
- Base e, base 10 logarithm/exponential ▪ Percentage key
- Solve square, square root, and reciprocals ▪ Pi key
- Mixed and chain calculation ability
- Floating decimal system ▪ Change-sign key
- Algebraic logic ▪ Clear/clear entry keys
- Warranted by manufacturer—see page 336

1 ADVANCED SCIENTIFIC CALCULATOR. 10 digit display with 8-digit mantissa, 2-digit exponents in scientific notation. Degree/radium functions. Obtains mean, variance, standard deviation and correlation. 3-key memory system (plus, clear, recall). Parentheses key. Uses 4 disposable "AA"-cell batteries (included) or 110-120 volts, AC—order AC adapter below. Molded plastic/aluminum body. Actual weight 0.50 lb.

X 641-8024 A—Mailing weight 0.70 lb 27.50
X 641-8032 A—AC Adapter for [1] UL listed. Mailing weight 0.50 lb 3.95

2 SCIENTIFIC CALCULATOR. 8 digit display with 6-digit mantissa, 2-digit exponent in scientific notation. 2-key memory system (plus, recall). Display-memory exchange key. Uses 2 disposable "AA"-cell batteries (included) or 110-120 volts, AC—order AC adapter below. Molded plastic/brushed aluminum body. Actual weight 0.40 lb.

X 641-8008 A—Mailing weight 1 lb 16.50
X 641-8016 A—AC adapter for [2] UL listed Mail. wt. 0.50 lb 3.95



Fits neatly into billfold (included)



2 3/4 x 4 1/2 in.

8-digit
L.C.D.
Calculator
and
Billfold Set

a great gift value

SAVE NOW ONLY **19⁹⁹**
\$10

This special price ends Dec. 24. After Dec. 24, order at Reg. Price.

- Easy-to-read Liquid Crystal Display helps provide a longer battery life
- 4-key fully-addressable memory system (plus, minus, clear, recall) stores number for future use
- Full floating decimal system ▪ Percentage key
- Sign-change key ▪ Square root key
- Black vinyl billfold has section for holding calculator and a section for credit cards, photos, etc.
- Uses 3 disposable "AA"-cell batteries (included)

MIXED AND CHAIN CALCULATION ABILITY—add, subtract, multiply, or divide individually or in combination. Brushed base-metal case. Actual weight 0.25 lbs. Warranted by manufacturer—see page 336. Reduced from our big Fall '77 Catalog—see page 757.

X 641-7323 A—Mailing weight 0.50 lb Reg. \$29.99; NOW 19.99



The "Little Professor"
from Texas Instruments

SAVE NOW ONLY **14⁹⁵**
\$5

This special price ends Dec. 24. After Dec. 24, order at Reg. Price

- Display over 16,000 pre-programmed problems to test a child's basic knowledge of addition, subtraction, multiplication, and division
- 4 degrees of difficulty
- Built-in battery saver
- Warranted by manufacturer—see page 336

Instant Replay Calculator
from Texas Instruments

ONLY **29⁹⁵**

- A touch of a key and previous entries (up to 20) are re-displayed. You can make corrections, press a second key and resume calculation no entries are lost!
- 8-digit green-on-black fluorescent display
- 2-key memory system (store, recall) stores numbers for future use



2 3/4 x 5 5/16

EASY TO OPERATE. First select the degree of problem difficulty by setting switch on side of machine. Next select arithmetic function by pressing appropriate key. Press "Set" and "Go" keys and first problem is displayed. Child has 3 chances to give correct answer. If incorrect answer is given, "EEE" lights up. After correct answer (or pressing "Go" key) next problem is displayed. At end of sequence, number of correct answers is displayed. Uses disposable 9-volt battery (not incl.). 3x5 in. plastic body. Ages 5 to 9. Reduced from our big Spring '77 Cat.
X 641-6176 A—Act. wt. 1.20 lbs. Mail. wt. 1.70 lbs. Reg. \$19.95; NOW 14.95

SAVES TIME, HELPS REDUCE ERRORS. Ideal for shopping, figuring taxes, budgets, etc. Mixed and chain calculation ability—add, subtract, multiply, or divide individually or in combination. Floating decimal system. Percentage key. Sign-change key. Rugged plastic body. Actual weight 0.25 lb. Uses 1 rechargeable nickel cadmium battery (included) or 110-volt AC—UL listed recharger/AC adapter included. Warranted by manufacturer—see page 336.

X 641-8040 A—Mailing weight 1 lb 29.95

Buy now with our Time Payment Plan—see page 341

JCPenney 275



You are the master in a real video arcade!

H, I Pocket Simon™ and Simon™ games. Step up in skill as sequence becomes longer, more difficult. Electronic "razz" for a goof. Flashes colored lights, sounds. 3 different games. Ages: 7 to adult.

(H) Save \$2. Pocket Simon. Hand-held version. Uses one 9V, 2 "AA" batteries (not included). 48 LT 14673—Ship. wt. 1 lb. thru Dec. 3, 20.99
You pay 22.99 after 12/3/84.

(I) Save \$3. Simon table top game. Uses one 9V, 2 "D" batteries (not included). 48 LT 14669—Ship. wt. 2 lbs. 8 oz. thru Dec. 3, 29.99
You pay 32.99 after 12/3/84.

J Save \$10. Zaxxon™—soar over alien lands, to conquer the Robot Warrior Zaxxon™. Lighted, 3-D color display; sound effects. Digital score; joy-stick control; dual fire buttons. Cut from '83 Christmas page 154. Ages: 8 to adult. 48 G 50032—Uses 4 "D" batteries (not incl.). Ship. wt. 2 lbs. 1 oz. was 49.99; now 39.97

K Save \$5 on Donkey Kong Junior™. Joy-stick control; multi-color display; digital scoring; sound effects. Uses 2 "C" batteries (not incl.). Appearance may vary slightly from model shown. Cut from '83 Christmas page 154. 48 G 50036—Ages: 8 to adult. Ship. wt. 1 lb. 12 oz. was 44.99; now 39.97

L Save \$5. Pac Man™ eats food dots, avoids monsters. Lighted, multi-color display; sound effects. Joy-stick controls, digital score display. Play three games at 2 skill levels. Uses 4 "C" batteries (not incl.), or Battery Eliminator below. Cut from '83 Christmas page 154. 48 G 50003 G—Ages: 8 to adult. Ship. wt. 1 lb. 12 oz. was 44.99; now 39.97

Perma Power™ Battery Eliminator/AC Adapter. (Not shown.) UL listed. Can also be used with Ms. Pac Man, Donkey Kong and Frogger electronic games. 48 G 50029 D—Ship. wt. 7 oz. alone 10.99; with Pac Man 5.99

M Save \$12. Q*bert™ has frantic, funny action of arcade game. Joy-stick controls; lighted, multi-color display; automatic scoring; sound effects. Cut from '83 Christmas page 154. 48 G 50040—Ages: 7 to adult. Uses 4 "C" batteries (not incl.). Wt. 2 lbs. 6 oz. was 49.99; now 37.99

N-O Chess Master and Backgammon to keep your mind sharp. Both hand-held games of strategy and tactics. Choose skill level. Play against the computer or an opponent. Batteries incl. Ages: 6 to adult.

(N) 48 G 51848—Chess Master. All legal moves. Ship. wt. 4 oz. 29.88
(O) 48 G 51849—Backgammon Master. Ship. wt. 4 oz. 24.88

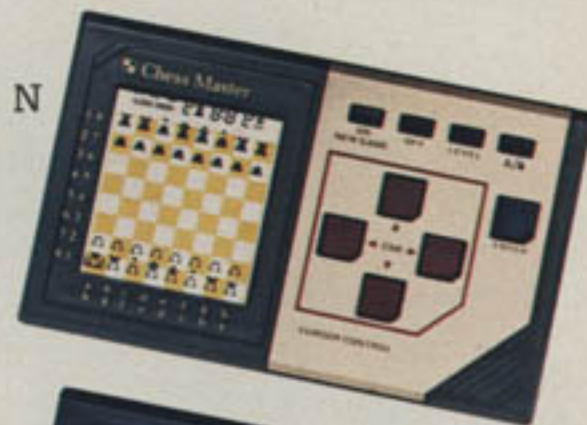

Grab the wheel and feel the power!

\$14.99



Sears Land

A toy store that really cares about you

Shopping for toys should be a happy experience. Sears Land promises to make it that. If ever you're not happy with what you buy at Sears Land, let us know. We'll be more than happy to make you happy again. That's our promise.

1 Watch where you are "driving" this sport car or you'll "turn off the road" on the "moving" screen. Turn the key and listen to the power! Sound the horn, shift into first, then second, and you're off. Don't forget to use the turn signals! Plastic. 11½x11½x6½ in. high. Requires 4 "D" batteries sold on p.406. Imported. For ages 3 years and up. 49 N 44386—Wt. 3 lbs. 2 oz. . . \$14.99

2 The Bear Walker has a clicking dial and play telephone. Activity set doubles as a pull toy. Bear moves up and down and squeaks as it rolls. Plastic. 11½x12¼x18 in. high. For ages 1 to 3 years. 49 N 47717—Wt. 4 lbs. . . Set \$16.99

3 The Sleepy Sounds white-noise generator produces the comforting sounds of a heartbeat and a mother's womb. Incl. volume control, automatic sound reduction and shutoff. Attaches to crib, playpen or lies flat. Plastic. 7x5x2½ in. high. Req. one 9-v. battery sold on p. 406. Imported. For ages up to 18 months. 49 N 48116—Wt. 1 lb. 4 oz. . . \$19.99

4 Delightful shapes and sounds . . . this 4-pc. gift set features activity ball, roller rattle, telephone rattle and pram rattle to stimulate coordination. Plastic. Imported. For ages 3 to 18 months. 49 N 48110—Wt. 1 lb. 7 oz. . . Set \$7.99

5 Bring the joys of the circus to your baby with this soft and cuddly musical circus clown. Simply turn the safety key of the 11-in. clown and a pretty melody plays to enchant your child. Surface washable acrylic, imported. For newborns and up. 49 N 47723—Wt. 1 lb. 2 oz. . . \$9.99

6 Musical snoozy Suzy nods her head as she sleeps. Turn the safety key and 12-in. Suzy will play a delightful tune to help lull your baby to sleep. She has a cotton pillow and an acrylic plush body stuffed with urethane foam and cellulose fibers. Surface washable. For ages 3 months and up. 49 N 47725—Wt. 14 oz. . . \$9.99

7 Your little one will take to these ducks like they take to water. Momma duck and her 2 babies can float around separately or place the little ones on their mom's back and let them take a ride. 9½x6½x5½ in. high. Plastic. For ages 8 months to 4 years. 49 N 48505—Wt. 5 oz. . . Set \$7.99

8 Little tikes will have fun navigating the bath waters with this 5-in. plastic tugboat. Also includes dinghy and 2 figures. For ages 3 years and up. Was \$5.99 in our 1987 Wish Book for Kids. 49 N 48144—Wt. 1 lb. 2 oz. . . Now, set \$3.99

Pinball and Pool Pack Plenty of Punch for Plenty of Fun!

1 Play real arcade pinball! The Wild Ride deluxe floor-model electronic pinball game has solid-state circuitry that creates 12 different scoring sounds and background music for the sights, sounds and excitement of an authentic game. 2-player feature displays scores in LED digital readout. 2 independent replay flippers. Professional-style ball loading. Plastic cabinet has steel playing base and legs. 41x18x55 inches high. Uses AC power; 12-volt adapter included. UL listed. Partially assembled. Not recommended for ages under 8 years. See "N" suffix note, p. 304. Wt. 44 lbs.
49 N 62645N... Thru 12/15/88 \$179.99
After 12/15/88... \$199.99

2 It's an action-packed battle through tropical forests with Jungle Fighter electronic pinball. Game includes professional-style ball loading, 12 scoring bumpers and 4 bonus score channels. Ringing bell and flashing light add to the excitement. 2 independent replay flippers. Steel playing base has high-impact plastic housing and steel legs. 38x19x53 inches high. Uses AC power. Partially assembled. Not recommended for ages under 8 years.
49 N 62608C—Wt. 34 lbs... \$149.99

3 BMX pinball is rad racing action! Features include professional-style ball loading, 10 scoring bumpers and 4 bonus score channels. Automatic scoring up to 100,000 (manual scoring up to 500,000). Flashing light and ringing bell make playing more fun. 2 independent replay flippers. Steel playing base with high-impact plastic housing. Tubular steel legs fold for easy storage. Uses AC power. 32x17½x50 inches high. Partially assembled. Not recommended for ages under 8 years.
49 N 62631C—Wt. 21 lbs... \$99.99

4 This tabletop model goes anywhere you go for exciting pinball action. Touchdown electronic pinball features realistic bumpers, fast-action sounds and clear digital scoring. Dual flipper controls. 3 balls per game. Measures 10x15½x7 inches high. Requires 4 "D" batteries sold separately on page 406. Imported. For ages 4 years and up.
49 N 62635—Wt. 4 lbs. 2 oz... \$19.99



'Tis the season to be jolly... so order early and avoid disappointment



Take a "Wild Ride" with our deluxe electronic pinball table
\$179⁹⁹
thru December 15

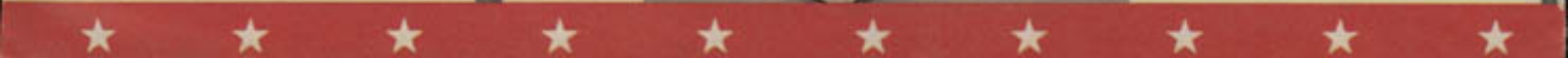



1. "Smart" is an electronic learning toy that's so much fun to play with, children might not realize they're learning. "Smart" automatically selects the game and skill level of the card that's being played. He helps young children to match colors and shapes, while older children can test their spelling skills. He also plays songs to sing along with or will play back your child's own 15-note melody. Correct answers earn a musical salute while "Smart" nods his head. For incorrect answers, he shakes his head from side to side to advise your child to try again. Includes 4 two-sided Smartware cards. Order additional cards below. Requires 4 "AA" batteries, sold separately on p. 459. Shuts off automatically when he's left alone, to conserve power. Warranted by Combi. Write for free copy, see page 335.
For ages 2 to 6 years.
Shipping weight 2 lbs. 8 oz.
49 C 17640... \$24.99

2. Smartware sets expand the activities you can play on "Smart" ... let the learning continue as children grow. Each set includes 4 double-sided cards. Shpg. wt. 6 oz.
Fundamental set; for ages 2 to 4 years.
49 C 17641... Set \$4.99
Advanced set; for ages 3 to 6 years.
49 C 17642... Set \$4.99

3. Give your child a boost in school and a friend as well with Albert™. He introduces children to basic skills, building a solid foundation for learning. A total of 120 lessons on 60 cards cover subjects like basic math, reading, shapes and more. Albert lights up and sounds his approval when your child answers the multiple choice questions correctly. His learning programs have already been used successfully by thousands of teachers. Requires one 9-v. battery, sold separately on page 459. Plastic. For ages 3 to 6 years.
Shipping weight 1 lb. 13 oz.
49 C 17625... \$19.99

4. Learning is fun with the Quizatron. Uses a combination of games, lights and sounds to help your child develop skills in math, logic, words and more. It responds to correct answers with a musical salute. 3 speed settings. Constructed of plastic. Requires 8 "AA" batteries, sold separately on page 459. Imported. Additional booklets available below. For ages 4 to 8 years.
Shipping weight 1 lb. 12 oz.
49 C 1779... \$29.99

Extra question booklets for (4). Each 38-page booklet contains 380 questions to challenge children 4 to 8 years.
49C17796—Level I, ages 4 to 5 years.
49C17797—Level II, ages 5 to 6 yrs.
49C17798—Level III, ages 6 to 7 yrs.
49C17799—Level IV, ages 7 to 8 yrs.
Shipping weight 8 oz. ... Ea. \$2.99

Save \$2 on complete set of question booklets for (4), levels I thru IV. Separate prices total \$11.96. Shipping weight 2 lbs.
49 C 17789... Set \$9.96





A

A 44-Level Chess Computer includes 2 built-in chess clocks. 16 levels of playing strength; 16 levels for fixed-time game; 8 teaching levels; 2 demonstration levels; 1 infinite level; 1 problem solving level. Selectable opening with more than 6,000 moves. User programmable library of over 240 moves. 4 different playing styles: normal, attacking, very aggressive, positional. Take-back feature—allows up to 120 half moves. Hint—assesses best move for opponent; verify position; game save...can replay whole game later; draw recognition; multi-move mode—checks validity of both players' moves. Many other features! About 14 x 2 1/4 x 18 1/2". Requires 4 'AA' batteries or universal adapter (both not incl.—batteries p. 398, adapter p. 395). 492 562 293—Each 219.99



B



F

B 16-Level Electronic Chess. Selectable book openings...approx. 300 positions. Position verification. Take-back—allows up to 4 half-moves; hint—assesses opponents best possible move. Checks legality of moves. Rejects illegal moves. Set-up/problem mode. About 13 1/2 x 2 1/2 x 14 1/4". Requires 4 'AA' batteries or universal adapter (both not included—batteries p. 398; adapter sold on page 395). 492 562 289—Each 149.99



C



G

C Sensory Electronic Chess with 8 levels of play. Verify position, take back, castling, en passant, pawn promotion. Abt. 11 x 13". Uses 4 'AA' batteries (not incl., see p. 398). 492 562 290—Each 99.99

D Limited Edition Chess Set. Weighted and felted. Deluxe inlaid wood chess board. Kings about 3 1/4" h. About 18 1/2 x 18 1/2 x 2". 492 562 282—Each 69.99



D



H

E Tapered Wood Chess Set. Pieces store inside felt-lined compartment. Inlaid playing field. Kings abt. 3" h. Open measures about 16 1/2" x 16 1/2". 492 562 044—Each 29.99

F Rummy Game with deluxe vinyl-covered attaché case; 106 tiles imprinted with card suits, 4 racks. About 15 x 8 x 2". 492 562 043—Each 29.99

G Quality Backgammon Set. 'High-tech' Grey vinyl case; Black velvet playing area. Attaché case about 10 1/4 x 2 1/4 x 7 1/2" closed. 492 562 004—Each 16.99



E

J

H Folding Cribbage Board...ideal for travel. Complete with deck of playing cards. Pegs store inside case when not in use. Plastic. About 1 1/2 x 6 1/4 x 3" when closed. 492 562 818—Each 5.49

J Plastic Automatic Card Shuffler can shuffle 1-2 decks with push-button operation. Cards not included. Uses 2 'C' batteries (not incl.—see p. 398). 492 562 118—Each 15.99

See our snow toys shown on pages 348-349

COMPUTE IN STYLE!



Oak-grained desk with hutch and storage area
\$129⁹⁹
\$10 MONTHLY, NO PAYMENTS TIL JANUARY*



Desk with monitor shelf and under-desk storage shelves; choice of finishes
\$89⁹⁹



Utility chair
\$29⁴⁹



Desk and hutch combination
\$199⁹⁸
\$10 MONTHLY, NO PAYMENTS TIL JANUARY*

Computer desks
Save \$40 to \$70

1 Features large work area, enclosed storage area and drawer. Adjustable shelves and leveling guides. Oak-grained finish on wood product construction. Measures 47Wx55Hx26D in. Ready to assemble. Was \$179.99 in our 1988 Annual Catalog. 3 E 61259N—Wt. 122 lbs . . . \$129.99

2 and 3 Hutch and desk are sturdy pecan-grained wood products with acrylic work surface. Finished on all sides. Unassembled.

2 Hutch attaches to (3) and has 2 adjustable shelves plus monitor shelf. 27 1/4 H x 47 W x 11 3/4 D in. 3 E 61277N—Wt. 50 lbs . . . \$99.99

3 Desk has storage shelf and half-width compartment with lockable doors. Rear cable management for neat appearance. Leveling glides. 26 H x 60 W x 27 3/4 D in. 3 E 61276N—Wt. 91 lbs . . . \$169.99

Combination of (2) and (3). Separate prices total \$269.98. 3 E 61291N—Wt. 141 lbs . . . \$199.98

4 Desk surface is 41Wx23D in. Monitor shelf is 40Wx9D in. Under desk shelves are 14Wx20D. Unit measures 41Wx37Hx23D in. Sturdy wood products with oak-grained finish. Unassembled. Was \$129.99 in our 1988 Annual Catalog. 3 E 61242N—Wt. 93 lbs . . . \$89.99

Same as (4) but with walnut finish (not shown). 3 E 61243N—Wt. 93 lbs . . . \$89.99

5 Comfortable and sturdy utility chair has back that adjusts up and down, forward and back. 245-sq. in. seat is padded with a full 1 1/2 inches of polyurethane foam. Durable acrylic fabric for long wear. Seat adjusts from 16 to 20 inches from floor. 5-spoke base for stability. 17 1/2 D x 15 1/2 W x 37 H in. 3 E 7501C—Wt. 20 lbs . . . \$29.49

Computer software Programs for productivity, education and entertainment



Software title	For computers			Wt.	Price
	Commodore 64, 128	Apple	IBM		
Test Drive. Get behind the wheel of your own Ferrari during a high-speed test.	O 3 E 20071		O 3 E 20072	1 lb. 5 oz. 1 lb. 5 oz.	\$26.99 39.99
Championship Baseball. The count is 3 and 2, the bases are loaded, and you are the boss . . . what do you call?	O 3 E 20073		O 3 E 20074	1 lb. 5 oz. 1 lb. 5 oz.	32.99 39.99
		O 3 E 20075		1 lb. 5 oz. 1 lb. 5 oz.	34.99
Print Shop. Print banners, invitations, and greeting cards for all occasions.	O 3 E 20076	O 3 E 20078		1 lb. 5 oz. 1 lb. 5 oz.	44.99 59.99
			O 3 E 20077	1 lb. 5 oz. 1 lb. 5 oz.	49.99
Advanced Flight Trainer. Fly with famous test pilot Chuck Yeager in this flight simulation.	O 3 E 20079		O 3 E 20080	1 lb. 5 oz. 1 lb. 5 oz.	34.99 39.99
		O 3 E 20081	O 3 E 20083	O 3 E 20082	1 lb. 5 oz.
California Games. Enjoy skate boarding, BMX biking and surfing in this arcade game.	O 3 E 20084	O 3 E 20086	O 3 E 20085	1 lb. 5 oz. 1 lb. 5 oz.	34.99 39.99
Gunship. AH-64 Apache attack helicopter simulation.	O 3 E 20087		O 3 E 20088	1 lb. 5 oz. 1 lb. 5 oz.	31.99 49.99
		O 3 E 20089	O 3 E 20091	O 3 E 20090	1 lb. 5 oz. 1 lb. 5 oz.
The Writer. Complete word processor	O 3 E 20092	O 3 E 20092	O 3 E 20092	1 lb. 5 oz.	9.99
Wheel of Fortune™. Popular TV game show.	O 3 E 20093	O 3 E 20095	O 3 E 20094	1 lb. 5 oz.	12.99
Jeopardy™. The TV game show for your computer.	O 3 E 20096	O 3 E 20098	O 3 E 20097	1 lb. 5 oz.	12.99
Top Gun. You are "Top Gun" in this popular flight entertainment package.	O 3 E 20099		O 3 E 20100	1 lb. 5 oz.	9.99

Catalog numbers with "O" prefix could take extra time for delivery.

Test your skills



WISH BOOK VALUE Cut \$3 \$7.99

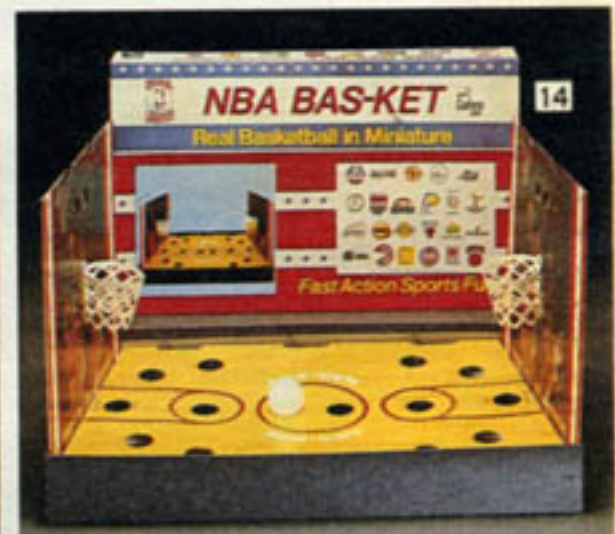

Available only at Sears... ring shooter for accuracy, power

Adopt a robot, then watch all the things it can do!

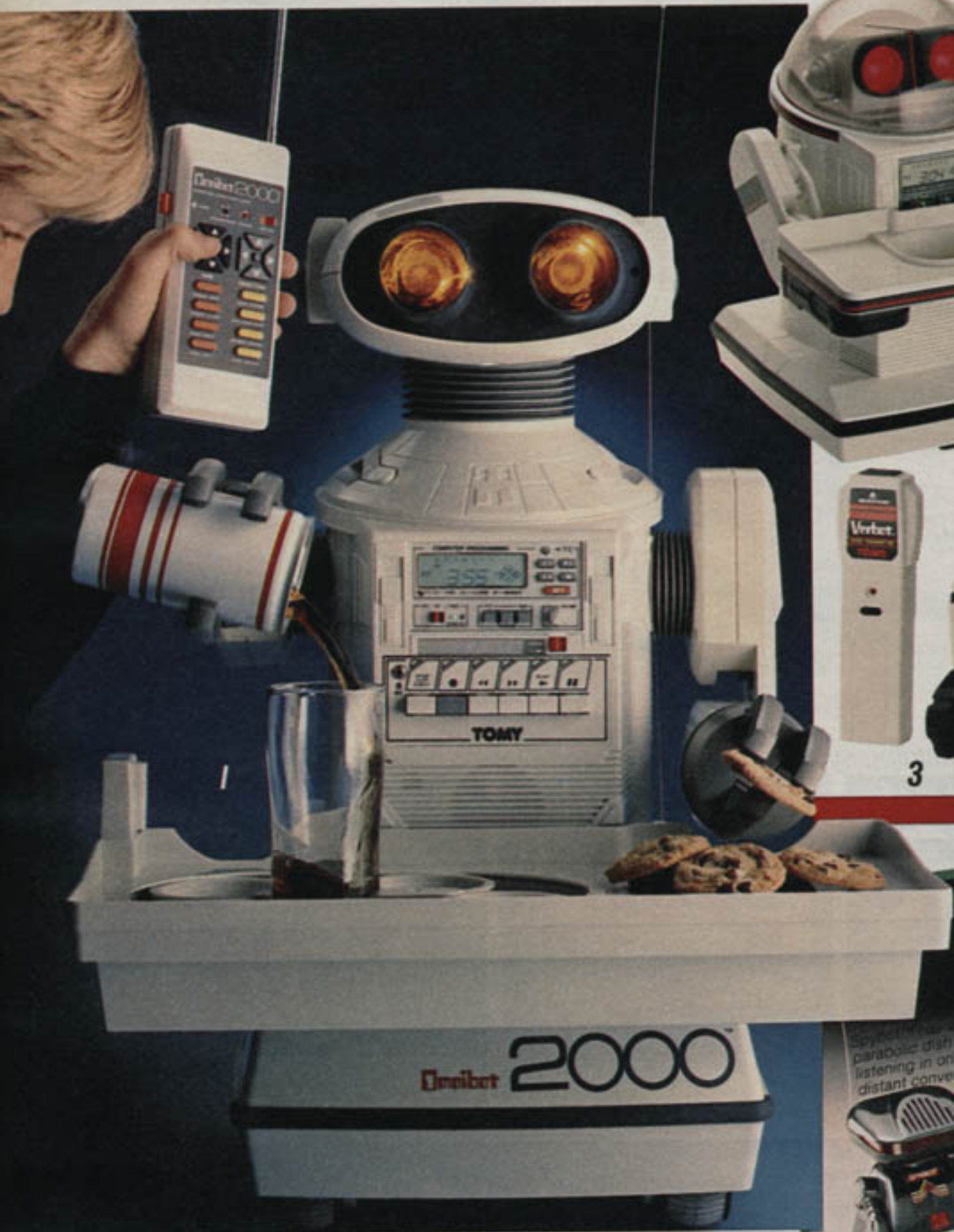

Omnibot™ moves in whatever direction you want it to!

Verbot™ responds to your voice commands



3



Spybot™ has a parabolic dish for listening in on distant conversations

4

(1) Ever thought of how nice it would be to have a robot do your chores? The Omnibot 2000™ can serve snacks from its tray and even pour drinks!

1 Omnibot 2000™ can be the life of your party. It can bring you things, pour and serve drinks or hors d'oeuvres from its detachable tray. The articulated arm and grasping hand serve everything smoothly. Cassette tape player adds the party music. 7 day/24 hour programmable timer/tape memory enables this robot to remember your every need.

The remote control unit commands all functions. Omnibot 2000 can move at two speeds over almost any surface... even shag carpeting. Moving head and flashing eyes add "life". Rechargeable 6-volt battery and recharging unit incl. Requires 6 "AA" batteries, sold separately on p. 404. 26 in. tall. Plastic and metal. Warranted by manufacturer. Write for free copy, see p. 371. For ages 9 and up. 49 N 54585C—Shpg. wt. 26 lbs... \$499.99

2 Omnibot™ moves forward and backward then turns right and left, has a manual grasping hand and carries objects on his detachable tray. 7 day/24 hour timer/tape memory. Its eyes light when he talks. 18 in. tall. Built-in rechargeable battery and recharging unit incl. Requires 6 "AA" batteries sold on p. 404. Plastic and metal. Warranted by manufacturer, write for free copy, see p. 371. Ages 9 years and up. 49 N 54582C—Shpg. wt. 16 lbs... \$249.99

3 Verbot™ use its wireless remote microphone to order him to move forward, backward, turn right or left and pick up objects. 9 in. high. Req. one 9-volt and two "C" and 4 "AA" batteries sold separately on p. 404. Plastic and metal. Warranted by manufacturer. Write for free copy, see p. 371. Ages 7 years and up. 49 N 54574—Shpg. wt. 3 lbs. 3 oz... \$59.99

4 Spybot™ is a master of espionage. Its parabolic dish enables it to listen to a conversation an avg. of 49 ft. away! Range can vary. Transmits conversation to controller/listener. Wireless controller. Moves forward, turns when moving backward. Manually movable arms, grasping hands. Plastic. Warranted by manufacturer. Write for free copy, see page 371. Requires 4 "AA" and two 9-v. batteries, sold on p. 404. 7 in. tall. For ages 4 years and up. 49 N 54584—Shpg. wt. 3 lbs. 8 oz... \$29.99

SAVE THIS CATALOG

THRU AUGUST 31, 1987

you can order any item on pages 375 thru 566... unless otherwise stated

ELECTRONIC space Toys



NOTE: Items (1), (3), (4) and (5) warranted by manufacturer. To write for free copy, see page 322.

(1) Milton Bradley's Big Trak™
Send Big Trak over lunar landscapes in search of moon monsters; then stun them with your laser. Program the Big Trak space vehicle to go forward, backward, turn left and right, rotate 360° and even fire laser guns! Big Trak can also be programmed for Big Trak Transport Trailer (not incl., sold below).
CONSTR: Plastic, metal, 13x8⁷/₈x6 in. high.
AGES, ORDER INFO: 8 years to adult. Requires 9-v. battery, 4 "D" batteries (not incl., order at right).
49 C 58289—Shpg. wt. 4 lbs. 11 oz. \$31.97

(2) Milton Bradley's Big Trak™ Transporter Trailer
Haul interstellar equipment in the Big Trak Transporter Trailer attached to the Big Trak (not included, sold above). Can be programmed by Big Trak to dump automatically.
CONSTR: Plastic, metal, 17⁵/₈x8³/₈x7 in. high.
FOR AGES, ORDER INFO: 8 years to adult. Requires "D" battery (not incl.; order package at right).
49 C 58287—Shpg. wt. 3 lbs. 11 oz. \$10.97

(3) Mattel's Sir Galaxy™ Radio Control Robot
Sir Galaxy walks, talks, turns right or left, flashes his eyes and makes cosmic sounds at your command! Hand-held radio control transmitter doubles as a walkie-talkie; lets you project your voice thru robot for two-way conversation.
CONSTRUCTION: Plastic, 14 inches tall. Arms pose; hands grasp objects.
AGES, ORD. INFO: 5 yrs. to adult. Requires 3 "D" batteries, two 9-v. batt. (not incl.; order at right).
49 C 58556—Shpg. wt. 5 lbs. 4 oz. \$64.97

(4) Playskool's Star Rider™ Space Vehicle
Star Rider has all the controls, switches, visual and sound effects to transport a child to the outermost galaxies. Child controls Star Rider completely; using volume control switch for sound control; flipping buttons for "rocket boosters," "laser weapon," "explosion hit," "warp drive," and "emergency." Star Rider pivots 360°, has comfortable "astronaut seat."
CONSTR: Plastic, 30³/₁₆x16¹/₂x20 in. high.
AGES, ORDER INFO: 3 to 9 yrs. Requires 2 "D" batteries, 9-v. battery (not incl.; order below). Partly assembled. Instructions incl. Astro Explorer Play Set shown on child is not included, order on page 621.
Shipping weight 16 pounds.
79 C 87239L \$49.88

(5) Parker Brothers ROM™ the Space Knight
ROM has micro-electronic circuitry that enables him to scan the area with lighted eyes, "breathe" realistically from his respirator and make lights flash and sounds with his Energy Analyzer. Includes 3 detachable electronic accessories with light and sound effects; Rocket Pods, Translator and Neutralizer.
CONSTRUCTION: Plastic with flexible joints. 14 inches tall.
FOR AGES, ORDER INFO: 6 yrs. and up. Requires 9-v. battery (not incl.; order below).
49 C 58121—Shpg. wt. 1 lb. 8 oz. \$18.97
DieHard Alkaline "D" Batteries, Package of 2.
49 C 46849—Shipping weight 10 oz. Pkg. \$1.59
DieHard Alkaline 9-volt Battery.
49 C 46859—Shipping weight 2 oz. ... Each \$1.49



No lower price in 1986



1 and 2 DON'T MAKE A MOVE UNTIL YOU CHECK OUT THESE COMPUTERIZED CHESS GAMES. So advanced they're recommended by the World Chess Champion, Garry Kasparov. Offer 17 levels of skill from beginning to advanced tournament play. The sensory surface automatically records your moves and illuminates countermoves. Long-term memory stores interrupted games for up to two years. Unique "display move" mode allows opponent to see what the computer is thinking. Magnetic surface and pieces. Warranted by manufacturer, write for free copy, see page 371. Batteries sold separately on pg. 404. For ages 12 yrs. to adult.

The digital clocks on the full-sized Turbo 16K makes timing your moves a breeze. Clocks start automatically whenever the chess board is activated. Carrying case is included for convenient travel. Requires 4 "C" batteries. 49 N 65553—Wt. 3 lbs. 14 oz. . . \$99.99

2 This portable Express 16K game is easy to store and carry. Requires 3 "AA" batteries. 49 N 65552—Wt. 1 lb. 2 oz. . . \$79.99

3 and 4 PLAY LIKE A CHAMP with these computerized games. Recommended by Garry Kasparov, the World Chess Champion. Sensory board automatically reads your moves. Computer acts as referee between 2 human players. "Take back" mode allows change in strategy. Long-term memory. For 1 or 2 players. Needs 3 "AA" batteries, sold on p. 404. Warranted by manufacturer, write for free copy, see pg. 371.

3 Fun for the entire family. The award-winning Electronic Trio is 3 games in 1. 8 skill levels of chess and checkers. 4 levels of tic-tac-toe. Ages 7 years and up. 49 N 65551—Wt. 1 lb. 4 oz. . . \$49.99

4 Travel Mate II Chess game has 8 levels of play. Dust cover included. 49 N 65550—Wt. 1 lb. 2 oz. . . \$29.99

5 TAKE-ALONG FUN WITH THIS BACKGAMMON SET! Incl. padded vinyl case. Cotton felt playing board has stitched points. Imported. For 2 to 4 players ages 8 yrs. to adult. 49 N 61348—Wt. 3 lbs. 6 oz. . . Set \$9.99

SAVE THIS CATALOG

THRU AUGUST 31, 1987
you can order any item on pages
375 thru 566... unless otherwise stated

**CELEBRATING SEARS
NEW CENTURY**



10-Yard Fight™
49 N 65907 ... \$29.99



1943™
49 N 65867 ... \$34.99



3-D World Runner™
(w/glasses)
49 N 65954 ... \$34.99



Adventures of
Bayou Billy
49 N 65981 ... \$44.99



Bases Loaded™ baseball
49 N 65837 ... \$44.99



Bionic Commando™
49 N 64793 ... \$39.99



Commando™
49 N 64781 ... \$29.99



Contra™
49 N 65833 ... \$34.99



Deadly Towers™
49 N 65512 ... \$34.99



Double Dribble
49 N 65888 ... \$34.99



Excitebike®
49 N 65913 ... \$34.99



Goonies II™™
49 N 65846 ... \$34.99



Gotcha™ (Zapper gun)
49 N 65899 ... \$39.99



Gun Smoke™
49 N 65825 ... \$34.99



Hogan's Alley®
(Zapper gun)
49 N 65910 ... \$34.99



©1986 Nintendo

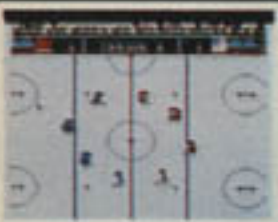

Ice Hockey
49 N 65952 ... \$39.99



Karate Kid™™™
49 N 64795 ... \$39.99



Kid Niki™
49 N 65673 ... \$44.99

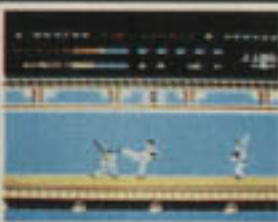

Kung Fu®™™
49 N 65905 ... \$29.99



©1986
Nintendo

YOU DON'T NEED TO Here's the largest assortment of

That's right! We have the biggest inventory of the most popular games available ... best-sellers like *Legend of Zelda™* and *Mike Tyson's Punchout!!®*, and even new titles like *Zelda II—the Adventure of Link™*.

Now you're playing



Life Force
49 N 65976 ... \$34.99



R.B.I. Baseball®
49 N 65848 ... \$44.99



Metal Gear
49 N 64784 ... \$34.99



Metroid™
49 N 65922 ... \$34.99



Mickey Mouse®
49 N 65508 ... \$44.99



Mike Tyson's
Punchout!!®
49 N 64778 ... \$34.99



Rambo®†
49 N 65963 ... \$34.99



Rampage™
49 N 65692 ... \$44.99



Ring King™
49 N 65838 ... \$34.99



Section Z™
49 N 64787 ... \$34.99



Side Pocket™
49 N 65674 ... \$34.99



T & C Wood and
Water Race™
49 N 65863 ... \$39.99



Tag Team Wrestling™
49 N 65504 ... \$29.99



Tennis
49 N 65908 ... \$29.99



Tiger Heat®
49 N 65958 ... \$34.99



Top Gun®†
49 N 64799 ... \$34.99

Big games, Big movies, Big stars, Big news... Big reasons for owning Sears Big Screen TV



WISH BOOK VALUE

Command a quartz precision-tuned Color TV from your favorite chair... an 18-button deluxe remote control puts you in charge, plus Comb Filter gives a 20% sharper picture than TV's without

Cut \$180
\$799⁹⁵



The solid look of oak makes this 25-inch remote control color TV the center of attention

Save \$100 **\$619⁹⁵**

(1 thru 3) If the screen is big, the picture better be great... and our In-line Super Chromix® black matrix picture tube with pigmented filtered phosphors helps assure vivid, natural colors. Plus, set the right color and keep it with One-button color and individual controls for color, tint, contrast and brightness. Channel Touch selector (except (1)) lets you receive up to 105 channels incl. cable* by touching any two-digit combination. LED channel readout. Remote uses batteries, incl. Imported parts; assembled in the USA. 7-ft. cord. See NOTE below.

WISH BOOK VALUE

You'll see 4 times more picture on this 50-inch projection TV

Cut \$700
\$1695⁰⁰



(1) Handsome oak-veneer finish with cross-hatch design will look great in your living room. And you can rely on the electronic tuner to provide a consistently good 25-inch diagonal measure color picture. Sensor-Scan 3-button remote control channel selector scans up or down any 12 pre-set channels at the touch of a finger... lift finger to stop scan. Set-and-forget volume control. 34½Wx28¼Hx20¼D in. 5-inch round speaker. Was \$719.95 in our 1982 Fall Big Book, page 875.

Shipping weight 155 pounds.
57 E 4901N **\$619.95**

(2) Get lifelike color fidelity on your 25-in. diagonal measure TV screen thanks to VIR+ Color Control that automatically corrects color, tint 60 times per second. And when VIR+ is not active, an auto. back-up color system takes over. A light sensor adjusts picture to room light conditions. Twin electronic pushbutton volume controls. Simulated wood with pecan-look grained top, sides. Casters. 40¼Wx30¼Hx20¼D in. Audio output jack. Two 5-in. cone shaped speakers. Was \$979.95 in our 1983 Spring Big Book, p. 699.

57 E 4995N—Shpg. wt. 169 lbs. ... **\$799.95**

(3) When we say big, we mean big! A 50-in. diag. measure screen turns your living room into a movie theatre. The picture is terrific because a Comb filter provides a 20% sharper picture than TV's without. Plus there's sharpness control and twin electronic pushbutton volume controls. So sit back and watch giant screen action; a handy 16-button remote control lets you change channels, adjust volume, get LED channel readout, turn set on/off all without getting up. You can mute sound if phone rings. Speaking of sound... it's big, too: 5-w. min. RMS. Dual 5-in. speakers, dual 2-in. tweeters. Tuner is quartz, for precision. Handsome walnut-look cabinet has a video systems shelf, fold-down mirror. Washable screen. 31½x42½ in. wide. 41¼Wx58¼Hx42D in. closed. 30¼D in. open. Casters. AC outlet for VCR or Video disc player. Screen sent detached. Was \$2395.00 in 1983 Fall Big Book, p. 858.

57 E 5440N—Shipping weight 187 lbs. **\$1695.00**
*Check with your local cable company.



4 Sears Stereo Video Disc Player is a box office in a box and we start you off with a double feature

\$299⁹⁹

(4) We'll start your video disc collection off right with two great hits: On Golden Pond and Disney Cartoon Parade Volume IV—a \$49.98 value... all for only \$10 more than our 1983 Fall Big Book Video disc player price! Find your favorite part of the movie quickly with 2-speed visual search. Handy semi-automatic loading. Plays both stereo and mono CED-format discs. Direct drive and CX noise reduction system for smooth sounding movies. Auto. return at end of disc; mid-disc return button. Pause control. 4¼Hx16¼Wx16¼D in. Auto. antenna switch. Audio/video output jacks. Antenna in/out. 6-ft. cord. See NOTE below. See our 1983 Fall Big Bk., for a complete list of video discs available.

C 57 E 54819N—Shipping weight 24 pounds **\$299.99**

NOTE: UL listed for AC. See 1983 Fall Big Bk. for Sears specific written warranty or write for free copy, p. 323. "N" suffix note, p. 323. Simulated reception for all TV's on both pages.

It's Game, Set, and Match with Exciting Screen Tennis!

Only
28⁹⁹

- Compact, portable table-top game lets you enjoy the sport anywhere in any weather

TURN IT ON and the "ball" (blip light) starts moving across the screen. Turn the dial and your "racket" moves across your end line to return your opponent's volleys. When the ball hits the end line, the score board automatically indicates a point. The first person to make his opponent miss the ball 11 times wins the game. Counterdial resets scoreboards. Operates on 4 "D" cell batteries—not included, order batteries on page 293. Molded plastic. 19½x10½x3 in. high. X 641-6390 A—Mailing weight 5.50 lbs. 28.99



Money "Darts"

- All the fun of darts with none of the risks

5⁹⁹

TOSS AND SCORE with Velcro® "plus" and "minus" cubes. 15x17 in. foam-backed plush fabric target has denominations silk-screened on surface. Instructions included for high-low, exacto, jack-pot, and bust-the-bank—or make up your own games. For any number of players. Mailing weight 0.70 lb. X 641-6374 A 5.99



An Old Favorite Takes a Turn for the Better with Turntable Tripoley®

12⁴⁹

DELUXE VERSION of the popular game. Combines poker, hearts, and Michigan rummy. Ball-bearing, high-impact styrene turntable with slide- and scratch-resistant bottom has storage space for chips. 200 chips, cards, instructions included. For 2 to 9 players. Measures 14½x14½x2½ in. Mailing weight 3.25 lbs. X 641-6358 A 12.49

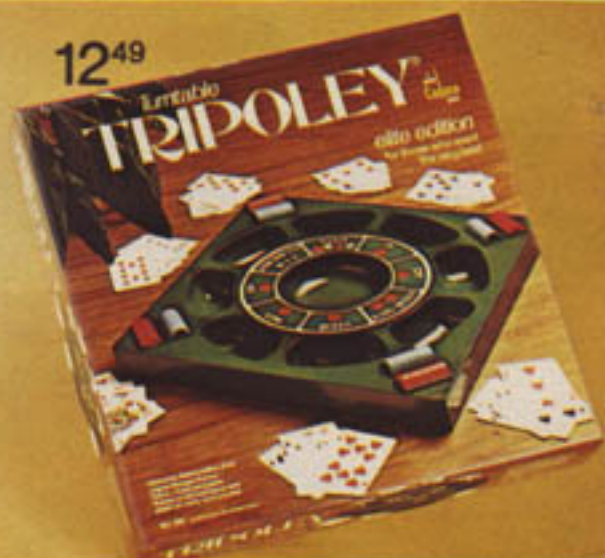

1 7⁹⁹

Tall Ship War Game puts you in command of the fleet as you try to out-manuever your opponents!

Set Sail for Adventure with Wooden Ships and Iron Men®

1 CHOOSE A SINGLE BATTLE SCENARIO and fight a ship-to-ship duel or link up the 5 scenarios and fight a week long series of engagements. Includes multi-player rules, advanced game tables, ship's log pad, one die, set of die-cut counters, and 2-section map board (44x56 in. overall, opened; 11x14 in. closed). X 641-6408 A—Mailing weight 3 lbs. 7.99 ©1975 The Avalon Hill Game Company

Includes equipment and complete instructions for 12 games of chance

2 8⁹⁹

A Sure Bet for Fun— Weekend in Vegas®

2 LETS YOU PLAY black jack, stud poker, dice, roulette, slot machine, banker/broker, state lottery, horse racing, and 4 more plus 10 different real estate speculations. Includes casino game board, 3 dice, 150 poker chips, standard deck of playing cards, roulette wheel spinner, 6 sleek race horses, 10 business ownership cards, 6 player markers, 96 lottery tickets, 16 para-mutuel odds cards, 2 pool and bank trays, play checks, and complete instructions. X 641-6416 A—Mailing weight 2.50 lbs. 8.99



3 POKER CHIP RACK. Rich-looking, ebony finish plastic with clear plastic cover. Cover converts to base when in use for a handy revolving rack. Includes 100 interlocking red, white, and blue plastic chips. Measures 4 in. diameter x 4 in. high. X 641-6382 A—Mailing weight 3 lbs. 3.49

3

Revolving
Chip
Rack
3⁴⁹



4 WALNUT DOMINOES. Complete set of double-six dominoes in attractive brown walnut with deeply-etched, gold-color dots. Solid walnut storage case with green felt lining. Clear-acrylic sliding cover. 5x5x2¼ in. high. X 641-6366 A—Mailing weight 1.50 lbs. . . . 9.49

4

Deluxe
Domino
Set **9⁴⁹**



Charge It—see page 334

SAVE \$20

Only Till December 27, 1980

on ATARI®

Video Games System

NOW ONLY **144.95**
Charge it—
see page 363

After Dec. 27, Order at Reg. Price

Atari® Video Computer System. Vivid colors, sharply defined characters, and realistic sounds all add to the excitement of the challenging games you can play. Programmable console unit allows up to 112 game variations from 1 game cartridge. 2 pairs of controls included; paddle controllers and joystick controllers. Also includes Combat cartridge. Attaches to external VHF antenna leads on TV. Games appear in color on color TV's only. Plastic housing. 23½ x 13 x 4½ in. high. 110-120 V, AC, UL listed. Reduced from our big Spring '80 Catalog.

Operates on non-receiving Channel 2 or 3. Del. wt. 9.50 lbs.

X 917-3089 A Reg. \$164.95; NOW 144.95

Extra Paddle Controllers for cartridges marked with an Asterisk (*) on this page. Allows you to play with 2 additional people. Del. wt. 1.20 lbs.

X 917-2602 A 19.95

SAVE 10%

When You Buy

2 or More Cartridges

Atari Game Cartridges. Delivery weight 0.50 lb.

Space Invaders. Destroy creatures from outer space before they can land on earth.

X 640-2614 A.....Each 29.95; 2 or more Each 26.95

Home Run. Try to pitch a no-hitter.

X 917-3246 A.....Each 21.95; 2 or more Each 19.75

Breakout.* 48 ways to escape through a wall.

X 917-3196 A.....Each 21.95; 2 or more Each 19.75

Outlaw. Become an Old West Gunslinger.

X 917-3188 A.....Each 21.95; 2 or more Each 19.75

Air/Sea Battle. 27 different target practice games.

X 917-2545 A.....Each 21.95; 2 or more Each 19.75

Street Racer.* Race against time & obstacles.

X 917-2552 A.....Each 21.95; 2 or more Each 19.75

Night Driver. Try driving along a winding road at night without crashing!

X 640-2606 A.....Each 21.95; 2 or more Each 19.75

Video Olympics.* 50 games. Hockey, Pong, etc.

X 917-2560 A.....Each 21.95; 2 or more Each 19.75

Football. 3 variations. Play offense; defense.

X 917-3600 A.....Each 21.95; 2 or more Each 19.75

Bowling. 6 variations. For 1, 2 players.

X 917-3618 A.....Each 21.95; 2 or more Each 19.75

Circus. Test your reflexes. Pop all the balloons by bouncing the clown on the teeter-totter.

X 640-2622 A.....Each 21.95; 2 or more Each 19.75

3D Tic-Tac-Toe. Play on 4 boards at once!

X 640-2648 A.....Each 21.95; 2 or more Each 19.75

Golf. Watch out for water and sand traps!

X 640-2630 A.....Each 21.95; 2 or more Each 19.75

Superman (©DC Comics, Inc. 1979). Avoid Satellites; capture Lex Luther.

X 917-3626 A.....Each 29.95; 2 or more Each 26.95

Basketball. 1-on-1 action against the clock.

X 917-3261 A.....Each 21.95; 2 or more Each 19.75

Chess. It's you against the computer!

X 917-3584 A.....Each 39.95; 2 or more Each 35.95

Backgammon. Several versions. Play the computer or another player.

X 917-3592 A.....Each 39.95; 2 or more Each 35.95



CONSUMER INFORMATION ABOUT ELECTRONIC GAMES

Today's new computer electronic games are an exciting and entertaining way to introduce a child to modern technology. Games are available for all age levels, so you can match the game's complexity with the child's skills. Games that plug into the TV set offer large, easier-to-read display screens; many are programmed for a variety of games.

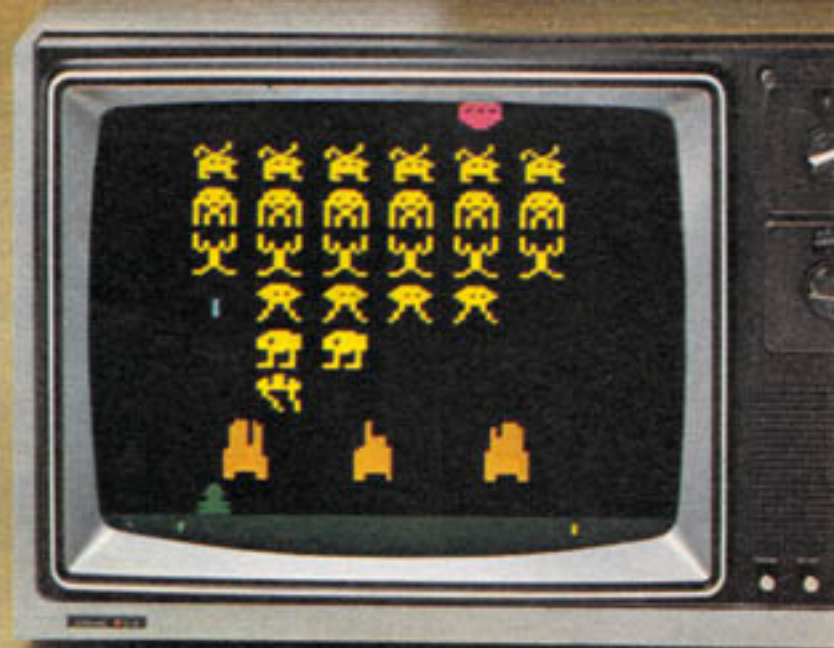

Space Invaders shown on TV screen

TV not included

Joystick controls



Paddle controls

Build Your Own Entertainment Library with Exciting Atari® Game Cartridges



Home Run



Breakout



Outlaw



Air-Sea Battle



Street Racer



Night Driver



Video Olympics



Football



Bowling



Circus Atari



3D Tic-Tac-Toe



Golf



Superman®



Basketball



Video Chess



Backgammon



26-in. Squareview color TVs
with built-in stereo

Save \$300

Now **\$879⁹⁹**

A and B. For \$32 monthly*, our finest console TVs feature full stereo† sound and a 26-in. diagonal measure screen. Twin amplifiers, 4 speakers and double baffle design provide a balanced sound; or you can listen to programs broadcast in a 2nd language. 21-button Channel Touch remote control tunes in up to 140 cable-compatible channels with quartz precision. Shielded cable connector. Comb filter gives 20% sharper picture than TVs without it. Lock out 2 cable channels to prevent children from viewing. Off-timer. Light sensor. 1-button color, plus individual controls. On-screen time and channel display fades after 5 seconds. See Note on facing pg. Each was \$1179.99 in our 1985 Fall Big Book, page 1089.

A. Early American. Simulated pine finish. 46Wx35Hx22D-in. cabinet. 57 E 4876N—Wt. 190 lbs. . . **\$879.99**

B. Transitional. Simulated hickory finish. 46Wx31Hx22D-in. cabinet. 57 E 4886N—Wt. 178 lbs. . . **\$879.99**

† Only in areas and at times when programs are broadcast in stereo or a 2nd language. Consult your local listings.

Sears Best



OUR LOWEST PRICE EVER

for big-screen viewing on
this 50-in. projection TV

Save \$700 \$1279

C. \$46 monthly* puts you on the 50-yr. line for the big game with this 50-in. diagonal measure picture, handsomely styled in a cabinet that takes less than 9 sq. ft. of floor space! Lens system rejects dust; comb filter delivers a 20% sharper picture than TVs without it. One-button color adjusts picture instantly, or use individual controls for minor adjustments. 16-button Channel Touch remote tunes in up to 105 cable-compatible channels with a simple 2-key command and quartz-precision accuracy. 2 big speakers have bass and treble controls. And this set needs no cooling fan, so no noise disturbs the quiet scenes. Washable 32x43-in. wide screen.

Simulated walnut cabinet has video system shelf, fold-down mirror. AC outlet accommodates a VCR or VDP. Unit is 42Wx59Hx31D in. closed; 42D inches open. 4 casters. Screen sent detached.

See Note on facing page. Was \$1979.00 in our 1985 Spring Big Book, page 926.

57 E 5440N—Shipping weight 187 pounds. . . **\$1279.00**

*See page 338.





COLECO



Soccer



Hockey



Basketball



MATTEL



Sports Illustrated



- You control ball direction, curve, speed and release
- Hint feature shows best ball path
- Real bowling scoring for up to 4 players

COLECO



- 1 or 2 players
- Digital display—10 round scoring
- 4-direction joy stick control
- Automatic skill adjustment

REBATE
 Wards low price **32⁷⁷**
SAVE \$10
 when purchased with Ray-O-Vac batteries... see how at right.

A Total Control 4™... electronic football game. Allows up to 4 people to play head to head. FEATURES: Four direction joy stick. Run plays right out of play book (incl.). Trap, draw and misdirection plays. LED action and statistics display. Snap in basketball, hockey or soccer cartridges (sold separately below) for more action. Football cartridge incl. Uses two 9-volt batteries.* AGES: 8 and up. 48 T 14442—Ship. wt. 15 oz. 48.88

3 CARTRIDGES FOR TOTAL CONTROL 4 (A) above. Includes Basketball, Hockey and Soccer. 48 T 14443—Ship. wt. 15 oz. set 14.99

B World Championship™ electronic football. FEATURES: Players are actual shaped figures. Choose from 5 formations, call unlimited number of plays or run in for a touchdown. Make pass interceptions, blitz your safety. "Charge" tune announces kickoff and touchdowns. 4 speeds. Separate controls for each team. Uses 6 "C" batteries.* 48 T 14444—AGES: 8 up, Wt. 6 oz. 69.88

C Title Bout... recreate great ring match-ups! FEATURES: Championship boxing with over 400 past and present boxers. Ages 12 and up. 48 T 14210—Ship. wt. 2 lbs. 8 oz. 14.99

D Paydirt... a new board game authenticated for accuracy by Sports Illustrated game staff. FEATURES: Coach actual NFL-AFL teams that are calibrated to perform as they do in real life. 48 T 14207—12 yrs. and up. Wt. 2 lbs. 8 oz. . 14.99

E Bowlatronic™... electronic bowling game. FEATURES: Keep an eye on Pro-bowler—the LED figure. As he makes his approach, get ready. When he reaches the speed you want and releases his ball, release yours. LED scoring, bowling sounds. Uses two 9V batteries.* AGES 8 and up. 48 T 14453—Ship. wt. 1 lb. 3 oz. 32.77

*Batteries not included; order on page 380.

F Digital Diamond™ pushbutton baseball. FEATURES: It's player against player. The pitcher can throw a fastball or curve. The batter can strike out, hit single, double, triple or home run. Digital scoring. Uses 2 "AA" batteries.* 48 T 14528—AGES: 6 and up, Wt. 1 lb. 10.77

G NFL Strategy football—professional game. FEATURES: Precisely designed to give 40 offensive and 12 defensive plays. Automatic timer with 2-minute option. Big 44-page confidential play book by NFL staff. AGES: 8 and up. 48 T 14314—Ship. wt. 2 lbs. 8 oz. 18.76

H Head to Head™ electronic boxing. FEATURES: Turn game on and traditional Gillette "Look Sharp" song plays. Boxers move to ring center, touch gloves, bell rings, fight begins. You punch—he blocks. You slam with a hard right... knockout! Working LED referee, boxing sounds. Uses one 9V battery.* AGES 8 and up. See below for info. on how to save \$10 when purchased with Ray-O-Vac batteries. 48 T 14454—Ship. wt. 12 oz. 32.77

HOW TO GET YOUR MANUFACTURER'S REBATE. Purchase any 2 packages of Ray-O-Vac alkaline batteries on pg. 483. Write to address below for official certificate. Include the following in an envelope and mail to the address shown below: (1) Proof of purchase seal (or 2 end panels) from Coleco game; (2) Cut the top ¼ of the 2 battery packages; (3) A copy of your dated sales slip (dated between 9/15/81 and 12/31/81); (4) Official mail-in certificate; (5) Please PRINT on a separate piece of paper your name, address and zip code. MAIL TO: Coleco-Ray-O-Vac Refund Offer, P.O. Box 6678, Maple Plain, MN, 55348. You will receive a check for \$5 and \$5 worth of refund certificates redeemable on Ray-O-Vac battery purchases. Offer ends Dec. 31, 1981. Coupon must be POST-MARKED BY DEC. 31, 1981. This offer is good only in the U.S.A. and is void where prohibited, taxed or restricted by law. Allow 6 weeks for delivery. One refund per household, address or organization.

Just in time for Christmas stocking stuffers... Atari 2600 and Intellivision game cartridges at great savings. Some as low as 3.99. But hurry... only a limited number are left and when we're out, we're out!

Game cartridges for Intellivision by Mattel

Title*	Players	Catalog number	Ship. wt.	Price each
Mouse Trap	1 or 2	62 G 43643	9 oz.	9.99
Nova Blast	1 or 2	62 G 45405	9 oz.	9.99
Black Jack	1 or 2	62 G 45602	9 oz.	3.99
Checkers	1 or 2	62 G 45610	9 oz.	3.99
Backgammon	1 or 2	62 G 45650	9 oz.	3.99
Royal Dealer	1 or 2	62 G 45652	9 oz.	3.99
Hockey	1 or 2	62 G 45700	9 oz.	3.99
Soccer	1 or 2	62 G 45702	9 oz.	3.99
Golf	1 or 2	62 G 45704	9 oz.	3.99
Armor Battle	1 or 2	62 G 45751	9 oz.	3.99
Vectron	1 or 2	62 G 45753	9 oz.	9.99
Football	1 or 2	62 G 45754	9 oz.	9.99
Space Battle	1 or 2	62 G 45755	9 oz.	3.99
Baseball	1 or 2	62 G 45756	9 oz.	9.99
Sub Hunt	1 or 2	62 G 45759	9 oz.	9.99
Space Armada	1 or 2	62 G 45762	9 oz.	9.99
Tron Deadly Disc	1 or 2	62 G 45763	9 oz.	9.99
Tron Mazatron	1 or 2	62 G 45764	9 oz.	9.99
Dungeons & Dragons	1 or 2	62 G 45800	9 oz.	9.99
Space Hawk	1 or 2	62 G 45801	9 oz.	9.99
Utopia	1 or 2	62 G 45802	9 oz.	3.99
Star Strike	1 or 2	62 G 45803	9 oz.	9.99
Night Stalker	1 or 2	62 G 45804	9 oz.	9.99
Burger Time	1 or 2	62 G 45806	9 oz.	14.99
Dungeons & Dragons Treasure of Tarmin	1 or 2	62 G 45808	9 oz.	14.99
Roulette	1 or 2	62 G 49551	9 oz.	3.99
Chess	1 or 2	62 G 49557	9 oz.	14.99
Frog Bog	1 or 2	62 G 49552	9 oz.	3.99

Game cartridges for Atari 2600

Title*	Players	Catalog number	Ship. wt.	Price each
Games by Atari for Atari 2600 console				
Tic Tac Toe	1 or 2	62 G 43205	9 oz.	3.99
Pele's Soccer	1 or 2	62 G 43207	9 oz.	3.99
Sky Diver	1 or 2	62 G 43224	9 oz.	3.99
Bowling	1 or 2	62 G 43228	9 oz.	3.99
Baseball	1 or 2	62 G 43259	9 oz.	4.99
Football	1 or 2	62 G 43260	9 oz.	4.99
Missile Command	1 or 2	62 G 43272	9 oz.	4.99
Tennis	1 or 2	62 G 43285	9 oz.	4.99
Asteroids	1 or 2	62 G 43293	9 oz.	4.99
Joust	1 or 2	62 G 43318	9 oz.	9.99
Games by Activision for Atari 2600 console				
Kaboom	1 or 2	62 G 42817	9 oz.	9.99
Bridge	1 or 2	62 G 42839	9 oz.	9.99
Megamania	1 or 2	62 G 42842	9 oz.	9.99
Oink	1 or 2	62 G 42846	9 oz.	9.99
Robotank	1 or 2	62 G 42850	9 oz.	9.99
Games by Parker Brothers for Atari 2600 console				
Amidar	1 or 2	62 G 46402	9 oz.	14.99
Super Cobra	1 or 2	62 G 46404	9 oz.	14.99
Tutankahm	1 or 2	62 G 46406	9 oz.	14.99
Popeye	1 or 2	62 G 46511	9 oz.	14.99
Games by Bix Video for Atari 2600 console				
Alien	1 or 2	62 G 44412	9 oz.	4.99
Mega Force	1 or 2	62 G 44413	9 oz.	4.99
Turmoil	1 or 2	62 G 44417	9 oz.	4.99
Worm War I	1 or 2	62 G 49123	9 oz.	4.99
Games by Imagic for Atari 2600 console				
Cosmic Ark	1 or 2	62 G 45213	9 oz.	4.99
No Escape	1 or 2	62 G 45216	9 oz.	4.99
Shooting Gallery	1 or 2	62 G 45218	9 oz.	4.99
Games by CBS for Atari 2600 console				
Tunnel Runner	1 or 2	62 G 44803	9 oz.	4.99
Games by Coleco for Atari 2600 console				
Carnival	1 or 2	62 G 43807	9 oz.	9.99

*Write for a free copy of Manufacturer's Warranty, see page 497.

More entertaining video game cartridges for use with Atari 2600 console on page 534. Plus, some of today's most popular Atari 5200 game cartridges on page 535.

See the Atari 2600 video game console, joysticks and paddles on page 535.

See page 531 for video game storage centers and video game cartridge storage cabinets.

ColecoVision video game console, accessories and game cartridge can be found on page 532.



Dungeons & Dragons



Vectron

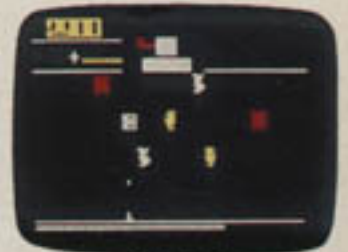

Carnival



Baseball



Popeye



Tutankahm



Tunnel Runner



Robotank



1. Talk 'n Play cassette player/recorder learning set features a friendly, pre-recorded voice that coordinates with the workbook to ask a question; your child responds by pushing the brightly colored buttons. "Can you find your way to Sesame St.?" program included. Requires 4 "D" batteries, sold separately on p. 459. Warranted by CBS Toys.** For ages 3½ and up. Wt. 5 lbs. 8 oz. 49 C 17752...\$58.99

2 thru 6. Additional cassette and booklet sets for Talk 'n Play (1). 2 booklets per set.

2. Space Shuttle Adventure; Fairytales. 49C17795-Wt. 12 oz. ... Set \$12.99

3. Dinosaurs; Space Adventure. 49C17794-Wt. 12 oz. ... Set \$12.99

4. Reading Robot; Jokes, Riddles and Gags. 49C17793-Wt. 12 oz. ... Set \$12.99

5. Mother Goose; Three Little Pigs. 49C17791-Wt. 12 oz. ... Set \$12.99

6. Funny Old Grover; Baby Animals. 49C17792-Wt. 12 oz. ... Set \$12.99

7. Learning is fast and fun with the Little Professor™ II. Your child can sharpen math skills on 4 levels of play, with 2 chances to answer before correct answer is displayed. Correct answers get a smile from the professor and a star on the screen. Automatic shut-off after 2 minutes of non-use. Requires 2 "AA" batteries sold separately on p. 459. Warranted by Texas Instruments.** For ages 5 and up. 49 C 17604—Shipping weight 9 ounces...\$11.99

8. The Cookie Counter from Fisher Price® is perfect for introducing your preschooler to math. There are 6 activities including adding, subtracting and juggle games to entertain your child for hours. Automatically shuts off after a couple of minutes of non-use. Requires 2 "AA" batteries, not included, sold on p. 459. Warranted by Fisher Price.** \$23.99 after rebate from Fisher Price, see details on p. 186 of our 1985 Christmas Book. For ages 3 years and up. 49 C 17617—Shpg. wt. 1 lb. 2 oz. ... Full price alone \$28.99

9. Casey is a special friend your preschooler will love. He's a cassette player that tells a story as your child reads along. Casey looks like he's reading too! His expressive, animated face lip syncs while the tape plays. 3-second pauses in the tape automatically shut Casey off, allowing your child to comprehend and respond at his or her own pace. Push Casey's "go" tie to reactivate him. Tapes store in his handy backpack. Warranted by Playskool.** Requires 4 "D" batteries, not included, see page 459. Order additional tapes below. For ages 3 years and up. 49 C 17635—Shipping weight 2 lbs. 8 oz. ...\$58.99

"Seashore Adventure" cassette/book set for Casey. 49 C 17636—Shipping weight 8 ounces...\$7.99

"Color Surprise" cassette/book set for Casey. 49 C 17637—Shipping weight 8 ounces...\$7.99

"Gingerbread Man" cassette/book set for Casey. 49 C 17638—Shipping weight 8 ounces...\$7.99

10. Alphie II teaches children math, spelling, colors and problem solving. He provides music for a sing-along or a game of musical chairs. 4 two-sided activity cards provide loads of things to do. Additional activity sets sold below. Requires 4 "AA" batteries sold separately on p. 459. Warranted by Playskool.** For ages 3 to 8 years. 49 C 17631—Shipping weight 2 pounds 8 ounces...\$24.99

Package of 2 activity sets for Alphie II (not shown). Provide lessons for overlapping age levels. With 4 double-sided activity cards, game board and playing pieces. You get "basic Numbers & Shapes" for ages 3 to 5 years and "Get Ready to Read" for ages 4 to 6 years. 49 C 17632—Shipping weight 1 pound...Pkg. \$9.49

11. Vinyl case is perfect for carrying cassettes for Casey, Talk 'n Play and other cassette/book sets. 15¼x9¼x3¼-in. case holds up to 16 loose cassettes or 8 boxed cassettes. For ages 5 and up. 49 C 17649—Shipping weight 2 lbs. 8 oz. ...\$6.99

*Trademark Children's Television Workshop
**Write for free copy, see page 335



\$5 REBATE
when you also buy \$15 in F. P. playwear on p. 186 of Wish Book



DELUXE VIDEO GAME from

APF

SAVE \$80

APF 1000

\$99



02—Hangman



15—UFO



16—Pinball



13—Space Destroyers



09—Baseball



04—Bowling



03—Brickdown



18—Boxing

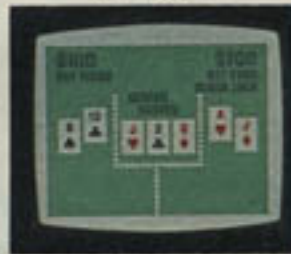

11—Blackjack



17—Roulette



19—Backgammon



08—Capture

The APF 1000 video game provides all the sounds and sights of the popular commercial arcade games—right in your own home! This sophisticated unit can accept an infinite number of game cartridges. You get one exciting Rocket Patrol game built-in!

FEATURES: High impact plastic console with scoring system. Two remote hand controls can be used away from console deck. Keyboard entry, joy stick for lateral or vertical movement, firing button. Operates on any color or black and white TV set. Just turn the game off to get normal TV reception (game will not alter TV picture in any way.) Comes with AC adapter. Was \$179.00 in '81 Fall Book, pg. 662.

60 T 95070—Mfr.'s Warranty.* Wt. 5 lbs. . now **99.00**

USE THIS CAT. NO. TO ORDER ALL APF GAMES ON THIS PAGE EXCEPT SPACE DESTROYERS.

State code number.

Z 60 T 95071—Ship. wt. 3 oz. ea. **22.95**

02—Hangman, Tic-Tac-Toe, Doodle. Two competitive games, plus the electronic art of Doodle. 1 to 4 players.

03—Brickdown, Shooting Gallery. It takes smart shooting to get all the bricks, and a steady aim. 1 or 2 players.

04—Bowling, Micro-Matchup. Based on odds from lane bowling, this electronic bowling game has three separate variations. Micro-Matchup tests your memory for words, colors and shapes, like "Concentration"! 5 variations. 1 to 4 players.

08—Capture. Plays like the popular game "Othello." A game of decisive strategy with 3 variations. 2 players.

09—Baseball. The great American pastime can still be great—even when the weather isn't. 2 players.

11—Blackjack. Great practice! You'll really clean up at the real thing! Smart decisions, not always luck, determine if you beat the machine. 1 or 2 players.

15—UFO, Shoot-a-Lot, Sea Monsters, Break-It-Down. Two great adventures in space and the deep, and two challenging carnival games. 1 or 2 players.

16—Pinball, Blockout, Dungeon Hunt. Electronic flippers and tricky ball speed changes in pinball. In Dungeon, search and score. 1 or 2 players.

17—Roulette, Keno, Slot Machine. All games are played by the real Las Vegas rules. Even has the authentic sounds of the casino, too! 1 or 2 players.

18—Boxing. Features 2 boxers battling toe to toe like Dempsey and Firpol 6 variations. 1 or 2 players.

19—Backgammon. This ancient game has never been more popular—and it really comes to life in all the colors of your TV screen. 2 players.

13—Space Destroyers. You'd better think fast if you're going to beat the deadly interstellar robot destroyers—they don't give up! 1 player.

Z 60 T 95073—State code no. 13. Wt. 3 oz. . . . **37.95**

On target with Coleco Telstar Marksman

• Photo electric rifle for Skeet and Target games

• Plus 4 exciting video games for family enjoyment

32⁵⁰

This is a Christmas family gift idea that hits the bulls eye! You get two challenging pistol games: a moving, darting object to be hit in the Target game, and in the Skeet game, you get one shot as it streaks across the screen. Plus 4 popular sports games—Tennis, Hockey, Handball and Jai Alai. Marksman photo electric rifle can be used as a regular pistol, a machine gun, or a marksman rifle. Features on-screen digital display scoring, electronic sound effects and variable skill control. Operates on any color or black and white TV (will never interfere with reception.) Uses two 9-volt batteries (not included, see pg. 380.) Manufacturer's Warranty.*

60 T 95004—Ship. wt. 5 lbs. **32.50**



ALL WARDS 375

Digital audio is awesome

Sound so clear, you can't believe your ears the first time you listen to a disc... or the one thousandth time

You've heard stereo before, but never like this. Treat your ears to music that sounds so real, you might just think it's the original. Our Compact Digital Audio Disc Player (CD) uses a sophisticated laser system to delicately lift the sound off compact discs for phenomenal sound.

No snaps, crackles or pops

Out of the silence comes full, dynamic stereo so clean and clear, it's virtually uncompromised by background noise. In fact, our CD delivers sound with wow and flutter so low, it's undetectable.

It's easy to operate

All you do is push the "open" button and the drawer slides out. Drop in a disc, push the button again to close drawer, hit play and you're ready for great music. You can also program the songs in any order you want.

Great sound for years to come

These discs are practically indestructible. You no longer have to worry about dust and dirt, fingerprints or even warping thanks to their tough plastic coating.

We'll even start your disc library

You'll get Vivaldi's *The Four Seasons*, Handel's *The Water Music* and Tchaikovsky's *Symphony #5* all for only \$10 more



Compact Digital Audio Disc Player **\$589⁹⁹**

You'll enjoy up to 60 minutes of the best sound recordings you've ever heard on just one side of the disc. Since the disc rotates at a rate of 200 to 500 times per minute, we've added a special direct-drive motor that will play your discs at these high speeds. Plugs into stereo's aux. or tape jacks. For all dedicated audiophiles, here are vital specs. Each disc is only 4 1/4 in. in diam. (actual size shown above). The frequency response is 5 Hz. to 20 KHz. Dynamic range, signal to noise ratio and channel separation are 90 dB or more. THD is 0.003% (1 KHz.). Plastic cabinet, only 3 1/2 H x 13 1/4 W x 12 1/2 D in. See Note, p. 409.

57 E 9750C—Shpg. wt. 16 lbs. Compact Disc Player alone **\$589.99**

408 ALL For \$10 more you get 3 discs (mentioned above) with your Player
57 E 97509C—Wt. 17 lbs. Player with 3 discs **\$599.99**

EVERYTHING YOU EVER/NEVER WANTED TO KNOW ABOUT LASERS

A laser sounds boring until you hear it work. The beam from the laser diode (A) is reflected off the beam splitter (B) and focused thru the objective lens (C). This beam reads the musical information pits (D) on each disc and returns once again thru the lens and the beam splitter with the encoded music. This in turn is shot into the photo-detectors (E) and you receive clean, ear-pleasing music.

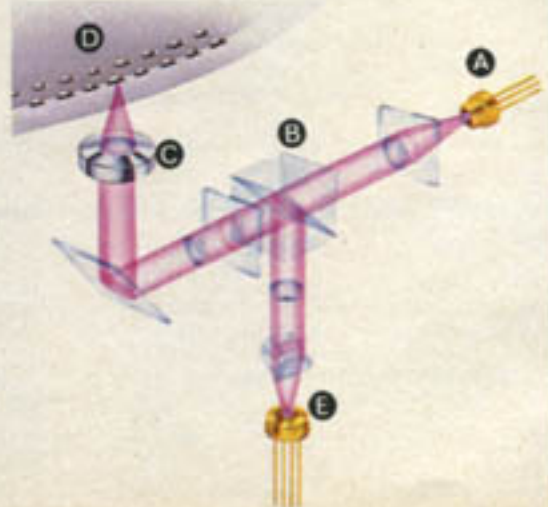

DISTINCTIVE ACCENTS



SAVE \$20 5-in. color TV

I 5-inch AC/DC color TV with 3-way operation. AC for home use, DC (uses 10 "D" batteries, not included, sold on pg. 380) or use it in your vehicle (car cord included). Full UHF/VHF tuning. Pushbutton Auto-Color for consistent colors. Has controls for auto, color, contrast, picture, brightness. 100% solid state chassis. Fold-down telescopic antenna. Carry handle serves as stand. Includes earphone jack. 5-in. (diag.) screen. Hi-impact plastic cabinet. UL listed. From Japan. 6½H x 11W x 13 in. D. See Wards Warranty in our Big Book or write for free copy, see page 322. Shown with simulated reception. Was 334.95, Fall Big Book, pg. 1029. See more TVs, pgs. 344-351.

63 T 12100 R—Ship. wt. 15 lbs. 314.88

J Personalize this quality handcrafted Tiffany style lamp by having your name inscribed on both sides. (Please note: 10 CHARACTERS MAXIMUM). Features a ¾-in. thick shade constructed of hand-cast pigmented polyester for durability and ease of cleaning. Includes 8-in. white opal globe and 18-in. chain. 11 in. high x 19-in. diameter. Ordering information.* See more light fixtures in our '81 Fall Big Book, pgs. 907-923.

S 84 T 63826 KE—Ship. wt. 18 lbs. 99.88

SWAG TIFFANY-STYLE FIXTURE: like above except swag hook, 18-in. cord, 15 ft. chain, an in-line switch, giving unlimited possibilities for location. 11 in. high x 19-in. diam. Ordering information*.

S 84 T 65160 KE—Ship. wt. 22 lbs. 99.88

*ORDER BEFORE NOV. 27th TO INSURE CHRISTMAS DELIVERY. Pay shipping from City of Industry, CA. Allow 20 days delivery. No C.O.D.'s.



SAVE \$50-\$90 on brass bed

K Give a future heirloom, a genuine brass bed.

Unique ceramic ball connectors with beautiful hand-painted floral motif and massive ball finials. Lacquer finish is electrostatically applied so it stays bright and shiny with just the buff of a cloth. Sets include headboard, footboard, steel frame—to assemble attach headboard, footboard to frame—hardware included, need only screwdriver and wrench. Headboard about 52 in. high, footboard about 41 in. high. More brass beds Big Fall Book, pages 1126, 1127—these prices cut from page 1127. To buy the velvet bedspread, pg. 261.

ITEM	Catalog number	Wt. lbs.	Was	Now
39-in. headboard	66T72100R	20	249.99	199.97
54-in. headboard	66T72101R	24	279.99	229.97
60-in. headboard	66T72102R	26	319.99	269.97
76-in. headboard	66T72103R	30	369.99	299.97
39-in. set	66T72105R	61	489.99	399.97
54-in. set	66T72106R	69	559.99	469.97
60-in. set	66T72107R	86	599.99	549.97
76-in. set	66T72108R	101	699.99	619.97

AA The cozy bedrest shown on opposite page is ideal for reading or watching TV. Sturdy wide wale corduroy—86% cotton, 14% polyester. Shredded urethane foam fill. Jumbo cord welting, side pockets on arms, carrying handle on back. Spot clean only. About 26x22x17 in. high. 5 colors: 165 melon (shown), 177 brick red, 136 gold, 148 brown, 108 green. State color number.

L 71 T 8753—Ship. wt. 4 lbs. 9 oz. 14.88



3 ways to charge all of your Christmas gifts!

SOLID STATE

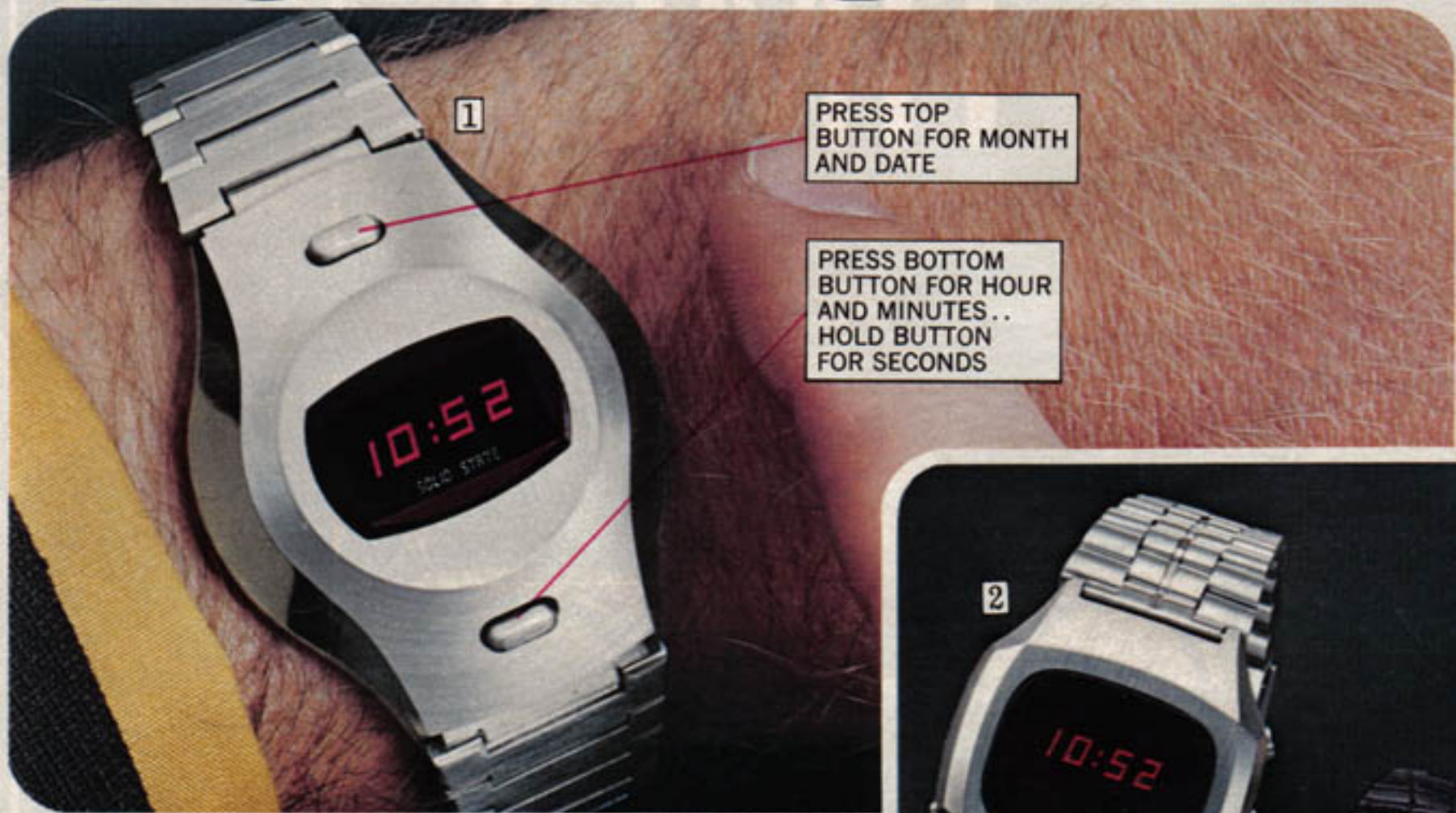

PRESS TOP
BUTTON FOR MONTH
AND DATE

PRESS BOTTOM
BUTTON FOR HOUR
AND MINUTES . .
HOLD BUTTON
FOR SECONDS

DIGITAL ELECTRONIC WATCHES FOR MEN

Our Finest Solid State Men's Watch

- Accuracy warranted to within three minutes a year
- Large, easy-to-read digits on a sleek dial
- Indicates month, date, hour, minutes, seconds . . A.M. or P.M.

1 The epitome of luxury and performance. Superb craftsmanship includes: ruby red dial that displays read-out in clear, unblinking digits when you press a button; tempered glass dial-cover that resists scratching, cracking; elegant stainless steel case and bracelet with fold-over buckle. Solid state technology means no moving parts . . no hands, no springs to wear out or run down. Never needs winding . . powered by 2 tiny, replaceable energy cells (incl.). Shock, water resistant. Shown larger than actual size. Japan. **FULL 3 YR. WARRANTY**—If, under normal circumstances, within 3 years from date of purchase, this watch fails to be accurate within 3 minutes a year due to defects in materials, workmanship, return it to any Sears Store in the U.S. and we'll repair it, free of charge. 4 C 4528—Shipping weight 10 ounces \$150.00

Elegant Watches display hour, minutes, seconds, date of month

(2 and 3) Fine Quality Solid State Men's Watches have no moving parts to wear out . . no hands, no springs to run down. And they never need winding . . they're powered by a tiny, replaceable energy cell (incl.). Shock, water resistant. Shown abt. actual size.

2 Touch-control Watch presents a ruby red face to the world until you press a button . . then you have a glowing digital display. Press top button for hour and minutes, bottom button for date; press both for seconds. Rich-looking stainless steel case, bracelet . . fold-over buckle. Scratch resistant crystal. Warranted* . . see below. 4 C 4532—Shipping weight 10 oz. \$89.95

3 Constant Read-out Watch continuously displays hour and minutes on time screen. Press top button once for seconds . . twice for date. Press bottom button for night reading. Yellow gold-color base metal case has stainless steel back. Gold-color dial. Leather-look brown Corfam® poromeric strap. Warranted* . . see below. 4 C 4531—Shipping weight 10 oz. \$89.95

Amazing Low Price for a Solid State Watch

4 Touch-control Watch. Press button for exact hour, minute display . . accurate to within 1 min. a year. Powered by a tiny, replaceable energy cell (incl.). Rhodium-plated base metal case has stainless steel back. Ruby red dial. Stainless steel mesh bracelet, fold-over buckle. Shock, water resistant. Shown abt. actual size. 4 C 4503—Shipping weight 10 ounces **\$49.99**

***FULL 1 YEAR WARRANTY.** If, under normal circumstances, within 1 year from date of purchase, either of these watches fails to be accurate within 3 minutes a year due to defects in material or workmanship, return it to any Sears Store throughout the United States. For item 2, we will repair it free of charge. For item 3 we will refund your money, repair it or replace it, free of charge.

Note for both pages: Shock resistant watches are designed to withstand a 3-ft. drop on a hard-wood floor without significantly affecting accuracy; water resistant watches are designed to withstand water pressure of 35 lbs. per square inch (in addition to normal atmospheric pressure) as long as crystal, crown and back remain intact.





A Home
Arcade
That's Always
Open for
Fun!

1
U.F.O.
Electronic
Pinball
99⁹⁹



Each has
multiple track
scoring

2
Cycle
Speedway
Pinball
74⁹⁹



3
Junior-Size
Pool Table
full-size fun!
79⁹⁵
60x30 in. wide



4
Add table tennis
to your hobbies
89⁹⁹

5
45-In.
Pool Table
29⁹⁹

Power Jet Hockey—make your
"slap shots" on a cushion of air—
as tough and fast as real hockey!



6
49⁹⁹
54x23 in. wide



7
69⁹⁹
54x27
in. wide

NHL Hockey
49⁹⁹
50x25½
in. wide

8



Pivot Pool
19⁴⁹
19x32½ in. long

9





35⁹⁷

Until Dec. 1 only

PLAYSKOOL

Electronic matching game



At Wards only!
Set of 15 extra
Genie cards

9⁹⁹
set

Alphie, the
electronic robot



Major Morgan™
The Electronic Organ



PLAYSKOOL

A Genie challenges you at math, spelling and music—makes learning exciting!
FEATURES: Answer correctly, Genie plays a song. If you're wrong, he razzes you. Sing along to 8 songs. 14 two-sided cards incl. Built-in handle. Uses one 9V battery (not incl.); alkaline recommended, order pg. 380. 10 1/2 x 2 1/2 x 10 1/4 in. Wt. 2 lbs. **AGES:** 3 to 8. 48 TF 15232 Until Dec. 1, **35.97** 48 T 15232 After Dec. 1, **37.97**
15 EXTRA GENIE CARDS. Math, spelling. 48 T 15236—At Wards only. Wt. 3 oz. **9.99**
SAVE \$1 when you buy both (A) and extra cards. Ship. wt. 2 lbs. 3 oz. 48 TF 15237 Until Dec. 1, **44.96** 48 T 15237 After Dec. 1, **46.96**

E Alphie, the play-and-learn robot.
FEATURES: He's programmed for quiz games, nursery tunes, board games. 4 two-sided program cards, gameboard, playing pcs. Order 9V battery (not incl.), pg. 380. 9 1/4 x 10 1/2 x 4 1/4 in. 48T15215—**AGES:** 3 to 8 Wt. 3 lbs. **24.88**

SAVE \$10 buy (G) with
Ray-O-Vac batteries, see pg. 484



B Magic Touch™ teaches a child to identify people, animals, places, shapes.
FEATURES: Touch the question, and put the "Magic Touch" on the answer. If correct, wand lights up and buzzes. Uses one 9V battery (not incl.); order on pg. 380. Incl. 9 two-sided cards, 200 activities. 48 T 15392—**AGES:** 4 to 8. Wt. 1 lb. **10.49**

C Major Morgan™ the Electronic Organ.
FEATURES: Insert song card, and play the 16-note keyboard following colors or symbols. Incl. 5 two-sided song cards; 10 songs. Order 9V battery (not incl.). 48T15250—**AGES:** 3 to 9. Wt. 1 lb. 1 oz. **15.33**

D Extra Major Morgan music cards for (C).
INCLUDES: 15 cards; 30 songs. 48 T 40601—Vinyl case. Wt. 2 oz. **6.99**

F Additional activity sets for (E).
INCL: 3 program cards, gameboard, playing pcs. per set. *State set no.:* 01 Numbers and Counting, 02 Add and Subtract, 03 Word Recognition. L48 T 40600—Wt. 3 oz. . . ea. set **3.99**

G Electronic Learning Machine™ teaches math, spelling, music.
FEATURES: Enter your answer; lights and sounds tell you if you're correct. 32 two-sided activity cards, 2 keyboard overlays, card storage caddy. Order 4 "C" batts. (not incl.), pg. 483; for rebate, pg. 484. **AGES:** 4-9. Wt. 2 lbs. 8 oz. 48 TF 15333 Until Dec. 1, **39.99** 48 T 15333 After Dec. 1, **42.99**

H Extra activity card sets for (G).
INCL: 36 two-sided cards per set, 200 activities—math, spelling, science, music. Choose cartoon characters—sets 03 (pre-school), 04 and 05 (grade 1); or Super Heroes—sets 06 and 07 (grade 2), 08 (grades 3, 4). Wt. 1 lb. L48 T 40915—*State set no.* ea. set **9.99**



COLECO

430 ALL2



Help Mickey catch all the eggs before they hit the ground and crack!

\$20



1

Disney Nintendo hand-held games, new and found only in Sears Land!



2

1 Hurry Mickey, catch those eggs! Test your skills at eye/hand coordination with Mickey and Minnie Mouse by seeing how many eggs you can catch before missing three in a row. The hens slowly lay their eggs in the beginning, but just when you think you've everything under control, the eggs start coming faster and faster. To complicate things even more, there are four different hens laying eggs! Musical chimes sound after the third miss. Keeps track of two different players' scores and stores highest score. Digital clock really keeps time. Plastic. Battery included. Warranted.* For ages 3 years and up. 49 N 63005—Wt. 4 oz... \$20.00

2 Mickey and Donald have joined the circus! How good are you at helping Mickey perform his baton acrobatics while balancing on a ball? Simply move Mickey left and right to catch the batons, but beware of the flaming torches... if he catches these he'll soon be finished! You get a point for each baton caught and tossed back up. Two skill levels, will score a maximum of 999 points. For 1 player. Liquid crystal screen, plastic case. Battery included. Warranted.* For ages 3 years and up. 49 N 63006—Wt. 7 oz... \$30.00

3 Can you score the most points? Test yourself against your friends or improve upon your own personal record with this Disney World Bagatelle game. Shoot the balls into the Disney World target worth the most points and you'll win. Spring-loaded activator. Includes 4 white balls and 1 black ball for bonus points. Steel and plastic. For ages 3 years and up. 49 N 63015—Wt. 12 oz... \$8.00

4 Who will get to Pooh's house first? Will it be you? Play this colorful 3-dimensional race through the world of Winnie the Pooh to find a winner. Children will encounter the Owl's house, Eeyore's gloomy place and Kanga's house en route to Pooh's house at Pooh Corner. Board game for 2 to 4 players. Ages 3 years and up. 49 N 61018—Wt. 1 lb. 6 oz... \$10.00

*Warranted by manufacturer. Write for free copy, see page 304.



3



4



5

5 A game of skill, and a little luck, as players toss beanbags at the giant Tic-Tac-Toss board. Who will be the first to get three in a row? Will it be Winnie the Pooh or Piglet? When you toss your beanbag, flip over the correct characters to win. Play individually or in teams, fun for the whole family. For 2 players or 2 teams. Plastic and fabric. 14 1/2 x 20 x 7 in. high. Ages 3 years and up. 49 N 63035—Wt. 1 lb. 4 oz... \$10.00

Sears Land is a toy store that really cares about YOU... see page 344

Save this catalog... order most toys thru August 31, 1989!

You can order any item on pages 308 thru 493, now thru 8/31/89... unless otherwise stated



A Subbuteo® Table Soccer... world's most popular soccer game played in over 30 countries.

INCLUDES: 22 detailed players, 2 goals with netting, 2 balls, 4 corner flags, marked cloth playing surface and a table-size fold-out board.

48 T 14831—AGES: 5 and up. Ship. wt. 2 lbs. 11 oz. 24.99

B Tin Can Alley®... world's best known electronic target-shooting game.

FEATURES: Aim and cock rifle—pull the trigger and a quick flash of light shoots out toward the cans. Shoot from up to 25 ft. away. If your aim is right, tin can flies off the fence! Uses one 9-volt and 3 "D" batteries, not included; order on page 380.

48 T 14030—AGES: 9 and up. Ship. wt. 5 lbs. 14 oz. 39.99

C The Champ™ Pool Table.*

FEATURES: Traditional billiard green surface, two cues, 15 balls, chalk and triangle. Live-action cushions and single-end ball return. Sturdy construction with steel legs and woodgrain panels. 45x22x26 inches.

48 T 14664 M—AGES: 8 and up. Ship. wt. 20 lbs. 29.88

D Atomic Arcade™ brings the thrill and action of pinball right into your home.

FEATURES: Ball movement sets off electronic bells and automatic scoreboard. Uses five "D" batteries, not included; order on page 380.

48 T 14619—AGES: 6 and up. Ship. wt. 5 lbs. 12 oz. 29.67

E Here's a dart/pistol/rifle target set that will ease parents' minds!

FEATURES: Target guns and rifle shoot over 25 feet with airflow power. Darts are fired on a cushion of air. Exclusive Flex® darts are soft and flexible, molded in one piece with suction cup that sticks firmly to surfaces. Throw-darts will really stay put like ordinary darts when thrown at target. Rifle and pistols will not house or fire anything but Flex darts.

INCLUDES: 13-in. and 9-in. bullseye targets, 10 Flex gun darts, 6 Flex throw darts, 2 airflow power target guns, one 24-in. airflow power rifle.

48 T 14719—AGES: 5 and up. Ship. wt. 2 lbs. 2 oz. 9.99

F Power Jet™ Hockey—fast moving air hockey action!

FEATURES: Streams of air blown from the powerful motor keep the puck gliding across the smooth surface. Sturdy plastic goals catch the puck and built-in scorekeepers record all points scored. Includes two controllers and two pucks. Sturdy construction with steel support legs. 54x22 in. UL listed.

48 T 14623 M—6-ft. cord. CSA app'd. AGES: 8 up. Wt. 37 lbs. 59.88

G Crestwood™ Pool table.*

FEATURES: Traditional billiard green felt surface, 2 wood 36-in. cues, 15 balls, chalk, bridge and triangle. Live action cushions and ball return. Sturdy construction with brown plastic legs with levelers, aluminum corners and top channel. Walnut-grained cabinet with stringers, full leg panels. 60x32 inches.

48 T 14721 R—AGES: 8 and up. Ship. wt. 68 lbs. 84.88

H Table tennis conversion top converts air hockey (F) and pool table (G) into table tennis games.

FEATURES: Full-size top. Net, ball and two paddles included.

48 T 14722 M—AGES: 8 and up. Ship. wt. 11 lbs. 18.99

I Electronic pinball featuring dramatic graphics and plenty of fun!

FEATURES: Electronic lights, rebound bumpers, kickout independent flippers. Digital scoring for 1-4 players, light-up bonus mode. Free ball feature. "Game over" light, tilt control. Sturdy construction with woodgrain cabinet and leg panels. Steel legs with braces. UL listed.

48 T 14714 M—AC transformer incl. AGES: 8 and up. Wt. 45 lbs. 169.99

J Carrom Set—play over 100 different games on this versatile game board.

FEATURES: 26x26-in. square game board, net pockets. Includes play rings, spin tops, cues, dice, rules for hours and hours of playing fun.

48 T 14862 M—AGES: 7 and up. Ship. wt. 7 lbs. 12.99

REVOLVING STAND for Carrom Board (J) above.

48 T 14860—Ship. wt. 2 lbs. 4.99

SAVE \$2 when you buy both Carrom set (J) and revolving stand above.

48 T 14875 M—Ship. wt. 9 lbs. separately would be 17.98; combo 15.98

K Folding Soccer takes fast and furious action to score and win!

FEATURES: Plan your strategy, battle it out and kick to win. You and your opponent control teams with telescoping rods that let players kick and move from side to side. Sturdy hardwood case folds for easy storage. 2 balls. 30x16 in. Made in Brazil.

48 T 14682—AGES: 8 and up. Ship. wt. 7 lbs. 19.99

L NHL Tournament Hockey... the rod hockey table you've wanted!

FEATURES: Two 3-D teams in official NHL uniforms. Smooth gliding control rods. Behind-the-goal action. Overhead score tower with automatic puck dropper. Plastic netted goals. Remote action puck ejector. Built-in scorekeepers. Woodgrained cabinet, full leg panels. Sturdy steel legs with braces. Molded plastic ends, clear rink shields. Overall 23x38 in.

48 T 14710 M—AGES: 8 and up. Ship. wt. 18 lbs. 49.88

M Official NFL Superbowl Electric Football with total team control.

FEATURES: You're the coach—win the superbowl! Players are in authentically reproduced uniforms. Player I.D. numbers included; 5 realistic poses. Steel game board (16x32 in.). Adjustable scoreboard. Automatic timing; speed control. UL listed. Safety plug with 5-ft. cord, heavy-duty switch.

48 T 14552—AGES: 8 and up. Ship. wt. 8 lbs. 4 oz. 26.66

N Now all your favorite teams can be in the Superbowl! All teams of the

NFL authentically reproduced in their official uniforms, available by Division. Figures attach to the total control base, not included. Be sure and state code number for teams wanted.

L 48 T 14551—AFC Central Division, 4 teams. Code: 01. Wt. 6 oz. 10.88

L 48 T 14551—NFC Western Division, 4 teams. Code: 02. Wt. 6 oz. 10.88

L 48 T 14551—AFC Eastern Division, 5 teams. Code: 03. Wt. 7 oz. 12.88

L 48 T 14551—AFC Western Division, 5 teams. Code: 04. Wt. 7 oz. 12.88

L 48 T 14551—NFC Eastern Division, 5 teams. Code: 05. Wt. 7 oz. 12.88

L 48 T 14551—NFC Central Division, 5 teams. Code: 06. Wt. 7 oz. 12.88

*When measuring for table, allow 3-feet playing area all around.



"Hey, Billy! The coast is clear! Meet me at the secret fort!"



\$19.99



1 Transmit messages in secret code! Deluxe 6-transistor Commando walkie-talkie set features Morse code buttons and chart so just the two of you will know the plan. Two hand-held units have flexible antennas, large, easy-to-use push-to-talk buttons, and on/off volume controls. Plastic housings. Operate on 49.860 MHz frequency. Req. two 9-volt batteries, sold on p. 406. Ages 6 years and up. Imported. 49 N 66289—Wt. 1 lb 12 oz . . . Set \$19.99

2 Sears Land—you're talking fun! Space Scout 4-transistor walkie-talkies have Morse code button and chart for sending secret messages. Flexible antennas for extra safety. Large push-to-talk buttons. Plastic housings. Set of two operate on 49.860 MHz frequency. Requires two 9-volt batteries, sold on p. 406. For ages 5 years and up. Was \$14.99 in our 1988 Toy Specialog. Imported. 49 N 66063—Wt. 13 oz . . . Set \$11.99

3 Fisher-Price® Sky Talkers™ are built tough. 4-transistor walkie-talkie set features Morse code button and symbols on front. Flexible antenna and hook for belt. On/off switch and volume control dial are recessed to help prevent damage. Made of durable plastic and metal. Set of two operate on 49.860 MHz frequency. Uses two 9-volt batteries, sold on p. 406. Warranted by Fisher-Price, write for free copy, see p. 304. For ages 5 years and up. 49 N 66174—Wt. 1 lb . . . Set \$29.99

4 You can't get a busy signal on the Intercom Phone. Two modern push-button phones are great for private conversations. Connected by 6 ft. of cord. On/off switch. Plastic housing. Req. two 9-volt batteries, sold on p. 406. For ages 3 years and up. Imported. 49 N 66245—Wt. 1 lb. 4 oz . . . Set \$9.99

5 "Take me to your leader." The Star Tran voice-activated helmet really amplifies your voice . . . it can even make you sound like a robot! Flashing light is synchronized with your voice. Microphone is molded in 8½x8x8-in. high plastic helmet. 3-mode switch for special effects. Flip-up visor. Requires one 9-volt battery, sold on p. 406. For ages 8 years and up. Imported. 49 N 66168—Wt. 1 lb. 10 oz . . . \$14.99

6 Light, sound and fun . . . all in one! All-purpose radio flashlight features an AM/FM radio with 3-inch dynamic speaker for weather reports or your favorite music station. Flashlight has a giant lens to cast a long-distance beam. Electronic siren for use in emergencies. LED power indicator light. Nylon carry strap and telescopic antenna. Plastic housing. Requires 3 "C" batteries, sold on p. 406. Imported. 49 N 66277—Wt. 1 lb. 12 oz . . . \$19.99

7 thru 9 Great Sony sound . . . just for kids! My First Sony™ electronics feature colorful designs, sturdy plastic construction, rubber protective accents, kid-sized buttons, and of course, the quality you expect from Sony. For ages 4 years and up. Imported.

7 Any child can carry a tune with Sony's Radio Cassette-Corder with sturdy handle. One-button recording through a built-in microphone, fast forward, rewind, and stop/eject buttons and slide-bar AM/FM tuning. Includes optional AC adaptor or uses 4 "C" batteries, sold on p. 406. 14x4x2½ in. high. 49 N 66529—Wt. 2 lbs. 6 oz . . . \$59.99

8 Sing along with your favorite songs. Cassette Player-Recorder includes handy microphone for putting your own voice to the music through the amplified speaker. Color-coded fast forward, rewind and stop/eject buttons. Carry handle. Uses 4 "C" batteries, sold on p. 406. 11½x6¾x3 in. high. 49 N 66523—Wt. 2 lbs. 12 oz . . . \$49.99

9 Stereo sound goes anywhere you do. Walkman Personal Stereo cassette player comes with color-coordinated headphones and a built-in volume limiter to prevent sound levels that might hurt kids' ears. Automatic shut-off at end of tape. Shoulder strap. Uses 2 "AA" batteries, sold on p. 406. 3½x5x1½ in. high. 49 N 66525—Wt. 14 oz . . . \$34.99



Any kid can be a whiz kid with these learning toys!

F TI's Speak & Read™ introduces 250 common words to your child through "See it/hear it" techniques that associate the written to the spoken word. Visual display. 3 skill levels. Includes book and earphone. Uses 4 "C" batteries*. Manufacturer's Warranty**. Ages: pre-school to 3rd grade. 48 G 51702—Ship. wt. 1 lb. 3 oz.44.99

G TI's Speak & Spell™ helps children learn basic spelling of over 150 words. Unit pronounces a word, child enters spelling. Praises correct answer or tells child to "try again". 4 skill levels. Visual display. Other exercises and games. Includes activity book and earphone. Uses 4 "C" batteries*. Manufacturer's Warranty**. 48 G 51701—Ages: grades 1 to 8. Ship. wt. 1 lb. 8 oz.44.99

H TI's Speak & Math™ tests your child's math skills with over 100,000 basic problems. Visual display. 3 skill levels. Praises correct answer or tells child to "try again". Includes book and earphone. Uses 4 "C" batteries*. Manufacturer's Warranty**. Ages: grades 1 to 6. 48 G 51703—Ship. wt. 1 lb. 8 oz.44.99

I Additional cartridges for Speak & Read. *State title number:* 01 Dog on a Log (for 1st graders) • 02 Who's Who at the Zoo (for 2nd graders) • 03 On the Tracks (for 1st graders) • 04 Seal That Flies (for 2nd graders) • 05 The Third Circle (for 2nd graders) • 06 Ghost in the House (for 3rd graders). 2 48 G 51707—Ship. wt. 5 oz.each 12.99

Additional cartridges for Speak & Spell. *State title number:* 01 Vowel Power (for grades 2-4) • 02 Basic Builder (for grades 2-4) • 03 Super Stumper (for grades 4-6) • 04 Super Stumper (for grades 6-8) • 05 Mighty Verbs (for grades 4-6) • 06 Vowel ventures (for grades 6-8). 2 48 G 51706—Ship. wt. 5 oz.each 12.99

J Little Professor™ uses 50,000 math problems to quiz kids. Your child chooses a function (+, -, X, +). Little Professor asks the questions—answer correctly and the next problem appears. Little Professor keeps the score! 4 skill levels. Uses 2 "AA" batteries*. Ages: 5 and up. 48 G 51705—Ship. wt. 8 oz.12.99

K TI's Touch & Tell™ combines touch, sight and sound to help children learn to recognize colors, shapes and common objects. Includes two double-sized picture panels, library for modules and panels. Uses 2 "D" batteries*. Manufacturer's Warranty**. Ages: 2 to 5 years. 48 G 51704—Ship. wt. 2 lbs. 2 oz.34.99

Additional Touch & Tell cartridges. *State title number:* 01 Alphabet Fun • 02 Animal Friends • 03 All About Me • 04 Number Fun • 05 Little Creatures. 2 48 G 51708—Ship. wt. 5 oz.each 12.99

L Alphie II from Playskool. Updated play-and-learn robot programmed for matching/guessing games, math and spelling exercises, music. Four, 2-sided activity cards included. Uses 4 "AA" batteries*. 9 1/4 x 5 1/4 x 10 3/4 in. high. 48 G 43649—Ages: 3 to 8. Ship. wt. 2 lbs. 6 oz.22.99

M Package of two activity sets for Alphie II. Sets include four activity cards, gameboard and playing pieces. 48 G 43650—Ship. wt. 13 oz.pkg. 8.99



J

Can you find the red car?



K



L



M



Save 33-40% on Armitrons thru Dec. 12



A-J Quartz sport and water-resistant watches for men (except J) never need winding. Water-resistant styles (A-E, H, I) are designed to withstand water pressure of 50 lbs. per sq. in. (equivalent to depth of 100 ft. or abt. 30 meters). This quality can be maintained as long as the crystal and back remain intact. Write for free copy of Mfr.'s Warranty, pg. 497.

(A) Water-resistant to abt. 100 ft., man's date quartz analog* of stainless steel. Sweep second hand plus fine features shown above.
45 GT 6725—Ship. wt. 12 oz. . . thru Dec. 12, 29.99

(B) Water-resistant to abt. 30 meters, combines analog* and digital faces for dual-time-zone capability. Gives time, date; 24-hr. alarm, 1/100-sec. chronograph.** Sweep second hand. Base metal bezel, stainless steel bracelet and back. 2-tone.
45 GT 6726—Ship. wt. 12 oz. . . thru Dec. 12, 39.99
You pay 49.99 (A), 59.99 (B) after Dec. 12, '84.

*Displays time by means of hr/min/sec hands.
**Watch equipped with additional mechanism to record fractional seconds and elapsed time intervals.

(C) Water-resistant to 100 ft., man's 2-tone, stainless steel analog.* Features 60-minute elapsed time bezel, date calendar and sweep second hand.
45 GT 6722—Ship. wt. 12 oz. . . thru Dec. 12, 39.99

(D) Water-resistant to 30 meters, man's calendar analog.* Black enameled base metal case, matching bracelet, black Roman numeral dial with sweep second hand.
45 GT 6727—Ship. wt. 12 oz. . . thru Dec. 12, 39.99
For (C) and (D) pay 59.99 each after Dec. 12, 1984.

(E) Water-resistant (30 meters) diver's analog.* Sweep hand and calendar; luminous markers/hands on black dial. Silvertone base metal bezel, stainless steel back, black plastic racing strap.
45 GT 6724—Ship. wt. 12 oz. . . thru Dec. 12, 24.99
You pay 39.99 after December 12, 1984.

(F) Men's Armitron combines an 8-digit, 4-function calculator and chronograph** alarm in this black acrylic digital. Gives time and date in dual time zones. From the Orient.
45 GT 792—Ship. wt. 12 oz. . . thru Dec. 12, 9.99
You pay 14.99 after December 12, 1984.

(G) Men's silvertone digital alarm. AM/PM alarm resets itself automatically. 6-digit display shows time and date; nightlight too. Base metal bezel; stainless steel back, bracelet. Orient.
45 GT 822—Ship. wt. 12 oz. . . thru Dec. 12, 9.99

(H) Water-resistant to 100 ft., his chrono-alarm digital shows time, date; 24-hr. alarm; 1/10-sec. chrono.** Metalized acrylic case; plastic band.
45 GT 6729—Ship. wt. 12 oz. . . thru Dec. 12, 9.99
For (G) pay 19.99, (H) 14.99, after Dec. 12, 1984.

(I) Water-resistant to 100 ft., his silvertone chrono-alarm w/long-life battery. Digital shows time, date; 24-hr. alarm; 1/10-sec. chronograph.** Base metal bezel; stainless steel back, bracelet.
45 GT 795—Orient. Wt. 12 oz. . . thru Dec. 12, 14.99
You pay 24.95 after December 12, 1984.

(J) Her chrono musical alarm (also repeat alarm) plays "Fleur de Lis". Gives regular or military time, date; 1/10-sec. chronograph.** Goldtone base metal bezel, bracelet; stainless steel back.
45 GT 1859—Ship. wt. 12 oz. . . thru Dec. 12, 17.99
You pay 29.95 after December 12, 1984.

ATARI 5200

Still setting new standards
in video arcade gaming

Save ^{a total of} \$80

Cut \$50 plus a \$30
rebate from Atari

The Console

All the strength of a home computer already built in . . . 16K RAM (random access memory) recreates all the frantic fun, plus generates more colors, sharper resolution plus bigger blasts, bangs and booms



Includes Super Breakout

The Controllers

Armchair control of starts and resets, even a midgame pause for careful pattern scrutiny



2

Trak-Ball Controller

Now your home system can be equipped with one of the fastest controllers in the arcades



3

New at Sears!

Command Control
Deluxe Joystick
The first adjustable joystick

It's called the SuperSystem, the limousine of home video games.

After you play it just once, you'll realize how differently it handles. Just imagine, the power of a home computer generating arcade-quality images, sounds and action. It's bound to have a smoother feel. Just touch your controller and your move is carried out almost instantly. Plus there are luxury features you'll not find elsewhere. Like the unique TV switch that changes to normal TV programming automatically when the console is turned off—no more reaching behind your set. Or leave the console on during your favorite TV show to retain the high scores. When you slide cartridges in or out of the receptacle, there's silence and the screen goes black—no irritating rasping or static. Storage is even made easier. Controllers fit neatly under cover at rear, cord wraps around base. Sleek-design controllers have twin fire buttons for left and right handed players.

Extra controllers expand the arcade feel.

Smooth-rolling table-top Trak-Ball (2) has a heavy base so it won't slip even during a real workout. Command Control Deluxe Joystick (3) actually lets you customize its feel by adjusting the swing and speed. Plus the system includes all the hits, like Joust, Centipede, Kangaroo, Galaxian that play like their coin-arcade prototypes. It's the SuperSystem. And it lives up to its name.

(1) The Console. Plastic 15x13¼-in. wide case. UL listed for 110-120-volts, 60Hz., AC. Warranted by Atari, see p. 323. Was \$199.99 in 1983 Spring Big Book, p. 687. \$119.99 after Atari rebate . . . see p. 545 for details.
49 C 75850C—Shipping weight 12 pounds Full Price \$149.99
49 C 75892—Replacement Controller. Shipping weight 8 oz. . . Each 24.99
49 C 75890—Power Adapter. Shipping weight 15 oz. 14.99
49 C 75891—Replacement Game Switch. Shipping weight 6 oz. . . . 29.99

(2) Trak-Ball Controller. Plastic 10½x10¼ inches wide. Warranted by Atari; to write for free copy, see page 323.
49 C 75893—Shipping weight 2 pounds 10 ounces \$89.99

(3) Deluxe Joystick. Attaches to regular controller for keypad functions. Skid-resistant grip pads on bottom. Plastic, 6 in. high, 4-in. square. Warranted by Wico; to write for free copy, see page 323.
49 C 75464—Shipping weight 15 ounces \$34.99

If the electronic game you order from this book happens to be on sale in a current book or has a manufacturer's rebate not listed here, we will honor the lower price or send you the rebate information—automatically.

Famous brand console TVs with state-of-the-art features



A

MAGNAVOX



B



17-function remote control for direct or scan tuning. Remote also lets you adjust/mute volume and control power

699.99 No money down
\$35 a month*

Magnavox stereo-ready TVs

A,B More than just console TVs... Magnavox combines remote control tuning with fine furniture cabinetry and stereo-ready sound for a super home video center. 17-function remote control lets you select any channel at random or you can scan up or down through your favorite channels. Remote also controls alternate channel, volume up/down, mute and review. 125-channel capacity, cable-ready.

Twin 3x5-inch speakers and 1.5-watt amplifiers. Stereo/SAP (separate audio program) connection for future stereo and second language broadcasts.

Automatic color system maintains consistent colors from channel to channel. Comb. filter separates colors for improved resolution. Light sensor. LED channel readout. 25-inch diag. screen. UL listed. Shown with simulated reception. Write for free copy of Mfr.'s Warranty, pg. 497.

(A) Traditional furniture styling in pecan finish with casters. About 30 in. high x 37 in. wide x 19 in. deep. 63 G 82535 R—Ship. wt. 142 lbs. 699.99

(B) Contemporary furniture styling in oak finish with swivel base. About 29 in. high x 34 in. wide x 18 in. D. 63 G 82525 R—Ship. wt. 141 lbs. 699.99

1,049.99 No money down,
\$53 a month*

Sony Trinitron has a 26-in. screen, Express Commander

C The ultimate in console TVs... Sony's 26-inch Trinitron. Express Commander provides direct access to all channels plus up/down scanning. Other functions include tint, color, brightness, volume, mute, tone Pay TV-ready switch and matrix sound for simulated stereo effect. Cable-ready. 107-channel capability in all.

Two 4-in. speakers. Stereo-ready circuitry with MPX output connector that provides a stereo audio signal to optional stereo decoder when stereo TV broadcasting becomes a reality.

Emmy award-winning Trinitron color system produces detailed lifelike color. LED channel readout. Hand-finished oak wood veneers and wood solids on all wood cabinet. Casters. About 31 in. high x 45 in. wide x 23 inches deep. 26-inch diagonal screen. UL listed. From Japan. Shown with simulated reception. Write for free copy of Manufacturer's Warranty, see pg. 497. 63 G 52614 R—Ship. wt. 241 lbs. 1,049.99

*Montgomery Ward Credit customers: This purchase may change your monthly payments depending on the highest balance on your account. Does not apply to AZ, NM and CR residents. See page 497.



C

Express commander remote control lets you control all functions!

Albert™ teaching toy
\$19.99



Professor Owl™
\$18.99



Cards store neatly in Professor Owl's wings

Give your child a boost in school and a friend as well with Albert™. He introduces children to basic skills, building a solid foundation for learning. A total of 120 lessons on 60 cards cover subjects like basic math, reading, shapes and more. Albert lights up and sounds his approval when your child answers the multiple choice questions correctly. His learning programs have already been used successfully by thousands of teachers. Requires one 9-v. battery, sold separately on page 404. Plastic. For ages 3 to 6 years.

49 N 17625—Shpg. wt. 1 lb. 13 oz. . . \$19.99

Whoooooo's the softest, wisest learning toy around? Professor Owl™, of course! This electronic playmate leads children in 16 exciting activities like "Match the Shapes", "Add the Dots" and more. Correct answers are rewarded with flashing lights and happy sounds. Includes 8 double-sided cards that wipe clean. Acrylic plush, surface washable. 15 in. high. Requires one 9-volt battery, sold separately on page 404.

For ages 3 years and up
49 N 17613—Shpg. wt. 2 lbs. 1 oz. . . \$18.99

"Smart" is an electronic learning toy that's so much fun to play with, children might not realize they're learning. "Smart" automatically selects the game and skill level of the card that's being played. He helps young children to match colors and shapes, while older children can test their spelling skills. He also plays songs to sing along with or will play back your child's own 15-note melody. Correct answers earn a musical salute while "Smart" nods his head. For incorrect answers, he shakes his head from side to side to advise your child to try again. Includes 4 two-sided Smartware cards. Order additional cards below. Requires 4 "AA" batteries, sold separately on p. 404. Shuts off automatically when he's left alone, to conserve power. Warranted by Combi™.

For ages 2 to 6 years.
49 N 17640—Shpg. wt. 2 lbs. 8 oz. . . \$24.99

4 and 5 Smartware sets expand the activities you can play on "Smart" . . . let the learning continue as children grow. Each set includes 4 double-sided cards. Shpg. wt. 6 oz.

4 Smart Thinking I; for ages 2 to 4 years.
49 N 17641 . . . Set \$4.99

5 Smart Thinking II; for ages 3 to 6 years.
49 N 17642 . . . Set \$4.99

Cut \$! Alphie II teaches children math, spelling, colors and problem solving. He provides music for a sing-along or a game of musical chairs. 4 two-sided activity cards provide loads of things to do. Additional activity sets sold below. Requires 4 "AA" batteries sold separately on p. 404. Warranted by Playskool™. Was \$24.99 in our 1986 Toys Specialog, p. 535.

For ages 3 to 8 years.
49 N 17631—Shpg. wt. 2 lbs. 8 oz. . . Now \$23.99

Package of 2 activity sets for Alphie II (not shown). Provide lessons for overlapping age levels. With 4 double-sided activity cards, game board and playing pieces. You get "Numbers, Letters & Shapes" for ages 3 to 5 years and "Get Ready to Read" for ages 4 to 6 years.

49 N 17632—Shpg. wt. 1 lb. . . Pkg. \$9.99

Talking Toby™ is the game-playing robot with lively facial expressions, a synthesized voice and 100-word vocabulary. He "reads" the game cards and offers encouragement as children play and learn about colors, sizes, numbers and animals. He blinks, rolls his eyes, moves his mouth and eyebrows on the LCD screen, in sync with his friendly voice. 29 colorful cards, game board and markers included. For 1 to 4 players. 12 in. high. Requires 4 "C" batteries, sold separately on page 404. Warranted by Coleco™. For ages 3 to 8 years.

49 N 17627—Shpg. wt. 2 lbs. 8 oz. . . \$54.99

*Write for free copy, see page 371



Get "Smart" . . .
the electronic learning toy
\$24.99



Alphie II
\$23.99



Talking Toby™
\$54.99

AS SEEN ON TV

PLAYSKOOL

ODYSSEY™ Electronic Game



99⁹⁹
complete with 12 screens

12 great electronic screen games
you play on your own TV!



Pass, check, score, defend!

Simulate the slap-shot action of a real hockey game and the precision service of a pro-tennis "ace" with the Odyssey™ Electronic Screen Game by Magnavox. Odyssey hooks up to any 18-25-in. (diagonal) color or black and white TV in a snap. Put a little spin on the "ball" with an "English" control as you and a challenger simulate exciting table tennis competition on your TV screen. To set up, attach the antenna-game switch to the antenna terminals of your TV. Connect the two Player Controls to the Master Control 15-ft. cord provided. To play an electronic game, turn on your TV to an unused station and insert a printed circuit Game Card into the battery-powered Master Control to activate 2 player lights and a ball. Master Control sets the speed; player control sets the action. Has plastic control units, two 5-ft. cords, six "C" cell batteries, instructions/rules booklet. Television set not included.

60 T 93542 MG—Ship. wt. 12 lbs. 99.99

9-volt AC adapter for Odyssey Game. Converts from battery to household 110 volt AC outlet.

60 T 93544—Ship. wt. 6 oz. 4.95

SAVE \$22 on Rifle when purchased with Odyssey™ Game



with Odyssey
789

Odyssey Shooting Gallery hooks up to your television screen. "Shoot" rifle at screen to stimulate electronic impulse "bullet" and moving target images.

Great fun for everyone! With rifle, target screens, hook-up cord, game cards.

60 T 93543 M—Wt. 3 lbs. 29.99

60 T 93543 MD—With Odyssey 7.89



The kick is good—you score!

74⁸⁸

Soccer table



A

A You can block, pass, kick and score like a real pro with our exciting table soccer game. Sturdy metal legs with safety rubber footpads prevent slipping. Good-looking wooden frame has hardboard top. Two 11-man teams are mounted on telescoping chrome rods with sure-grip handles. Game equipped with built-in scoring counters, automatic slide-ball return. 2 solid plastic balls included. Game shipped fully assembled for immediate play. 23³/₄x48x34¹/₂ in. high.

60 T 23818 R—Ship. wt. 48 lbs. 74.88

B Wards bumper pool table is built for people who want both entertainment and value. The 3/4-in. bed is covered with green billiard cloth made of 75% wool and 25% nylon. Woodgrain look panel legs. Four leg levelers provide a true roll for precision play. Two end ball returns. Play area is 28¹/₂x44¹/₂ in.; table is 33³/₄x50x31 in. 2 cues, balls, chalk, rules. Was 139.99 in Big Fall Catalog, page 862.

60 T 93520 R—Ship. wt. 123 lbs. 129.88

Rubber bumpers for lively action

CUT \$10 129⁸⁸

Bumper pool



B

ALL WARDS 297

Computer fun for little learners



(1) Quiz Wiz™. Poses questions on almost every subject, lets you punch in answer, then tells you if you're right or wrong by signaling with lights and sound effects. Play it alone or compete with others. Includes one cartridge and quiz book with multiple choice questions covering a variety of subjects. Plastic with vinyl case, 9½x5½x1½ in. high. Imported. 8 yrs. to adult. Uses one 9-v. battery, not included, order below. Order additional cartridges and quiz books below. Warranted by Coleco, write for free copy, see pg. 323.
49 C 17675—Shipping weight 1 lb. 6 oz.\$19.99

Additional Quiz Wiz Cartridges and Quiz Books. Each cartridge and book has 1001 questions with multiple choice answers.
49 C 17676—Fascinating Facts about Animals
49 C 17677—The Bible; Old and New Testament
49 C 17678—Words: Used, Misused and Confused
49 C 17679—Movies and TV
49 C 17681—Ripley's Believe it or Not!
49 C 17682—Guinness Book of World Records*
49 C 17683—Trivia
49 C 17684—Super Heroes**
49 C 17689—TV and Movies Super Trivia
49 C 17691—Major League Baseball
Shipping weight each 8 ouncesEach \$6.49
*©1979 Sterling Publishing Company. All rights reserved.
**Indicates trademark licensed by D.C. Comics, Inc.
Used under license.
†©1982 Ripley International Ltd.

(2) Computer Flash Cards. 108 cards provide an effective method for learning the basics of computer terminology and how to identify and learn the function of computer hardware. 3 different sets of cards.
6 years to adult.
49 C 17603—Shpg. wt. 1 lb. 4 oz.Set \$4.99

(3) Computron. An electronic mini-school that even allows you to program your own assignments if you wish. Display and sound effects encourage 1 or 2 children to respond by touching the keys to discover the right answers. Pre-programmed to teach math basics, spelling and to help develop word, object and musical note recognition.
Includes lesson booklet with 10 activities and more than 25,000 pre-programmed problems; also, an unlimited number of problems can be programmed. Plastic. 8x1x6 in. wide.
5 yrs. and up. Vinyl carry case. Uses 6 "AA" batteries, not incl. order below.
49 C 17703—Shpg. wt. 1 lb.\$29.99

Batteries for Electronic Learning Games
DieHard 9-volt Alkaline Battery
49 C 30949—Shpg. wt. 2 oz.Each \$2.39
DieHard "AA" Alkaline Battery, Pkg. of 2.
49 C 30909—Shpg. wt. 2 oz.Pkg. \$1.99

When you can't go home for Christmas, send Christmas home with Ship-A-Gift... see pg. 322

(4) Reader's Digest® Q&A Computer Question & Answer Game. Computer unit tests your knowledge on a wide range of subjects. Play it alone or with an opponent. Flashing lighted displays add luck and chance to final scores. Complete with 2 programmed games: "Brain Power" and "Word Power," each containing over 3,000 questions in 156 separate quizzes to test your wits in sports, entertainment, music, history and more. Additional games sold below. High impact plastic. 9½x7½x1½ in. For ages 8 yrs. to adult. Uses 9-volt battery, not included, order at left. Warranted by Selchow & Richter, write for free copy, page 323.
49 C 17661—Shpg. wt. 2 lbs. 2 oz.\$39.99

Additional Games programmed for use with Reader's Digest Q&A Computer Games. Each has over 1,200 questions arranged in 61 separate quizzes.
49C17662—The Bible 49C17663—Science Discoveries
49C17664—Word Power 49C17665—Jr. Word Power
49C17666—S.A.T. Math 49C17667—S.A.T. Reading
Shipping weight each 5 ouncesEach \$3.99

(5) Little Professor™ II. Tests math skills on 4 learning levels. The Little Professor™ II displays problems, then the child keys in his answer. After two tries, the correct answer is given. After a set of 10 problems, a total score is shown on the display. Plastic. 5¼x2¼x1 inches.
5 years and up. Uses one 9-v. battery, at left.
49 C 17604—Shpg. wt. 9 oz.\$9.99

It's you against the computer for the championship of the world!

The Kasparov Team Mate coaches and teaches you as you play

\$99⁹⁹

- ◆ 16K memory program offers 17 levels of play for beginners to experts
- ◆ "Tactical Alert" feature warns when you have missed the best move
- ◆ Stores unfinished game for up to a year



1 thru 4 Some of the best chess partners you've ever had! Our electronic chess games are endorsed by World Chess Champion Garry Kasparov as great companions for all levels of chess play; you pick the level to suit your skill. Easy-to-use sensor boards register your moves automatically. Computer allows you to take back your move any time during the course of the game. Save your unfinished games for later play. Batteries for (1 thru 3) are sold on p. 406. Warranted by Saitek; write for free copy, see p. 304.

1 It rates your playing strength as you improve. In fact, the Team Mate chess game gives you lots of tips and advice. State-of-the-art computer lets you pick your playing level, warns beginners when pieces are threatened and coaches you on 50 built-in tactical methods. Computer-controlled clock. High-impact polyurethane. Uses 3 "AA" batteries. For ages 7 years and up. 49 N 65027—Wt. 3 lbs. 1 oz. . . \$99.99

2 Turbo S-24K helps the serious chess enthusiast. 24K memory program lets you pick from 32 levels of play, ranging from casual and tournament play to analysis and problem-solving up to mate-in-20. Computer displays its move sequence so you can see its plans, and it even evaluates your position for you. Stores up to 30 full games for later play. Programmable library lets you store and recall up to 4,000 opening moves. LCD clock. High-impact polyurethane. Uses 4 "C" batteries. For ages 12 years and up. 49 N 65034—Wt. 3 lbs. 13 oz. . . \$149.99

3 Ideal for beginners and intermediate players, the Chess Partner lets you take back your move, verifies your position and shows you its next move to help you create strategy. Also helps problem-solve up to mate-in-3. Long-term memory stores interrupted games for up to a year. High-impact polyurethane. Uses 3 "AA" batteries. For ages 7 years and up. 49 N 65023—Wt. 1 lb. 12 oz. . . \$59.99

4 Take electronic chess on the road or anywhere else you need a good game. Computer adjusts to 8 levels of playing skill, suggests moves, allows take-back move, verifies your position and even problem-solves up to mate-in-3. Memory stores an unfinished game for up to one year. High-impact polyurethane. Uses 3 "AAA" batteries sold on page 406. For ages 7 years and up. 49 N 65491—Wt. 10 oz. . . \$29.99

5 This time, play bridge with a patient partner! Pro Bridge 100 offers 4 levels of play and plays on behalf of the other three players (your partner and 2 opponents). LCD screen shows your cards and dummy's, plus each round of bidding and play. Shuffles and deals random hands and records the score, tricks made and contract. Also lets you display all hands during bidding and rebid the deal. Includes playing cards, instruction booklet and quick reference card on bidding play. High-impact polyurethane. Uses one 9-volt battery sold on p. 406. Ages 7 years and up. 49 N 65036—Wt. 2 lbs. . . \$79.99

6 Electronic checkers for beginners or experts. You pick the skill level and the computer will do the rest. Take back moves at any time during the game. Computer knows all the rules of checkers and allows you to store unfinished games. High-impact polyurethane. Uses 3 "AA" batteries sold on page 406. For ages 7 years and up. 49 N 65017—Wt. 1 lb. 12 oz. . . \$49.99

The Turbo S-24K maps out strategies for the ultimate in chess enjoyment



2

Chess Partner gives you 8 levels of playing skill



3

Electronic Checkers gives you 8 levels of playing skills

- ◆ Automatically registers your move when you press down your checker
- ◆ Acts as referee for player vs. player games



4



5

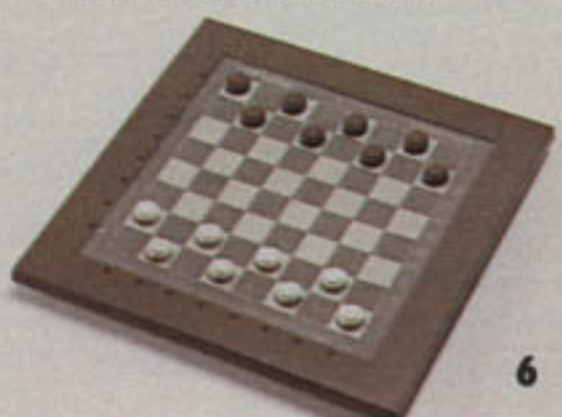

6



We'll deliver right to your home or office for just a little more than store pick-up for mailable orders



AS SEEN
ON TV

A challenge for adults, a learning experience for children—teaches eye, hand, sound and memory coordination

A 'Einstein' computerized memory game 24.99

Electronic games for the whole family!

B Compu-Bowl
14.99



C 'Merlin' plays six different games
29.99



D Road-Race game 14.99

E Digital Derby™
19.99



H 'Quiz Wiz™' 28.99



F M.V.P. Pinball
13.99



G Electro-mechanical Baseball
14.99



J 'Britannica' cartridges

K Quiz Wiz™ cartridges

PLAY THE SAME GAMES



New at Sears!

COLECO GEMINI™

Complete with 2 combination joystick/paddle controls plus BOTH game cartridges shown above

\$59.99

Choose your action from the world's largest cartridge library... plays any Atari® 2600 compatible cartridge. Plugs into any color or black and white TV. Easy-access novice/expert, game select and reset console switches. Warranted by Coleco, see page 323. 11x6¼-in. wide console, sleek, all-in-one controls. UL listed for 110-120-volt, 60-Hz. AC.
 49 C 75014—Shipping weight 5 pounds 4 ounces \$59.99
 Switch, for cable or standard antenna leads
 49 C 75475—Shipping weight 4 ounces..... \$5.99
 If the electronic game you order from this book happens to be on sale in a current book or has a manufacturer's rebate not listed here, we will honor the lower price or send you the rebate information—automatically.

New at Sears!



(15) Get winning advice from your on-screen friends! Gemini Sound I plugs directly into Coleco Gemini or Atari 2600 systems adding realistic voices and sounds to soon-to-be released Play and Learn cartridges. Includes Smurf's Voice cartridge with 3 coordinated story cassettes to teach kids colors and alphabet. 8x4¼ in. wide plastic case with volume, play, rewind and eject controls. Warranted by Coleco; write for free copy, see page 323.
 Shipping weight 14 oz.
 49 C 75015..... \$69.99

(16 and 17) Feel each gun burst with Power Arcade Controllers. Each plugs into any Atari 2600 compatible system for more realistic action than a mere joystick. Each includes a hair-raising game. Each requires 2 "D" batteries, not included, sold on page 595. Warranted by Milton Bradley, see p. 323.

(16) With the Flight Commander™ Machine Gun Controller you must be quick, sure and lucky to survive a Spitfire Attack cartridge.
 49 C 75683—Shpg. wt. 2 lbs. 10 oz. \$39.99

(17) With Cosmic Commander™ Cockpit Controller you thread thru a 3-D maze to destroy the enemy in Survival Run cartridge.
 49 C 75681—Shpg. wt. 2 lbs. 10 oz. \$39.99

(18 thru 23) For Atari 2600, Coleco Gemini, Sears Video Arcades. Warranted by mfrs.; see page 323.

(18) Joy-Sensor by Suncom, the joystick without a stick. Just rock your thumb over sensitive area.
 49 C 75408—Wt. 8 oz. .Ea. \$29.99

(19) Wico Track Ball allows 360° movement plus various on-screen speeds.
 49C75433—Wt. 1 lb. 10 oz. Ea. \$49.99

(20) Arcade Spheres convert standard Atari 2600 joysticks into ball top controls. Set of 2.
 49 C 75461—Wt. 3 oz. .Set \$3.99

(21) Wico Joystick has blade switches for incredible durability. 2 fire buttons; 1 on handle top, 1 on base.
 49C75430—Wt. 1 lb. 6 oz. Ea. \$29.99

(22) Slik Stik™ by Suncom plays like Atari 2600 joystick. 1 fire button.
 49 C 75405—Wt. 5 oz. .Ea. \$8.99

(23) Tac-2 Joystick by Suncom has ball and contact constr. for control you can see and feel. 2 fire buttons.
 49 C 75407—Wt. 10 oz. .Ea. \$16.99
 Lefty Joystick Adapter (not shown)
 49 C 75411—Wt. 4 oz. .Ea. \$5.99
 10 ft. Controller Extension Cable
 49 C 75460—Shpg. wt. 3 oz. \$4.99

See even more Atari 2600 Compatible Cartridges on the following 4 pages. . . .



Exciting action for any age

Pinball Table Games

Pinball Champ

- Teakwood-finish wood frame
- Sturdy steel legs
- 40x21x52 in. high

69⁹⁵

1

The Fonz Pinball Game

- Wood and plastic frame
- Sturdy steel legs
- 37x21x50 in. high

2 49⁹⁹

SAVE THIS CATALOG. Order anything on these two pages—at these low prices—until August 12, 1978



Feel the Thrills and Excitement of an Arcade in Your Own Home

1 & 2 **Fast Action Pinball.** Bells ring, lights flash, scores mount automatically. Electric games have all the features of real arcade pinball: independent flippers, scoring bumpers, multiple scoring tracks, and five steel balls with ball release. Free ball feature gives you an extra shot if your ball lands there. They even have tilt! Score up to 100,000 points automatically. Sturdy wood-composition construction with steel legs and leg braces. AC adapter included. UL listed, 110-120 volts, AC. Caution: electric toy—see note on page 491. Unassembled—instructions included. Warranted by manufacturer, see page 336. For ages 8 to adult. Not mailable; see page 338.

[1] **Pinball Champ.** All the features above, plus the amazing double-action rebound bonus bumper makes the game more exciting—makes your score soar! Teakwood-finish frame and leg panels.

X 925-4210 A—40x21x52 in. high, Shpg. wt. 50 lbs. 69.95

[2] **The Fonz[®] Pinball.** Decorated with the Fonz and his friends. White-finish wood frame with red plastic front and head panel.

X 925-4228 A—37x21x50 in. high, Shpg. wt. 50 lbs. 49.99

©1978 Paramount Pictures Corp.

3 & 4 **World Cup Soccer Table Games.** Maneuver with skill and speed and you'll score! 22 plastic players in bright, colored uniforms mounted on metal telescopic spring-action rods that glide smoothly for fast-action plays. Easy-grip plastic handles and plastic goals. Built-in scorekeepers to let you know who's ahead. Sturdy tubular steel legs with matching end panels. Not fully assembled—you attach legs. Includes rules and 2 balls. Not mailable; see page 338. For 2 or more players, ages 6 to adult.

[3] **Teakwood-Finish Wood Frame.** Aluminum bracing. Measures 45x35x32 in. high.

X 925-4236 A—Shipping weight 40 lbs. 69.95

[4] **Woodgrain-Finish Wood Frame.** Metal bracing. 38x27½x30 in. high.

X 925-4244 A—Shipping weight 16 lbs. 39.99



3 69⁹⁵

World Cup Soccer

- Teakwood-finish wood frame
- Aluminum bracing
- 40x23½ in. wide playing surface

World Cup Soccer

- Woodgrain-finish wood frame
- Metal bracing
- 33½x17½ in. wide playing surface



4 39⁹⁹

Soccer Table Games



11. The Rumi-K and Tripoley Crown game set . . . a winning combination! Rumi-K is based on the popular game of rummy but uses tiles. For 2 to 4 players. Tripoley Crown has all the thrills and chills of 3 great card games: hearts, poker and Michigan rummy. Includes chips, cards and deluxe layout. For ages 10 years and up.
49 C 61931—Shipping weight 2 lbs. 6 oz. . . Set **\$9.99**

12. Make the Monopoly® 1935 Commemorative Edition your keepsake! This special edition replicates the first Monopoly® games from 1935 with reissued original tokens and board label, wooden houses, "grand" hotels, ivory-hued dice and the specialty written Monopoly® story. Plus, it's housed in an elegant gift tin. For 2 to 10 players. For ages 8 years to adult.
49 C 61579—Shipping weight 2 lbs. 5 oz. . . **\$34.99**

13. Share in the celebration with the Monopoly® Deluxe Anniversary Edition. This edition is the only one to feature a special anniversary token—the famous Monopoly® train. Also includes 10 other tokens in a golden-color finish; wooden houses, hotels and the specially written Monopoly® story. For 2 to 10 players. For ages 8 years to adult.
49 C 61574—Shpg. wt. 3 lbs. 4 oz. . . **\$16.99**

14. Monopoly® carrying case takes the fun along. Carrying case holds one Monopoly® game, with room left over for other personal belongings. Ideal for parties, camping. 100% cotton with lining.
49 C 61534—Shpg. wt. 13 oz. . . **\$11.99**
Carrying case (14) with standard Monopoly® (sold below). Separate prices total \$20.98
49 C 61535—Shpg. wt. 3 lbs. 1 oz. . . Set **\$17.98**

Standard Edition of Monopoly® (not shown). The world's most popular board game features the special 50th anniversary logo on the cover and on the board label. For 2 to 8 players. For ages 8 years to adult.
49 C 61560—Shpg. wt. 2 lbs. 6 oz. . . **\$8.99**

15. Advance to Boardwalk and go places! Advance to Boardwalk is an extension of Monopoly® using the basic gameplay of building hotels. However, a cribbage board is used as a scorekeeper. For 2 to 4 players. For ages 8 years to adult.
49 C 61558—Shpg. wt. 2 lbs. 1 oz. . . **\$9.49**

16. Take the Computa-chess challenge! Hanimex's Computa-chess is a full sized portable chess game featuring 8 selectable skill levels of play. Moves are indicated by a tone, which can be turned off if desired. Also includes memory-save feature and a handy storage compartment for pieces. Requires 4 "AA" batteries, sold separately on page 459. Warranted by manufacturer.* Imported. For ages 8 years to adult.
49 C 65602—Shpg. wt. 4 lbs. . . **\$39.99**

17. Fidelity's Chess Classic offers 8 levels of skill. This portable game offers a sensory surface that automatically records your moves and illuminates countermoves. Convenient storage compartment for pieces. Magnetic playing surface and pieces. Requires 4 "C" batteries, sold separately on page 459. Warranted by manufacturer.* For ages 7 years to adult.
49 C 65631—Shpg. wt. 3 lbs. . . **\$69.99**

18. Fidelity's Excellence offers 12 levels of skill, plus a special "easy mode" for beginners. Sensory surface automatically records moves and illuminates countermoves. . . even thinks on opponent's time for fast countermoves. Estimated over 2,000 U.S.C.F. rating points. Magnetic surface and pieces, storage compartment for pieces. Requires 4 "C" batteries, sold separately on page 459. Warranted by manufacturer.* For age 7 years to adult.
49 C 65633—Shpg. wt. 3 lbs. . . **\$99.99**

19. Get a mental workout with Computachess from Hanimex. This portable chess game has 8 selectable skill levels to help you learn chess or improve your game. Includes carrying case. Requires one 9-volt battery, sold separately on p. 459. Warranted by manufacturer.* Imported. For ages 8 years to adult.
49 C 65601—Shipping weight 2 lbs. . . **\$29.99**
*Write for free copy, see page 335.

When you can't get home for Christmas, send Christmas home with Ship-A-Gift . . . see page 338



Sears salutes Monopoly's® 50th anniversary!

Save \$3 when you buy carrying case (14) and standard Monopoly® (not shown)



16



17



19

18

16 Voyager™ sends you on a learning adventure!

This educational product relies on interactive voice recognition. Headset asks questions and responds to "yes" or "no" and "true" or "false" answers with encouragement, sound effects and more challenging questions. Comes complete with a "Journey to the Prehistoric World™" cartridge which includes 2 games and an activity guide. One-speaker design allows child to hear outside sounds. Volume control limiter helps protect hearing. Automatic shut-off. Requires 4 "AAA" batteries, sold separately on p. 406. Warranted*. For ages 5 to 9 years.

49 N 17950—Wt. 2 lbs. . . \$59.99

Additional cartridges for Voyager™.

- 49 N 17953—Journey into Space
 - 49 N 17952—Journey to Birds and Reptiles
 - 49 N 17951—Journey to Exotic Animals
- Wt. ea. 14 oz. . . Each \$19.99

*Warranted by Texas Instruments, write for free copy, see p. 304.

17 Touch and Discover™ develops skills in language, vocabulary, numbers and more with the help of Disney friends. Responds to child's touch, asking questions and scoring. 8 built-in activities, automatic shut-off. Requires 4 "AA" batteries, sold separately on p. 406. Warranted*.

For ages 2 to 5 years.
49 N 17614—Wt. 2 lbs. 11 oz. . . \$59.99

Expansion cartridges for (17) (not shown). Each has 16 additional activities. Wt. each 11 oz.
49 N 17615—New Discoveries™ . . . \$21.99
49 N 17618—Advanced Discoveries™ . . . \$21.99

18 Touch & Tell™ has a touch-sensitive surface that works with interchangeable picture panels to teach letters, numbers and more. Electronic voice asks questions. Requires 2 "D" batteries, sold separately on p. 406. Warranted*.

For ages 2 to 5 years.
49 N 17801—Wt. 2 lbs. 9 oz. . . \$34.99

Additional modules for (18) (not incl.) Overlays incl.

Description	Catalog No.
"Alphabet Fun" identifies letters	49 N 17849
"Number Fun" teaches number values	49 N 17851
"Animal Friends" teaches animal names and sounds. . .	49 N 17853
"All About Me" promotes self-awareness	49 N 17855
"The World of Transportation"	49 N 17857
"Little Creatures" teaches nature life	49 N 17859

Wt. each 5 oz. . . Each \$14.99

19 Ready . . . Set . . . Read™ develops pre-school reading skills. Voice guides child through book with 28 learning activities incl. Automatic shut-off. Req. 4 "AA" batteries, sold separately on p. 406. Warranted*. For ages 3 to 7 years.

49 N 17662—Wt. 2 lbs. 11 oz. . . \$79.99

Expansion packs for (19) (not incl.) Each incl. cartridge and 49 activities in 7 colorful books. Wt. each 6 oz.

- 49 N 17663—Learning Book I. . . Set \$21.99
- 49 N 17664—Learning Book II. . . Set \$21.99



17

Touch and Discover™ for early learning fun!



18

Touch & Tell™ helps teach letters and numbers



19

Ready...Set...Read™ develops pre-school reading skills



With Voyager™, you can go back to prehistoric times, travel through space, or go on a photo safari . . . your voice controls the action!



16





119.99-299.99

Monochrome or color, Zenith monitors are the affordable answer

A No money down, \$17 a month.* Zenith RGB/Composite 13-in. color video monitor. Designed to interface with most personal computers: Commodore 64, VIC-20, Apple II, III, Atari 800 and XL series and TI 99/4A (additional cables and adapter required, sold below). The ZVM 131 exhibits impressive graphics, clear copy and has an internal speaker for excellent sound reproduction. Screen display of 25 lines by 40 characters. Has "Green Screen Only" feature that eliminates all other colors for easy reading of text material. Easy-to-reach front access user controls for picture, black level, color level, tint, sharpness, audio volume and background noise. Mfr.'s Warranty.**

67 G 20401 LS—Ship. wt. 38 lbs. 299.99

B Zenith 12-inch monochrome monitor with green phosphor display. The ZVM 123 is compatible with most popular computers: Commodore 64, VIC-20, Apple II, III, Atari 800 and XL series, IBM PC, Compaq and TI 99/4A (additional cables and adapter required, sold below). Offers a large-capacity display—up to 25 lines by 80 characters. 40/80-column character switch allows it to be used with most computers. Conveniently located front exterior controls include power, black level, contrast, horizontal/vertical hold and vertical height. LED power indicator. Mfr.'s Warranty.**

67 G 20400 LS—Ship. wt. 14 lbs. 119.99

Audio adapter plug for sound capabilities.

62 G 00139—Ship. wt. 7 oz. 1.89

Computer to monitor cable for Commodore 64, Atari and TI. 62 G 3497—Ship. wt. 1 lb. 9.99

399.99 No money down \$20 a month*

Epson RX-80 F/T printer uses friction or tractor feed paper

C The Epson RX-80 F/T dot matrix printer prints up to 100 characters per second and features six user selectable graphics modes in six different densities. These enable you to mix and match text and graphics on the same line. Unlike many printers, you have the option of using standard fanfold paper, or snap out the removable tractor/bar and use roll or single sheets.

This all-purpose 80-column printer has standard 96-character ASCII set plus 11 international character sets, and 32 graphics characters. This is enhanced by the 128 different typestyles, including Pica, Elite, Underline and Italics. Bi-directional printing and logic seeking of the shortest line for additional speed. Additional interface required, see below. Manufacturer's Warranty.**

67 G 20500 LS—Ship. wt. 12 lbs. 399.99

Computer to printer interfaces. Ship. wt. 1 lb. 2 oz.

62 G 40114—IBM to Epson printer 44.99

62 G 40115—Apple to Epson printer 69.99

Commodore 64, SX64, VIC-20 to Epson printer.

62 G 40116 69.99



79.99

Save \$10 on KoalaPad™ Touch Tablet. Puts your Commodore 64 computer's controls at your fingertips

D Give your Commodore 64 computer the human touch. Draw, color, illustrate and enlarge with just your finger. No more lengthy commands, no more hours of typing—just touch and create charts, graphs or illustrations. The KoalaPad tablet gives you total cursor control and it needs no additional hardware to operate. It can even be used as a joystick with more speed and accuracy.

The KoalaPainter® program cartridge comes with each Touch Tablet. With the KoalaPainter

you can draw freehand, make a single dot or line, several continuous lines and color. You can also erase, select background colors or save and retrieve your pictures at a touch. And if you ever need help it's only a touch away. This exciting new concept has applications from business and education to personal entertainment. For Commodore 64. Cut from our 1984 "M" Bk., pg. 64. Manufacturer's Warranty.** Shipping weight 1 lb. 12 oz.

67 G 20300 LS. was 89.99; now 79.99



KoalaPainter



KoalaGrams



Spider Eater

Order your KoalaPad™ software here:

Title**	Description	Cat. no.	Wt.	Price
Paint-A-Rhyme™	Coloring book of 36 popular nursery rhymes. Children paint scenes, as well as learn the words and music.	62G40180	8 oz.	29.95
Programmers Tool Kit™	For programmers who want fast, ready-to-use tools for writing programs for the KoalaPad.	62G40181	8 oz.	39.95
KoalaGrams™	Colorful spelling game for grade levels 1, 2 or 3. Unscramble words and place them in order.	62G40182	8 oz.	39.95
Spider Eater™	Exciting educational game helps children to recognize and learn musical notes and tones.	62G40183	8 oz.	29.95

*Montgomery Ward Credit customers: This purchase may change your monthly payments depending on the highest balance on your account. Does not apply to AZ, NM and OR residents. See page 497.

**Write for a free copy of Manufacturer's Warranty, see page 497.



D



Dominoes

A Dominoes are packed in all wood, hand-antiqued treasure chest.
CONSTRUCTION: Gleaming, Catalin 2x1x $\frac{3}{8}$ in. double 6 dominoes. All wood chest is hand-antiqued; antique-look studs and clasp.
 53 T 2943—Ship. wt. 5 lbs. set 9.99

B Double nine . . . dominoes in stylish brown vinyl case. Domino size: 2x1x $\frac{1}{8}$ inches.
 53 T 6236—Ship. wt. 7 lbs. set 10.99

Save time at Christmas . . .
 Home Delivery's fast, easy. See page 322.

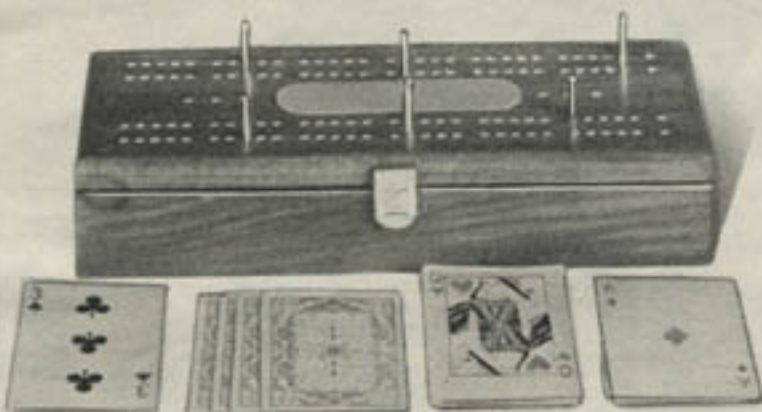

Cribbage

Here's an old time family favorite and it's actually two games in one! Three track cribbage in a unique design and dominoes.

FEATURES: Solid wood case with natural finish. Lift-up board top with clasp conceals storage compartment for cards and pegs that are included. Also included are a complete set of double 6 dominoes similar to (A) above.

53 T 2930—Ship. wt. 7 lbs. set 14.99

Backgammon and chess

E-H Backgammon—the game everyone's playing for fun and excitement.

INCLUDES: Case, board and playing pieces. Brown fabric playing board with stitched points. Coordinating full set of playing pieces, 2 vinyl dice cups, 2 pair dice, doubler and playing instructions. Case available in four styles. Carrying handle.

(E) Brown plaid attaché/vinyl trim. 15x11 in.
 53 T 6205—Ship. wt. 3 lbs. set 19.97

(F) Padded burgundy vinyl attaché. 15x11 in.
 53 T 6204—Ship. wt. 3 lbs. set 19.97

(G) Padded vinyl attaché/stripes. 15x10 in.
 53 T 6203—Ship. wt. 3 lbs. set 11.97

(H) Magnetic zipper case with carrying strap. Padded vinyl case. 10x7 in.
 53 T 6202—Ship. wt. 2 lbs. set 9.97

I Magnetic chess/checker set is an ideal gift for travelers; eliminates the worry of jostling the board.

CONSTRUCTION: Handsome plastic case with simulated wood finish. Closed. 11x15 $\frac{1}{2}$ in. case for pieces. Open. 11x11 in. board.

53 T 2864—Ship. wt. 2 lbs. set 7.49

J Carved wood chess set has genuine inlaid wood chess board and wood pieces.

INCLUDES: Attractive walnut and natural finish. Handy wood storage box. 13 $\frac{1}{2}$ x13 $\frac{1}{2}$ inches.

53 T 6291—Ship. wt. 5 lbs. set 19.97

K Contemporary design inlaid chess table is a handsome addition to game room, family room or den.

CONSTRUCTION: Good-looking walnut-finish table with inlaid wood playing surface. Rubber molding protects table edges. Table 20x20 in. 19 $\frac{1}{4}$ in. high. Large base keeps playing surface stable. Easy to assemble base, pedestal, table top.

53 T 2869—Ship. wt. 9 lbs. 22.99

CARVED WOOD CHESS PIECES (inset) are the perfect complement to any chess board, a welcome gift for chess enthusiasts. Staunton design; each piece is weighted and felted.

53 T 2871—Ship. wt. 1 lb. set 11.99

SAVE \$10 when you buy chess pieces above with table (K) above. Separately would be 34.98.

53 T 2874—Ship. wt. 10 lbs. coribo 24.97



Pachinko pinball

Pachinko pinball—direct from the arcades of Tokyo's glittering Ginza Pa-Chin-Kol it's the name of the game—also the sound of the steel balls hitting one another as they drop into the win pocket. The flip of the lever sends a steel ball racing through a fascinating maze. Hit the jackpot and a bell rings, you then win extra playing balls. 20 $\frac{1}{2}$ x9 $\frac{1}{2}$ x30 in. high.

CONSTRUCTION: Each game is an original—reconditioned, factory cleaned and inspected to insure hours of fun. Unfinished wood frame. Designs may vary from that shown. 300 steel balls and metal stand included. Made in Japan.

53 T 2790 A—Shipping weight 41 lbs. 39.99

REPLACEMENT METAL STAND for all similar Pachinko games.
 53 T 2789—Made in Japan. Ship. wt. 1 lb. 4.99

PKG. OF 200 EXTRA STEEL BALLS. Made in Japan.
 53 T 2791—Ship. wt. 3 lbs. 6.99

SAVE \$4 when you buy complete Pachinko outfit.

INCLUDES: Pachinko game, metal stand and package of 200 extra steel balls. Would be 46.98 if bought separately.

53 T 2799 A—Ship. wt. 44 lbs. outfit 42.97